

# AKM<sup>®</sup> Servo Motor

Three-Phase AC Permanent Magnet Servo Motor

## Selection Guide



Australian Distributor for Kollmorgen



hello@motion-werkz.com  
www.motion-werkz.com  
Call us: 0499 885 772

# KOLLMORGEN

A REGAL REXNORD BRAND

# Kollmorgen: Your Partner, In Motion.

Every solution comes from a real understanding of the challenges facing machine designers and users.

Innovators consistently rate Kollmorgen as one of their best motion systems manufacturing partners. Whether you are looking for classic servo motors, direct-drive servo motors, stepper motors, drives & amplifiers, gearing, actuation, or multi-axis motion controllers, Kollmorgen is one of the few companies in the world that actually designs and manufactures all of these products.

Our customers are leaders in many industries such as Aerospace & Defense, Printing, Packaging & Converting, Food & Beverage Processing, Medical Imaging, In Vitro Diagnostics & Laboratory Automation, Pharmaceutical Manufacturing, Material Forming and Cutting, Oil & Gas, and Robotics. Kollmorgen is also a leader in Warehouse Automation, including complete AGV systems, software, awareness and autonomy.

Our Automation Solutions can be found on Mars and in space, ships and submarines, O&G drilling and metrology, surgical robots and laser eye surgery, even inside artificial hearts. These are just a few applications that demand high-performance and high-quality while satisfying their specific needs.

Because motion matters, it's our focus: Motion can distinctly differentiate a specific machine and deliver a marketplace advantage by increasing its performance and dramatically improving Overall Equipment Effectiveness (OEE).

High-performance motion can make your customer's machine more reliable and energy-efficient, enhance accuracy and improve operator safety. Motion also represents endless possibilities for innovation.

We've always understood this potential, and thus have kept motion at our core and in our Vision, Mission & Values, relentlessly developing products that offer precise control of torque, velocity and position accuracy in machines that rely on complex motion.

**Removing the Barriers of Design, Sourcing, and Time**

At Kollmorgen, we know that OEM engineers can achieve a lot more when obstacles aren't in the way. So, we clear obstacles in three important ways:

**Integrating Standard and Custom Products**

The optimal solution is often not clear-cut. Our application expertise allows us to modify standard products or develop totally custom solutions across our whole product portfolio so that designs can take flight.

**Providing Motion Solutions, Not Just Components**

As companies reduce their supplier base and focus their engineering manpower on the product design, they need a total system supplier with a wide range of integrated solutions. Kollmorgen offers complete solutions as well as motion subsystems that combine programming software, engineering services and best-in-class motion components.

**Global Footprint**

With direct sales, engineering support, manufacturing facilities, and distributors spanning the Americas, Europe, the Middle East, and Asia, we're close to OEMs worldwide. Our proximity helps speed delivery and lend support where and when they're needed.

**Financial and Operational Stability**

Kollmorgen is part of Regal Rexnord. A key driver in the growth of all Regal Rexnord segments is the Regal Rexnord Business System, which relies on the principle of "kaizen" – or continuous improvement. Using world-class tools, cross-disciplinary teams of exceptional people evaluate processes and develop plans that result in superior performance.

**Kollmorgen: Your partner. In Motion.**

**Trademarks**

AKD is a registered trademark of Kollmorgen Corporation  
 AKM is a registered trademark of Kollmorgen Corporation  
 Cartridge DDR is a registered trademark of Kollmorgen Corporation  
 EnDat is a registered trademark of Dr. Johannes Heidenhain GmbH  
 EtherCAT is a registered trademark and patented technology, licensed by Beckhoff Automation GmbH  
 Ethernet/IP is a registered trademark of ODVA, Inc.  
 Ethernet/IP Communication Stack: copyright (c) 2009, Rockwell Automation  
 sercos® is a registered trademark of sercos® International e.V.  
 HIPERFACE and HIPERFACE DSL are registered trademarks of Max Stegmann GmbH  
 PROFINET is a registered trademark of PROFINET and PROFINET International (PI)  
 SIMATIC is a registered trademark of SIEMENS AG  
 SpeedTec, ytec, itec and htec are registered trademarks of TE Connectivity Ltd.  
 Windows is a registered trademark of Microsoft Corporation

**Table of Contents**

- ▶ **AKM® Servo Motor Family** **4**
- ▶ **AKM Model Nomenclature** **10**
- ▶ **AKM Servo Motor Quick Guide** **14**
- ▶ **AKM Servo Motor Specifications** **16**
  - Performance Data, Motor Parameters, Dimensional Drawings and Data
  - AKM1x Series Motor Specifications 22
  - AKM2x Series Motor Specifications 24
  - AKM3x Series Motor Specifications 26
  - AKM4x Series Motor Specifications 28
  - AKM5x Series Motor Specifications 32
  - AKM6x Series Motor Specifications 34
  - AKM7x Series Motor Specifications 38
  - AKM8x Series Motor Specifications 40
- ▶ **Brake Option** **55**
- ▶ **AKM Feedback Options** **56**
- ▶ **AKM Servo Motor Connector Options** **64**
- ▶ **AKM Servo Motor Connector Pinouts** **64**
- ▶ **AKM Technical Guide** **70**
  - I. L10 Bearing Fatigue 70
  - II. Shaft Loading 72
  - III. Teflon Shaft Seals 72
  - IV. Thermal Sensor Protective Devices 73
  - V. Delta Between Motor Winding and Thermal Dev. 74
  - VI. Motor Phasing Diagram 74
- ▶ **Kollmorgen Solutions** **75**
  - Automation and Motion Control 75
  - Self-Help Tools 75

# AKM<sup>®</sup> Servo Motor Family

Kollmorgen's AKM family of servo motors gives you unprecedented choice and flexibility from a wide range of standard products so you can select the best servo motor for your application.

With the broad range of AKM and AKM2G motors that support voltages up to 480 Vac, washdown, food grade, and the AKMH stainless steel hygienic motor for the toughest environments- Kollmorgen has a standard motor solution that can meet your needs right from the catalog.

Still need more? For your truly unique motion control applications, work with our engineering team to customize a solution for your machine design. Either way, standard product or customized, we can help you choose the motion control solution that meets your exact requirements.



## The Benefits of AKM® Servo Motors

---

### Best-in-Class Performance

- » Industry-leading motor power density
  - » Same size AKM/AKD system delivers up to 47% more shaft power
  - » Compensation for stiff and compliant transmissions and couplings
  - » Exceptionally low cogging
- 

### Flexibility to Find an Exact-fit Solution in a Standard Product

- » AKM offers 28 frame-stack combinations and 120 standard windings in a single motor line
  - » 4.8 million possible AKM part number combinations and growing
  - » Simplifies or eliminates mechanical modifications and engineering adaptation
  - » Available with single cable technology with digital feedback (Digital Resolver SFD3, SFD-M, or HIPERFACE® DSL)
  - » Washdown and Food Grade options for AKM
  - » Higher torque models up to 180 Nm of continuous torque
- 

### Ease-of-Use and Faster Commissioning

- » Plug-and-play motor recognition drive commissioning
  - » Reduce cycle time and sensor-and-wiring costs by eliminating traditional homing methods
  - » Reduction in set-up time for each servo system
-

# AKM<sup>®</sup> Servo Motor Family

## AKM Motors Offer Extremely High Torque Density and High Acceleration

The AKM high-performance motor series offers a wide range of mounting, connectivity, feedback and other options. These motors offer superb flexibility to meet application needs with:

- 8 frame sizes (40 to 260 mm)
- 28 frame-stack length combinations
- More than 120 standard windings



### Features

#### Torque

0.16 to 180 Nm continuous torque (1.4 to 1590 lb-in) in 28 frame/stack combinations. Specific torques are often available from multiple frame sizes to optimize mounting and inertia matching capabilities.

#### Speed

Speeds up to 8000 rpm meet high speed application requirements. Windings tailored to lower speeds are also available.

#### Voltage

AKM motors can be applied to all standard global voltages. Windings are specifically tailored to work with drives powered by 75 Vdc, 120, 240, 400 or 480 Vac.

#### Mounting

Multiple mounting standards are available to meet common European, North American, and Japanese standards.

#### Feedback

AKM motors include resolver, encoder (commutating), Sine-Absolute encoder or SFD (Smart Feedback Device) feedback options to meet specific application requirements.

#### Smoothness

Smooth performance results from low-cog, low-harmonic distortion magnetic designs.

#### Connectivity

Rotatable IP65 connectors, straight IP67 connectors or low cost IP20 Molex plugs are both available to provide flexibility. Single connectors/plugs (combined power and feedback) are also available to minimize motor and cable cost (SFD and DSL only).

#### Thermal

Windings are rated conservatively at 100°C rise over a 40°C ambient while using 155°C (class F) insulation materials. Motors meet applicable UL, CSA, and CE requirements and include thermistors.

#### Additional Options:

- » Holding Brakes
- » Shaft sealing options available
- » Feedback devices
- » Shaft and mounting variations
- » Custom windings
- » Connectivity

## Kollmorgen AKM Configurable Servo Motor Features



**KOLLMORGEN**  
**3Φ PM SERVOMOTOR**  
 MODEL: AKM42J-AND2CA00  
 CUST P/N  
 Ics 7.6 Arm  
 Tcs 3.2 Nm  
 Vs 320 VDC  
 Nrtd 6000 RPM  
 Prtd 1.27 kW  
 Rm 0.8 Ω (L-L) @ 25°C  
 SERIAL # 170820034  
 AMBIENT 40°C IP54  
 CLASS F  
 Assembled in USA -R03  
 www.Kollmorgen.com

**UL**  
 E61960  
 KM-180

**CE**  
 N60034-1  
 60034-5

**CE** **UL**  
 EN60034-1  
 EN60034-5  
 E61960  
 PS155-1

# AKM<sup>®</sup> Servo Motor Family

Offering a broad power range along with durability and economy



## AKM1

Flange: NEMA 17 / 40 mm  
Power: 0.08 - 0.30 kW  
Max Speed: 8000 RPM  
Stacks: 3



## AKM2

Flange: NEMA 23 / 58 mm  
Power: 0.10 - 0.94 kW  
Max Speed: 8000 RPM  
Stacks: 4

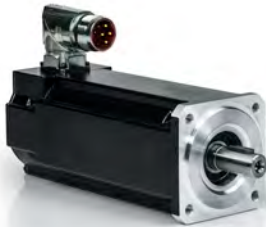

## AKM3

Flange: 70 mm  
Power: 0.09 - 1.31 kW  
Max Speed: 8000 RPM  
Stacks: 3



## AKM4

Flange: NEMA 34 / 84 mm  
Power: 0.21 - 1.73 kW  
Max Speed: 6000 RPM  
Stacks: 4



## AKM5

Flange: NEMA 42 / 108 mm  
Power: 0.56 - 3.87 kW  
Max Speed: 6000 RPM  
Stacks: 4



## AKM6

Flange: 138 mm  
Power: 1.17 - 6.24 kW  
Max Speed: 6000 RPM  
Stacks: 4

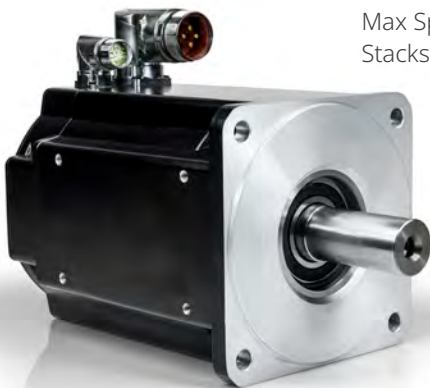

## AKM7

Flange: 188 mm  
Power: 3.97 - 8.58 kW  
Max Speed: 6000 RPM  
Stacks: 3

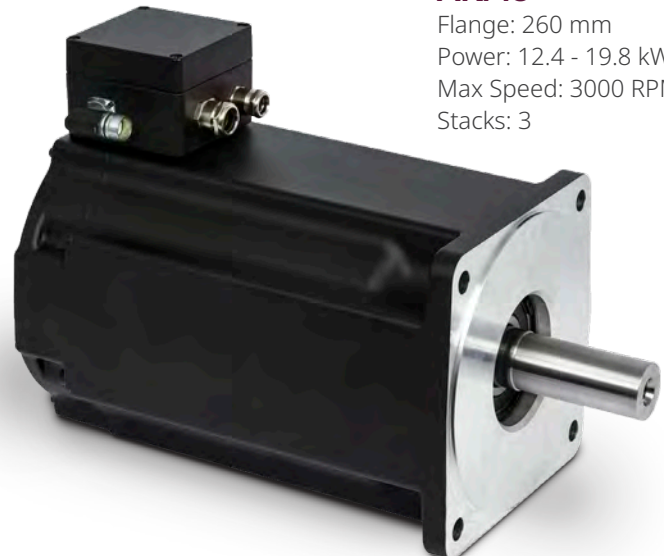

## AKM8

Flange: 260 mm  
Power: 12.4 - 19.8 kW  
Max Speed: 3000 RPM  
Stacks: 3

## AKM® Washdown and Food Grade

These motor variants are used in applications that are subject to strict hygiene regulations in which it is essential that the formation of nuclei and corrosion are avoided and in which machines must be cleaned cyclically. These motors are based on the standard types AKM2 – AKM6 with special modifications for use in the food-processing industry, in the packaging industry, or even outdoors. An option for AKM Washdown and Food Grade motors is to coat the flange.

### AKM® Washdown

Part Numbers:

AKMxxx-xxxxx-0W: Washdown with unpainted flange

AKMxxx-Wxxxx-0W: Washdown with painted flange

Note: The AKM Washdown motors must not come into contact with any unpacked food.

Application Area:	Harsh Environments, Outdoors
Application Examples:	Transport in the food and packaging area without contact with food, radar stations, and wind turbines
Standards:	UL, CSA, CE, RoHS
Surface:	Gray 2K paint
Immunity:	Against tested industrial cleaning agents*, corrosion-resistant
Degree of Protection:	IP67
Shaft:	303 Stainless steel (CSN417029)
Rotary Shaft Seal:	PTFE
Lubricant:	Industrial bearing grease, non-food-grade
Connector:	Stainless steel, smooth surface
Screws:	Stainless steel
Name Plate:	Engraved, additional name plate in the package



### AKM® Food Grade

Part Numbers:

AKMxxx-xxxxx-0F: Food Grade with unpainted flange

AKMxxx-Wxxxx-0F: Food Grade with painted flange

Note: The surface of the AKM Food Grade food motor has passed all tests as per FDA Global Migration for indirect contact with food. Any direct contact with unpacked food is not permitted.

Application Examples:	Food and beverages industries; cutting, packing, and filling without direct contact with food; motor positioned laterally or below the food.
Standards:	UL, CSA, CE, RoHS, FDA
Surface:	White 2K FDA compliant paint**
Immunity:	Against tested industrial cleaning agents*, corrosion-resistant
Degree of Protection:	IP67
Shaft:	303 Stainless steel (CSN417029)
Rotary Shaft Seal:	PTFE as per FDA
Lubricant:	Food grade as per FDA
Connector:	Stainless steel, smooth surface
Screws:	Stainless steel
Name Plate:	Engraved, additional name plate in the package



\* Resistance of the AKM Washdown and AKM Food Grade surfaces to the following industrial cleaning agents has been tested: P3-topactive DES, P3-topactive LA, P3-topax 56, P3-topax 66, P3-topax 91

\*\*Meets FDA global migration standards

# AKM® Model Nomenclature

## AKM® Brushless Servo Motor

**AKM 6 2 P - A N C N DA 00**

AKM Series

Flange Size

- 1 40 mm
- 2 58 mm
- 3 70 mm
- 4 84 mm
- 5 108 mm
- 6 138 mm
- 7 188 mm
- 8 260 mm

Rotor Stack Length

AKMx Availability	
	1 2 3 4 5 6 7 8
1   1 stack	• • • • • • • •
2   2 stacks	• • • • • • • •
3   3 stacks	• • • • • • • •
4   4 stacks	• • • • • • • •
5   5 stacks	• • • • • • • •

Winding Type

A to Z

S Special

Mount

A IEC with tolerance N

B NEMA

C Alternative IEC standard

D Other standard

G Alternative IEC standard

H Alternative IEC standard

R IEC with tolerance R

M, T Reinforced bearing AKM8

W Flange coating for Washdown, IEC

S Special

Shaft

C Keyway

K Open keyway

N Smooth shaft

S Special

Customization/Seal

00 Standard motor without shaft seal (IP54 rating)

01 With shaft seal (IP65 rating)

0F Food Grade (IP67 rating)

0W Washdown (IP67 rating)

XX Customization

Feedback Device

For all options see following page

S Special

Brake

2 24 V holding brake

N Without brake

S Special

Connectors

For all option details see following page

B Dual 90° M23 Intercontec connectors, motor-mounted (AKM2 only)

C Dual straight M23 Intercontec connectors, on 0.5 m shielded leads (AKM1-AKM2)

C Dual 90° M23 Intercontec connectors, motor-mounted (AKM3-AKM7)

9 Single 90° itec connector, motor-mounted (AKM1 only)

9 Single 90° M23 Intercontec connector, motor-mounted (AKM2-AKM6)

G Dual straight M23 Intercontec connector, motor-mounted (AKM2-AKM7)

H Dual 90° M40 Intercontec connector and M23 Intercontec feedback connector, motor-mounted (AKM74QT & AKM82T)

M Dual molex connectors, on 0.5 m shielded leads (AKM1-AKM4)

P Single Molex connector, on 0.5 m shielded leads (AKM1-AKM4)

T Dual terminal box for power and M23 Intercontec feedback connector, motor-mounted (AKM8)

Y Single ytec connector, motor-mounted (AKM1 only)

Note: These connector options are only valid for the "00" and "01" customization/seal option variants. Stainless Steel Hummel connectors are used for AKM Washdown (0W) and AKM Food Grade (0F) variants.

Base Model	Mount-Shaft Availability																										
	AC	AK	AN	BK	BN	CC	CK	CN	DC	DK	DN	EF	EK	EN	GC	GN	HC	HN	KK	LK	MC	MN	TC	TN	WC	WN	
AKM1		•	•		•		•	•																			
AKM2	•		•	•	•		•	•	•		•	•	•	•											•	•	
AKM3	•		•			•		•							•	•									•	•	
AKM4	•		•	•		•		•					•	•	•	•			•						•	•	
AKM5	•		•	•		•		•		•			•	•	•	•			•						•	•	
AKM6	•		•			•		•							•	•			•	•					•	•	
AKM7	•		•			•		•							•	•			•						•	•	
AKM8	•		•			•		•							•	•	•	•	•				•	•	•	•	

Note: Options shown in blue text are considered standard.

## Feedback Unit Options

Feedback Unit Options				Feedback Resolution				
Code	Designation	AKM Frame Size	Single-Turn or Multi-Turn	Device Resolution (Sin/Cos per Rev., Bits or Lines/Rev.)	AKD Internal Resolution	AKD2G Internal Resolution	# of Absolute Revs.	Accuracy (± arc-mins)
1-	Commutating Encoder	1-8	Single-Turn	1024 Lines	4,096	4,096	None	1
2-				2048 Lines	8,192	8,192		
ED		2-8		500 Lines	2,000	2,000		
EE				1000 Lines	4,000	4,000		
EF				2000 Lines	8,000	8,000		
EG				2500 Lines	10,000	10,000		
EH				5000 Lines	20,000	20,000		
EJ				10000 Lines	40,000	40,000		
EM				4096 Lines	16,384	16,384		
EN				8192 Lines	32,768	32,768		
AA	BISS B Optical Sine Encoder	2-4	Single-turn	2048 Sin/Cos	27-Bits	32-Bits	1	0.6
AB		5-8	Multi-turn				4,096	
C-	SFD Smart Feedback Device	1	Single-turn	24-Bits	24-Bits	24-Bits	1	15
		2-4						8
		5-8						9
CA	SFD3 Smart Feedback Device, Gen. 3	1	Single-turn	24-Bits	24-Bits	24-Bits	1	15
		2-4						8
		5-6						9
CB	SFD-M Smart Feedback Device, Multi-turn	2-6	Multi-turn	24-Bits	24-Bits	24-Bits	65,536	1
GE	HIPERFACE DSL® Optical Encoder	2-6	Single-turn	18-Bits	18-Bits	18-Bits	1	1.33
GF			Multi-turn				4,096	
GA/GJ*	HIPERFACE Optical Sin/Cos Encoder	2-8	Single-turn	128 Sin/Cos	23-Bits	31-Bits	1	1.33
GB/GK*			Multi-turn				4,096	
GP**	HIPERFACE Capacitive Encoder	1	Single-turn	16 Sin/Cos	20-Bits	28-Bits	1	4.8
GR**			Multi-turn				4,096	
DA	EnDat® 2.2/01 Optical Sine Encoder	2-4	Single-turn	512 Sin/Cos	25-Bits	32-Bits	1	1
DB		5-8		2048 Sin/Cos	27-Bits			0.333
	LA	EnDat® 2.2/22 Inductive Encoder	2-4	Multi-turn	512 Sin/Cos	25-Bits	32-Bits	4,096
5-8			2048 Sin/Cos		27-Bits	0.333		
LB	EnDat® 2.2/22 Inductive Encoder	2-3	Single-turn	18-Bits	18-Bits	18-Bits	1	4.67
		4-8		19-Bits	19-Bits	19-Bits		3
R-	Resolver Inductive Encoder	2-3	Multi-turn	18-Bits	18-Bits	18-Bits	4,096	4.67
		4-8		19-Bits	19-Bits	19-Bits		3
R-	Resolver Inductive Encoder	1	Single-Turn	1 pole pair (16-Bits)	16-Bits	16-Bits	1	15
		2-4						10
		5-8						9

\*ServoStar (Sxxx)/AKD mapped respectively  
 \*\*AKD mapped ONLY

### Related Resources:

[Feedback Option Specifications](#)  
[Connector Options and Pinouts](#)  
[Thermal Device Options](#)

## Connector Options

Code	Thermal Sensor*	Used with	IP Rating**	Connection type	Description
B	PTC	AKM2	IP65	2 SpeedTec Ready connectors, size 1.0 (M23)	Angled, rotatable, mounted on motor
C	PTC	AKM1-AKM2	IP65	2 SpeedTec Ready connectors, size 1.0 (M23)	On 0.5m cable
C	PTC	AKM3-AKM7	IP65	2 SpeedTec Ready connectors, size 1.0 (M23)	Angled, rotatable, mounted on motor
9	PT1000	AKM1	IP65	1 hybrid itec connector	Rotatable, mounted on motor
9	PT1000	AKM2-AKM6	IP65	1 SpeedTec Ready connector, size 1.0 (M23)	Angled, rotatable, mounted on motor
G	PTC	AKM2-AKM7	IP67	2 SpeedTec Ready connectors, size 1.0 (M23)	Straight, mounted on motor
H	PTC	AKM7 & AKM82T	IP65	1 feedback threaded connector, size 1.0 (M23) 1 power threaded connector, size 1.5 (M40)	Angled, rotatable, mounted on motor
M	PTC	AKM1-AKM4	IP20	2 Molex connectors, $I_C < 6$ A	On 0.5m cable
P	PTC	AKM1-AKM4	IP20	1 Molex connector, $I_C < 6$ A	On 0.5m cable
T	PTC	AKM8	IP65	1 terminal box for power 1 feedback threaded connector, size 1.0 (M23)	Mounted on motor
Y	PTC	AKM1	IP65	1 ytec connector	Rotatable, mounted on motor

NOTE: These connector options are only valid for the "00" or "01" Customization/Seal Option variants. Stainless Steel Hummel connectors are used for AKM Washdown (0W) and AKM Food Grade (0F) variants.

\*For Thermal Device Curves, reference see the Thermal Sensor Protective Devices page.

\*\*IP ratings shown apply ONLY to the connector and the connector base/bushing on motor.

# AKM® Model Nomenclature

## Feedback and Connector Availability

AKM1		C	9	M	P	Y
Feedback Code	R-	•		•		•
	1-, 2-	•		•		•
	C-	•		•	•	•
	CA		•			
	GP, GR	•				•

AKM2		B	C	9	G	M	P
Feedback Code	R-	•	•		•	•	
	1-, 2-	•	•		•	•	
	Ex	•	•		•	•	
	AA, AB	•	•		•	•	
	C-	•	•	•	•	•	•
	CA,CB			•			
	DA,DB	•	•		•	•	
	LA, LB	•	•		•	•	
	GA, GB	•			•		
	GE, GF			•			
	GJ, GK	•			•		

AKM3		C	9	G	M	P
Feedback Code	R-	•		•	•	
	1-, 2-	•		•	•	
	Ex	•		•	•	
	AA, AB	•		•	•	
	C-	•	•	•	•	•
	CA,CB		•			
	DA,DB	•		•	•	
	LA, LB	•		•	•	
	GA, GB	•		•		
	GE, GF		•			

AKM4		C	9	G	M	P
Feedback Code	R-	•		•	•	
	1-, 2-	•		•	•	
	Ex	•		•	•	
	AA, AB	•		•	•	
	C-	•	•	•	•	•
	CA,CB		•			
	DA,DB	•		•	•	
	LA, LB	•		•	•	
	GA, GB	•		•		
	GE, GF		•			

AKM5		C	9	G
Feedback Code	R-	•		•
	1-, 2-	•		•
	Ex	•		•
	AA, AB	•		•
	C-	•		•
	CA,CB		•	
	DA,DB	•		•
	LA, LB	•		•
	GA, GB	•		•
	GE, GF		•	

AKM6		C	9	G
Feedback Code	R-	•		•
	1-, 2-	•		•
	Ex	•		•
	AA, AB	•		•
	C-	•		•
	CA,CB		•	
	DA,DB	•		•
	LA, LB	•		•
	GA, GB	•		•
	GE, GF		•	

AKM7		C	G	H*
Feedback Code	R-	•	•	•
	1-, 2-	•	•	•
	Ex	•	•	•
	AA, AB	•	•	•
	C-	•	•	•
	DA,DB	•	•	•
	LA, LB	•	•	•
	GA, GB	•	•	•
	GJ, GK	•	•	•

\*AKM74Q Only

AKM8		H*	T
Feedback Code	R-	•	•
	1-, 2-	•	•
	Ex	•	•
	AA, AB	•	•
	C-	•	•
	DA,DB	•	•
	LA, LB	•	•
	GJ, GK	•	•

\*AKM82T Only

Related Resources:  
[Feedback Option Specifications](#)  
[Connector Options and Pinouts](#)

# AKM® Tested with AKD Servo Drives

The AKM performance data and curves in this guide were acquired using Kollmorgen's AKD family of servo drives. Please go to <https://www.kollmorgen.com/en-us/products/drives/servo/servo-drives> or contact Kollmorgen Customer Support for detailed specifications and to learn how pairing them with the AKM servo motor can optimized system performance.



AKD® Product Family

Parameter	AKD2G	AKD	AKD BASIC	AKD PDMM	AKD-N/AKD-C
Base I/O	12 digital 2 analog	11 digital 2 analog	11 digital 2 analog	17 digital 2 analog	5 digital
Expansion I/O <sup>1</sup>	8 digital 2 analog *Drive size is the same	No	20 digital 2 analog *adds 30 mm to the drive width for drives up to 12A	Up to 1000+ remote I/O via EtherCAT	No
Safe I/O	2 digital inputs for Safey option 1 4 digital inputs for SafeMotion options	No	No	No	No
SafeMotion <sup>2</sup>	Yes	STO only	STO only	STO only	STO only
Optimized for single cable <sup>3</sup>	Yes	No	No	No	Yes
Continuous current limit <sup>4</sup>	24A	48A	48A	48A	12A
Connectivity <sup>5</sup>	Analog, EtherCAT, CANopen, Profinet IRT, Ethernet/IP, TCP/IP, Modbus/TCP	Analog, EtherCAT, CANopen, Profinet RT, Ethernet/IP, TCP/IP, Modbus/TCP	Analog	EtherCAT, CANopen, Profinet RT, Ethernet/ IP, TCP/IP, Modbus/TCP	EtherCAT
Axis Configuration	single or dual	single	single	single	single
Drive-resident controller	No	No	No	Yes	No
Programmability	parameterized, 2 axes control loops, action table	parameterized	parameterized, BASIC programmable	parameterized, IEC 61131-3 via PLCo- pen or Pipe Network	parameterized
Graphical Display	160x128-pixel display	2 digit LED	2 digit LED	3 digit LED	Status LED
Removeable Memory <sup>6</sup>	Yes	No	Yes	Yes	No
System Architecture	Centralized	Centralized	Centralized	Centralized	Decentralized
IP Rating	IP20	IP20	IP20	IP20	IP67 (AKD-N)

Notes:

- 1: Add EtherCAT multi-axis master, PCMM, to the AKD drive family to enable remote I/O expansion via EtherCAT. PCMM controller functionality is built into the PDMM
- 2: SafeMotion includes FSoE, STO, SS1, SS2, SOS, SDB, SBC/SBT, SLS, SSR, SSM, SDI, SAR, SLA, SLI, SLP, SCA up to SIL3 / PLe
- 3: Single cable optimized means one single cable for power & motor feedback with 1 connector at motor end and 1 connector at drive end
- 4: Higher power variants under development in some models. Consult factory for availability.
- 5: Consult factory on connectivity options for AKD2G. Profinet and Ethernet/IP will be added in 2021
- 6: Optional integrated SD card for easy backup and drive cloning

# AKM<sup>®</sup> Servo Motor Quick Guide

## AKM, AKM Washdown, and AKM Food Grade

### Performance Data

AKM Servo Motor	Flange size [mm]	Continuous Torque Tcs [Nm]	Continuous Current Ics [A]	Peak Torque Tp [Nm]	75 Vdc			120 Vac (160 Vdc)			240 Vac (320 Vdc)			400 Vac (560 Vdc)			480 Vac (640 Vdc)			Inertia (Jm) [kg·cm <sup>2</sup> ]	Weight [kg]
					Rated Speed Nrted [RPM]	Rated Torque Trtd [Nm]	Rated Power Prtd [kW]	Rated Speed Nrted [RPM]	Rated Torque Trtd [Nm]	Rated Power Prtd [kW]	Rated Speed Nrted [RPM]	Rated Torque Trtd [Nm]	Rated Power Prtd [kW]	Rated Speed Nrted [RPM]	Rated Torque Trtd [Nm]	Rated Power Prtd [kW]	Rated Speed Nrted [RPM]	Rated Torque Trtd [Nm]	Rated Power Prtd [kW]		
11B	40	0.18	1.16	0.61	-	-	-	4000	0.18	0.08	8000	0.17	0.14	-	-	-	-	-	-	0.017	0.35
11C	40	0.18	1.45	0.61	-	-	-	6000	0.18	0.11	-	-	-	-	-	-	-	-	-	0.017	0.35
11E	40	0.18	2.91	0.61	6000	0.18	0.11	-	-	-	-	-	-	-	-	-	-	-	-	0.017	0.35
12C	40	0.31	1.51	1.08	-	-	-	4000	0.30	0.13	8000	0.28	0.23	-	-	-	-	-	-	0.031	0.49
12E	40	0.31	2.72	1.05	3000	0.31	0.10	8000	0.28	0.23	-	-	-	-	-	-	-	-	-	0.031	0.49
13C	40	0.41	1.48	1.46	-	-	-	3000	0.41	0.13	8000	0.36	0.30	-	-	-	-	-	-	0.045	0.63
13D	40	0.40	2.40	1.44	2000	0.40	0.08	7000	0.36	0.27	-	-	-	-	-	-	-	-	-	0.045	0.63
21C	58	0.48	1.58	1.47	-	-	-	2500	0.46	0.12	8000	0.39	0.32	-	-	-	-	-	-	0.11	0.82
21E	58	0.50	3.11	1.49	2000	0.48	0.10	7000	0.41	0.30	-	-	-	-	-	-	-	-	-	0.11	0.82
21G	58	0.50	4.87	1.51	4000	0.46	0.19	-	-	-	-	-	-	-	-	-	-	-	-	0.11	0.82
22C	58	0.84	1.39	2.73	-	-	-	1000	0.83	0.09	3500	0.78	0.29	8000	0.68	0.57	8000	0.68	0.57	0.16	1.10
22E	58	0.87	2.73	2.76	1000	0.85	0.09	3500	0.81	0.30	8000	0.70	0.59	-	-	-	-	-	-	0.16	1.10
22G	58	0.88	4.82	2.79	2500	0.83	0.22	7000	0.74	0.54	-	-	-	-	-	-	-	-	-	0.16	1.10
23C	58	1.13	1.41	3.81	-	-	-	1000	1.11	0.12	2500	1.08	0.28	5500	0.99	0.57	7000	0.95	0.70	0.22	1.38
23D	58	1.16	2.19	3.84	-	-	-	1500	1.12	0.18	5000	1.03	0.54	8000	0.92	0.77	8000	0.92	0.77	0.22	1.38
23E	58	1.16	2.78	3.86	-	-	-	2500	1.1	0.29	6500	0.98	0.67	8000	0.87	0.73	-	-	-	0.22	1.38
23F	58	1.18	4.31	3.88	1500	1.15	0.18	4500	1.07	0.50	8000	0.94	0.79	-	-	-	-	-	-	0.22	1.38
24C	58	1.38	1.42	4.73	-	-	-	-	-	-	2000	1.32	0.28	4500	1.25	0.59	5500	1.22	0.70	0.27	1.66
24D	58	1.41	2.21	4.76	-	-	-	1500	1.36	0.21	4000	1.29	0.54	8000	1.11	0.93	8000	1.11	0.93	0.27	1.66
24E	58	1.40	2.79	4.79	-	-	-	2000	1.34	0.28	5500	1.24	0.71	8000	1.12	0.82	-	-	-	0.27	1.66
24F	58	1.42	3.89	4.82	1000	1.39	0.15	3000	1.33	0.42	8000	1.12	0.94	-	-	-	-	-	-	0.27	1.66
31C	70	1.15	1.37	3.88	-	-	-	-	-	-	2500	1.12	0.29	5000	1.00	0.52	6000	0.91	0.57	0.33	1.55
31E	70	1.20	2.99	4.00	750	1.19	0.09	2500	1.17	0.31	6000	0.95	0.60	-	-	-	-	-	-	0.33	1.55
31H	70	1.23	5.85	4.06	2000	1.20	0.25	6000	0.97	0.61	-	-	-	-	-	-	-	-	-	0.33	1.55
32C	70	2.00	1.44	6.92	-	-	-	-	-	-	1500	1.95	0.31	3000	1.86	0.58	3500	1.83	0.67	0.59	2.23
32D	70	2.04	2.23	7.10	-	-	-	1000	2.00	0.21	2500	1.93	0.51	5500	1.65	0.95	6000	1.58	0.99	0.59	2.23
32E	70	2.04	2.82	7.11	-	-	-	-	-	-	3500	1.87	0.69	7000	1.41	1.03	7000	1.22	1.02	0.59	2.23
32H	70	2.10	5.50	7.26	1200	2.06	0.26	3000	1.96	0.62	7000	1.45	1.06	-	-	-	-	-	-	0.59	2.23
33C	70	2.71	1.47	9.76	-	-	-	-	-	-	1000	2.64	0.28	2000	2.54	0.53	2500	2.50	0.65	0.85	2.9
33E	70	2.79	2.58	9.96	-	-	-	-	-	-	2000	2.62	0.55	4500	2.34	1.10	5000	2.27	1.19	0.85	2.9
33H	70	2.88	5.62	10.22	800	2.82	0.24	2500	2.66	0.70	5500	2.27	1.31	-	-	-	-	-	-	0.85	2.9
41C	84	1.95	1.46	6.12	-	-	-	-	-	-	1200	1.88	0.24	3000	1.77	0.56	3500	1.74	0.64	0.81	2.44
41E	84	2.02	2.85	6.28	-	-	-	1200	1.94	0.24	3000	1.82	0.57	6000	1.58	0.99	6000	1.58	0.99	0.81	2.44
41H	84	2.06	5.6	6.36	1000	1.99	0.21	3000	1.86	0.58	6000	1.62	1.02	-	-	-	-	-	-	0.81	2.44
42C	84	3.35	1.40	11.3	-	-	-	-	-	-	-	-	-	1500	3.10	0.49	2000	3.02	0.63	1.5	3.39
42E	84	3.42	2.74	11.3	-	-	-	-	-	-	1800	3.12	0.59	3500	2.81	1.03	4000	2.72	1.14	1.5	3.39
42G	84	3.53	4.80	11.5	-	-	-	-	-	-	3500	2.90	1.06	6000	2.35	1.48	6000	2.35	1.48	1.5	3.39
42H	84	3.54	5.90	11.6	-	-	-	2000	3.2	0.67	4500	2.72	1.28	-	-	-	-	-	-	1.5	3.39
42J	84	3.56	8.4	11.6	-	-	-	3000	3.03	0.95	6000	2.36	1.50	-	-	-	-	-	-	1.5	3.39
43E	84	4.70	2.76	15.9	-	-	-	-	-	-	1500	4.24	0.67	2500	3.92	1.03	3000	3.76	1.18	2.1	4.35
43G	84	4.80	4.87	16.1	-	-	-	-	-	-	2500	4.00	1.05	5000	3.01	1.58	6000	2.57	1.61	2.1	4.35
43H	84	4.82	5.40	16.1	-	-	-	1200	4.46	0.56	3000	3.86	1.21	5500	2.81	1.62	-	-	-	2.1	4.35
43K	84	4.90	9.60	16.4	-	-	-	2500	4.08	1.07	6000	2.62	1.65	-	-	-	-	-	-	2.1	4.35
43L	84	4.73	11.2	16.0	-	-	-	3000	3.78	1.19	6000	2.53	1.59	-	-	-	-	-	-	2.1	4.35
44E	84	5.76	2.90	19.9	-	-	-	-	-	-	1200	5.22	0.66	2000	4.80	1.01	2500	4.56	1.19	2.7	5.3
44G	84	5.88	5.00	20.2	-	-	-	-	-	-	2000	4.90	1.03	4000	3.76	1.57	5000	3.19	1.67	2.7	5.3
44H	84	5.89	5.6	20.0	-	-	-	-	-	-	2500	4.66	1.22	5000	3.19	1.67	6000	2.70	1.70	2.7	5.3
44J	84	6.00	8.80	20.4	-	-	-	-	-	-	4000	3.84	1.61	6000	2.75	1.73	6000	2.75	1.73	2.7	5.3
44K	84	5.88	10.1	20.2	-	-	-	2000	4.9	1.03	5000	3.18	1.67	-	-	-	-	-	-	2.7	6.3
51E	108	4.70	2.75	11.6	-	-	-	-	-	-	1200	4.41	0.55	2500	3.98	1.04	3000	3.80	1.19	3.4	4.2
51G	108	4.75	4.84	11.7	-	-	-	-	-	-	2500	4.02	1.05	5000	2.62	1.37	6000	1.94	1.22	3.4	4.2
51H	108	4.79	6.00	11.7	-	-	-	-	-	-	3000	3.87	1.22	6000	1.95	1.23	6000	1.95	1.23	3.4	4.2
51K	108	4.90	9.40	11.9	-	-	-	2500	4.15	1.09	5500	2.35	1.35	-	-	-	-	-	-	3.4	4.2
51L	108	4.89	11.9	12	-	-	-	3000	3.95	1.24	6000	2.00	1.26	-	-	-	-	-	-	3.4	4.2

Performance curves can be generated using our online [Performance Curve Generator Tool](#)

Performance Data (continued)

AKM Servo Motor	Frame size [mm]	Continuous Torque Tcs [Nm]	Continuous Current Ics [A]	Peak Torque Tp [Nm]	120 Vac (160 Vdc)			240 Vac (320 Vdc)			400 Vac (560 Vdc)			480 Vac (640 Vdc)			Inertia (Jm) [kg·cm <sup>2</sup> ]	Weight [kg]
					Rated Speed Nrtd [RPM]	Rated Torque Trtd [Nm]	Rated Power Prtd [kW]	Rated Speed Nrtd [RPM]	Rated Torque Trtd [Nm]	Rated Power Prtd [kW]	Rated Speed Nrtd [RPM]	Rated Torque Trtd [Nm]	Rated Power Prtd [kW]	Rated Speed Nrtd [RPM]	Rated Torque Trtd [Nm]	Rated Power Prtd [kW]		
52E	108	8.34	2.99	21.3	-	-	-	-	-	-	1500	7.61	1.20	2000	7.28	1.52	6.2	5.8
52G	108	8.43	4.72	21.5	-	-	-	1500	7.69	1.21	2500	7.06	1.85	3000	6.66	2.09	6.2	5.8
52H	108	8.48	5.90	21.6	-	-	-	1800	7.53	1.42	3500	6.26	2.30	4000	5.77	2.42	6.2	5.8
52K	108	8.60	9.30	21.9	-	-	-	3000	6.80	2.14	5500	3.90	2.25	6000	3.25	2.04	6.2	5.8
52L	108	8.67	11.6	22.0	-	-	-	3500	6.40	2.35	6000	3.27	2.06	6000	3.27	2.03	6.2	5.8
52M	108	8.60	13.1	21.9	2000	7.5	1.57	4500	5.20	2.45	-	-	-	-	-	-	6.2	5.8
53G	108	11.4	4.77	29.9	-	-	-	1000	10.7	1.12	2000	9.85	2.06	2400	9.50	2.39	9.1	7.4
53H	108	11.5	6.60	30.0	-	-	-	-	-	-	3000	8.63	2.77	3500	8.23	3.02	9.1	7.4
53K	108	11.6	9.40	30.3	-	-	-	2000	10.1	2.12	4000	7.65	3.20	4500	6.85	3.23	9.1	7.4
53L	108	11.6	11.8	30.3	-	-	-	3000	8.9	2.80	5500	5.00	2.88	6000	4.05	2.55	9.1	7.4
53M	108	11.4	13.4	29.7	-	-	-	3000	8.72	2.74	-	-	-	-	-	-	9.1	7.4
53P	108	11.4	19.1	29.8	-	-	-	5000	5.88	3.08	-	-	-	-	-	-	9.1	7.4
53Q	108	11.57	21.1	30.2	2500	9.58	2.51	5500	4.99	2.87	-	-	-	-	-	-	9.1	7.4
54G	108	14.3	5.00	38.0	-	-	-	-	-	-	1500	12.9	2.03	2000	12.3	2.57	12	9
54H	108	14.2	5.50	37.5	-	-	-	1000	13.4	1.40	1800	12.6	2.38	2000	12.2	2.56	12	9
54K	108	14.4	9.7	38.4	-	-	-	1800	12.7	2.39	3500	10.0	3.68	4000	9.25	3.87	12	9
54L	108	14.1	12.5	37.5	-	-	-	2500	11.5	3.00	4500	8.13	3.83	-	-	-	12	9
54N	108	14.1	17.8	37.6	1500	12.8	2.01	3500	9.85	3.61	-	-	-	-	-	-	12	9
54P	108	14.36	19.6	38.04	2000	12.4	3.63	4000	9.23	3.87	-	-	-	-	-	-	12	9
62G	138	11.9	4.9	29.7	-	-	-	-	-	-	1800	10.4	1.96	2000	10.2	2.14	17	8.9
62H	138	11.9	5.4	29.6	-	-	-	1000	11.2	1.17	2000	10.2	2.14	2400	9.9	2.49	17	8.9
62K	138	12.2	9.6	30.2	-	-	-	2000	10.4	2.18	3500	9.00	3.30	4500	8.00	3.77	17	8.9
62L	138	12.2	12.0	30.1	-	-	-	2500	10.0	2.62	5000	7.42	3.89	6000	5.74	3.61	17	9.8
62M	138	12.2	13.4	30.2	-	-	-	3000	9.50	2.98	6000	5.70	3.58	6000	5.70	3.58	17	8.9
62P	138	12.3	18.8	30.3	-	-	-	4500	8.10	3.82	-	-	-	-	-	-	17	8.9
62Q	138	12.0	21.8	29.8	-	-	-	5500	6.5	3.74	-	-	-	-	-	-	17	8.9
63G	138	16.5	4.5	41.8	-	-	-	-	-	-	1200	14.9	1.87	1500	14.6	2.29	24	11.1
63H	138	16.6	5.6	42.1	-	-	-	-	-	-	1500	14.6	2.29	1800	14.2	2.68	24	11.1
63K	138	16.8	9.9	42.6	-	-	-	1500	14.9	2.34	3000	12.9	4.05	3500	12.0	4.40	24	11.1
63L	138	16.8	11.1	42.6	-	-	-	1800	14.4	2.71	3000	12.9	4.05	3500	12	4.4	24	11.1
63M	138	17.0	13.8	43.0	-	-	-	2000	14.3	2.99	4000	11.3	4.73	4500	10.5	4.95	24	11.1
63N	138	17.0	17.4	43.0	-	-	-	3000	13.0	4.08	5000	9.60	5.03	6000	7.00	4.40	24	11.1
63Q	138	16.7	22.4	42.4	-	-	-	3500	11.9	4.36	-	-	-	-	-	-	24	11.1
64K	138	20.8	9.2	53.5	-	-	-	1200	18.8	2.36	2000	17.2	3.60	2500	16.3	4.27	32	13.3
64L	138	21.0	12.8	54.1	-	-	-	1500	18.4	2.89	3000	15.6	4.90	3500	14.4	5.28	32	13.3
64P	138	20.4	18.6	52.9	-	-	-	2500	16.0	4.19	4500	11.9	5.62	5500	9.00	5.18	32	13.3
64Q	138	20.6	20.7	53.2	-	-	-	3000	15.3	4.81	5000	10.7	5.60	6000	7.40	4.65	32	13.3
65K	138	24.8	9.8	64.5	-	-	-	1000	22.8	2.39	2000	20.2	4.23	2200	19.7	4.54	40	15.4
65L	138	25.0	12.2	65.2	-	-	-	1300	22.4	3.05	2500	19.2	5.03	2800	18.6	5.37	40	15.4
65M	138	25.0	13.6	65.2	-	-	-	1500	21.9	3.44	2700	18.8	5.32	3000	18.1	5.69	40	15.4
65N	138	24.3	17.8	63.7	-	-	-	2000	19.8	4.15	3500	16.0	5.86	4000	14.7	6.16	40	15.4
65P	138	24.5	19.8	64.1	-	-	-	2400	19.1	4.8	4000	14.9	6.24	5000	11.6	6.08	40	15.4
72K	188	29.7	9.3	79.4	-	-	-	-	-	-	1500	25.1	3.94	1800	24.0	4.52	65	19.7
72L	188	30	11.5	79.5	-	-	-	-	-	-	1800	24.3	4.58	2000	23.6	4.94	65	19.7
72M	188	30.0	13.0	79.8	-	-	-	-	-	-	2000	23.6	4.94	2500	22.1	5.79	65	19.7
72P	188	29.4	18.7	78.5	-	-	-	1800	23.8	4.49	3000	20.1	6.31	3500	18.2	6.67	65	19.7
72Q	188	29.5	23.5	78.4	-	-	-	2000	23.2	4.89	4000	16.3	6.83	4500	14.1	6.65	65	19.7
73L	188	42.0	12.1	113	-	-	-	-	-	-	1400	34.4	5.04	1500	33.8	5.31	92	26.7
73M	188	42.0	13.6	112	-	-	-	-	-	-	1500	33.8	5.31	1800	32.1	6.05	92	26.7
73P	188	41.6	19.5	111	-	-	-	1300	34.7	4.72	2400	28.5	7.16	2800	26.3	7.71	92	26.7
73Q	188	41.5	24.5	111	-	-	-	1500	33.4	5.25	3000	25.2	7.92	3500	22	8.07	92	26.7
74L	188	53.0	12.9	143	-	-	-	-	-	-	1200	43.5	5.47	1400	41.5	6.08	120	33.6
74P	188	52.5	18.5	142	-	-	-	-	-	-	1800	39.6	7.46	2000	35.9	7.52	120	33.6
74Q	188	52.2	26.1	141	-	-	-	1300	41.9	5.71	2500	31.5	8.25	3000	27.3	8.58	120	33.6
82T	260	75	48	175	-	-	-	-	-	-	2500	47.5	12.4	3000	38.0	11.9	172	49
83T	260	130	65	310	-	-	-	-	-	-	2200	70.0	16.1	2500	60.0	15.7	334	73
84T	260	180	67	434	-	-	-	-	-	-	1800	105	19.8	2000	93.0	19.5	495	97

Performance curves can be generated using our online [Performance Curve Generator Tool](#)

# AKM1x Series Motor Specifications

## AKM1x Performance Data – Up to 240 Vac (320 Vdc Bus) voltage

Parameters	Tol	Symbol	Units	AKM11			AKM12		AKM13	
				B	C	E	C	E	C	D
Max Rated Voltage ⑩	Max	-	Vac	240	120	-	240	120	240	120
			Vdc	320	160	75	320	160	320	160
Continuous Torque for $\Delta T$ winding = 100°C ①②⑦⑧	Nom	$T_{CS}$	Nm	0.183	0.185	0.185	0.310	0.310	0.409	0.401
			lb-in	1.62	1.64	1.64	2.75	2.71	3.62	3.55
Continuous Current for $\Delta T$ winding = 100°C ①②⑦⑧	Nom	$I_{CS}$	$A_{RMS}$	1.16	1.45	2.91	1.51	2.72	1.48	2.40
Continuous Torque for $\Delta T$ winding = 60°C ②	Nom	$T_{CS}$	Nm	0.146	0.148	0.148	0.248	0.248	0.327	0.320
			lb-in	1.29	1.31	1.31	2.19	2.19	2.89	2.83
Max Mechanical Speed ⑤	Nom	$N_{max}$	rpm	8000	8000	8000	8000	8000	8000	8000
Peak Torque ①②	Nom	$T_p$	Nm	0.61	0.61	0.61	1.08	1.05	1.46	1.44
			lb-in	5.39	5.43	5.41	9.6	9.3	12.9	12.7
Peak Current	Nom	$I_p$	$A_{RMS}$	4.65	5.79	11.7	6.06	10.9	5.93	9.6
75 Vdc Rated Torque (speed) ①②⑦⑧		$T_{Rtd}$	Nm	-	-	0.176	-	0.305	-	0.401
			lb-in	-	-	1.56	-	2.7	-	3.55
Rated Speed		$N_{Rtd}$	rpm	-	-	6000	-	3000	-	2000
Rated Power (speed) ①②⑦		$P_{Rtd}$	kW	-	-	0.11	-	0.10	-	0.08
			Hp	-	-	0.15	-	0.13	-	0.11
120 Vac (160 Vdc) Rated Torque (speed) ①②⑦⑧		$T_{Rtd}$	Nm	0.180	0.176	-	0.304	0.275	0.407	0.365
			lb-in	1.59	1.56	-	2.69	2.43	3.60	3.23
Rated Speed		$N_{Rtd}$	rpm	4000	6000	-	4000	8000	3000	7000
Rated Power (speed) ①②⑦		$P_{Rtd}$	kW	0.08	0.11	-	0.13	0.23	0.13	0.27
			Hp	0.10	0.15	-	0.17	0.31	0.17	0.36
240 Vac (320 Vdc) Rated Torque (speed) ①②⑦⑧		$T_{Rtd}$	Nm	0.167	-	-	0.279	-	0.364	-
			lb-in	1.48	-	-	2.47	-	3.22	-
Rated Speed		$N_{Rtd}$	rpm	8000	-	-	8000	-	8000	-
Rated Power (speed) ①②⑦		$P_{Rtd}$	kW	0.14	-	-	0.23	-	0.30	-
			Hp	0.19	-	-	0.31	-	0.41	-
400 Vac (560 Vdc) Rated Torque (speed) ①②⑦⑧		$T_{Rtd}$	Nm	-	-	-	-	-	-	-
			lb-in	-	-	-	-	-	-	-
Rated Speed		$N_{Rtd}$	rpm	-	-	-	-	-	-	-
Rated Power (speed) ①②⑦		$P_{Rtd}$	kW	-	-	-	-	-	-	-
			Hp	-	-	-	-	-	-	-
480 Vac (640 Vdc) Rated Torque (speed) ①②⑦⑧		$T_{Rtd}$	Nm	-	-	-	-	-	-	-
			lb-in	-	-	-	-	-	-	-
Rated Speed		$N_{Rtd}$	rpm	-	-	-	-	-	-	-
Rated Power (speed) ①②⑦		$P_{Rtd}$	kW	-	-	-	-	-	-	-
			Hp	-	-	-	-	-	-	-

See following page for notes.

## AKM1x Motor Parameters

Parameters	Tol	Symbol	Units	AKM11			AKM12		AKM13	
				B	C	E	C	E	C	D
Torque Constant ①	±10%	$K_t$	Nm/A <sub>rms</sub>	0.158	0.129	0.064	0.207	0.112	0.278	0.169
			lb-in/A <sub>rms</sub>	1.40	1.14	0.57	1.83	0.99	2.46	1.50
Back EMF Constant ②	±10%	$K_e$	V <sub>rms</sub> /krpm	10.2	8.3	4.1	13.3	7.2	17.9	10.9
Motor Constant	Nom	$K_m$	N-m/√W	0.0302	0.0303	0.0296	0.0480	0.0463	0.0618	0.0593
			lb-in/√W	0.267	0.268	0.262	0.425	0.410	0.547	0.525
Resistance (line-line) ③	±10%	$R_m$	ohm	18.2	12.1	3.11	12.4	3.9	13.5	5.41
Inductance (line-line)		L	mH	12.5	8.3	2.04	9.1	2.7	10.3	3.8
Inertia (includes Resolver feedback) ③	±10%	$J_m$	kg-cm <sup>2</sup>	0.017			0.031		0.045	
			lb-in-s <sup>2</sup>	1.5E-05			2.7E-05		4.0E-05	
Optional Brake Inertia (additional)	±10%	$J_m$	kg-cm <sup>2</sup>	0.0013			0.0013		0.0013	
			lb-in-s <sup>2</sup>	0.12E-05			0.12E-05		0.12E-05	
Weight (w/o brake) ④		W	kg	0.35			0.49		0.63	
			lb	0.8			1.1		1.4	
Static Friction ①⑧		$T_f$	Nm	0.0011			0.0021		0.0031	
			lb-in	0.01			0.02		0.03	
Viscous Damping ①		$K_{dv}$	Nm/krpm	0.0005			0.001		0.0015	
			lb-in/krpm	0.004			0.009		0.013	
Thermal Time Constant		TCT	minutes	4			6		7	
Thermal Resistance		$R_{thw-a}$	°C/W	1.83			1.63		1.53	
Operating Ambient Temperature Range ⑩⑪			°C	-20 to 40			-20 to 40		-20 to 40	
Pole Pairs				3			3		3	
Heat Sink Size				10"x10"x1/4" Aluminum Plate			10"x10"x1/4" Aluminum Plate		10"x10"x1/4" Aluminum Plate	

Additional windings may exist. Please contact Kollmorgen Customer Support for further information or to request custom winding options for your application requirements.

**Notes:**

- ① Motor winding temperature rise, ΔT=100°C, at 40°C ambient.
- ② All data referenced to sinusoidal commutation.
- ③ Add parking brake if applicable for total inertia.
- ④ Motor with standard heat sink.
- ⑤ May be limited at some values of Vbus.
- ⑥ Measured at 25°C.
- ⑦ For non-resolver feedback options: no continuous torque reduction.
- ⑧ For motors with optional shaft seal, reduce torque shown by 0.021 Nm (0.19 lb-in), and increase  $T_f$  by the same amount.
- ⑨ Brake option increases weight by 0.19 kg (0.42 lb).
- ⑩ Motors can be operated up to 240 Vac. For performances curves at voltages, listed or unlisted, please use our online Performance Curve Generator Tool.
- ⑪ Brake option will operate in this range in a non-condensing environment. See the Brake Option section for more information.
- ⑫ Operation outside of this range may be possible. Please contact Kollmorgen Customer Support with your application requirements.

**Related Resources:**

- [AKM® Servo Motor Quick Guide](#) (for typical torque/speed performance)
- [Performance Curve Generator Tool](#) (generate AKM model specific performance curves)
- [Brake Option](#) (detailed brake specifications)

# AKM1x Series Motor Specifications

## AKM1x Frame Dimensional Drawings

AKM 2D/3D CAD models can be found at [Kollmorgen.com/DesignTools](http://Kollmorgen.com/DesignTools)

### C-, M-, P- connector options

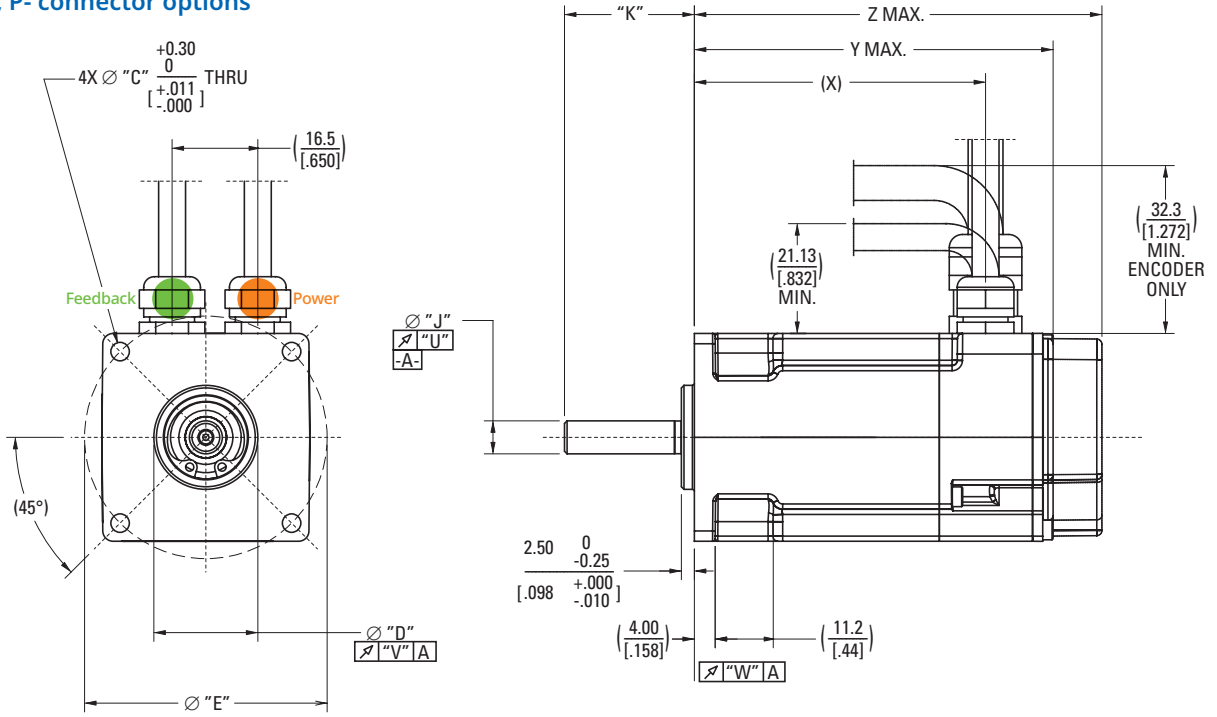

### ytec Y-connector option

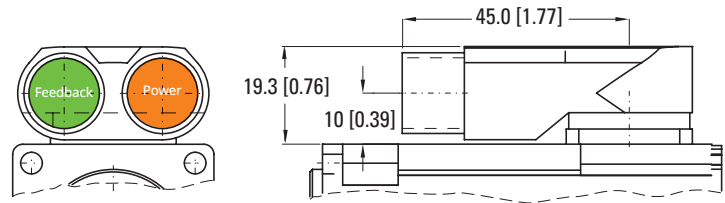

### itec 9-connector option

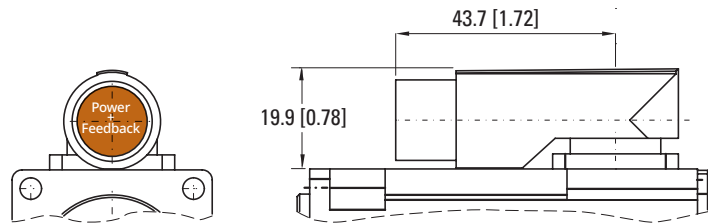

### Shaft-keyway dimensions

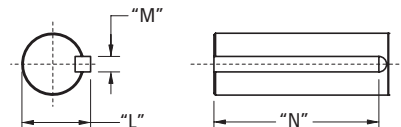

Dimensional data tables for callouts are located on the following page.

## AKM1x Frame Dimensional Data

### AKM1x Mounting Flange-Shaft Dimensional Data

Mounting Flange-Shaft	Hole Diameter "C"	Pilot Diameter "D"	Bolt Circle Dia. "E"	"F"	"H"	Shaft Diameter "J"	Shaft Length "K"
AK	4.30 [0.169]	30 [1.1811]	46 [1.811]	-	-	8 [0.3150]	25 [0.984]
AN	4.30 [0.169]	30 [1.1811]	46 [1.811]	-	-	8 [0.3150]	25 [0.984]
BN	3.56 [0.140]	20.02 [0.788]	46.69 [1.838]	-	-	6.350 [0.2500]	25 [0.984]
CK	3.40 [0.134]	30 [1.1811]	45 [1.772]	-	-	8 [0.3150]	25 [0.984]
CN	3.40 [0.134]	30 [1.1811]	45 [1.772]	-	-	8 [0.3150]	25 [0.984]

Mounting Flange-Shaft	Shaft Dia. w/ Key "L"	Key Width "M"	Key Length "N"
AK	9.20 [0.362]	3 [0.1181]	14 [0.551]
AN	-	-	-
BN	-	-	-
CK	9.20 [0.362]	3 [0.1181]	14 [0.551]
CN	-	-	-

### AKM1x Motor Length Dimensional Data

Connector	No Brake (N)						
	X		Y MAX		Z MAX		
	C-, M-, P-	Y-, 9-	C- M-	Y- 9-	C-, M-, P-	Y-	
Feedback Option	R, C-, 1-, 2-, Gx	R-, C-, CA 1-, 2-, Gx	R-	R-, C-, CA-, 1-, 2-	C-, 1-, 2-	Gx	Gx
AKM11	56.1 [2.21]	60.8 [2.39]	69.6 [2.74]	79 [3.11]	79 [3.11]	88.5 [3.48]	
AKM12	75.1 [2.96]	79.8 [3.14]	88.6 [3.49]	98 [3.86]	98 [3.86]	107.5 [4.23]	
AKM13	94.1 [3.7]	98.8 [3.89]	107.6 [4.24]	117 [4.61]	117 [4.61]	126.5 [4.98]	

Connector	Brake (2)						
	X			Y MAX		Z MAX	
	C-, M-, P-	C-, M-	Y-, 9-	C-, M-	Y-, 9-	C-, M-, P-	Y-, 9-
Feedback Option	R-, C-, Gx	1-, 2-	R-, C-, CA 1-, 2-, Gx	R-		C-, 1-, 2-, Gx	C-, CA-, 1-, 2-, Gx
AKM11	96.2 [3.79]	98.2 [3.86]	96.2 [3.79]	115.6 [4.55]		125 [4.92]	
AKM12	115.2 [4.54]	117.2 [4.61]	115.2 [4.54]	134.6 [5.3]		144 [5.67]	
AKM13	134.2 [5.28]	136.2 [5.28]	134.2 [5.28]	153.6 [6.05]		163 [6.42]	

Note 1: Dimensions are in mm [inches].

Note 2: Product designed in metric. English conversions provided for reference only.

#### Related Resources:

[Feedback Options and Specifications](#)

[Connector Options and Pinouts](#)

[Brake Option](#)

# AKM2x Series Motor Specifications

## AKM2x Performance Data – Up to 480 Vac (640 Vdc Bus) voltage

Parameters	Tol	Symbol	Units	AKM21			AKM22			AKM23				AKM24			
				C	E	G	C	E	G	C	D	E	F	C	D	E	F
Max Rated Voltage ④	Max	-	Vac	240	120	-	480	240	120	480	480	400	240	480	480	400	240
			Vdc	320	160	75	640	320	160	640	640	560	320	640	640	560	320
Continuous Torque for ΔT winding = 100°C ①②⑦⑧⑨	Nom	T <sub>CS</sub>	Nm	0.48	0.50	0.50	0.84	0.87	0.88	1.13	1.16	1.16	1.18	1.38	1.41	1.40	1.42
			lb-in	4.2	4.4	4.4	7.4	7.7	7.8	10	10.3	10.3	10.4	12.2	12.5	12.4	12.6
Continuous Current for ΔT winding = 100°C ①②⑦⑧⑨	Nom	I <sub>CS</sub>	A <sub>RMS</sub>	1.58	3.11	4.87	1.39	2.73	4.82	1.41	2.19	2.78	4.31	1.42	2.21	2.79	3.89
Continuous Torque for ΔT winding = 60°C ②	Nom	T <sub>CS</sub>	Nm	0.38	0.40	0.40	0.67	0.70	0.70	0.90	0.92	0.93	0.94	1.104	1.13	1.12	1.14
			lb-in	3.4	3.5	3.5	5.9	6.2	6.2	8	8.2	8.23	8.4	9.77	10.0	9.91	10.1
Max Mechanical Speed ⑤	Nom	N <sub>max</sub>	rpm	8000	8000	8000	8000	8000	8000	8000	8000	8000	8000	8000	8000	8000	8000
Peak Torque ①②	Nom	T <sub>p</sub>	Nm	1.47	1.50	1.51	2.73	2.78	2.79	3.81	3.84	3.86	3.89	4.73	4.76	4.79	4.82
			lb-in	13.0	13.3	13.4	24.2	24.6	24.7	33.7	34.0	34.2	34.4	41.9	42.1	42.4	42.7
Peak Current	Nom	I <sub>p</sub>	A <sub>RMS</sub>	6.3	12.5	19.5	5.6	11.0	19.3	5.7	8.8	11.1	17.3	5.7	8.8	11.2	15.6
75 Vdc Rated Torque (speed) ①②⑦⑧⑨⑩		T <sub>rtd</sub>	Nm	-	0.48	0.46	-	0.85	0.83	-	-	-	1.15	-	-	-	1.39
			lb-in	-	4.2	4.1	-	7.5	7.4	-	-	-	10.2	-	-	-	12.3
75 Vdc Rated Speed		N <sub>rtd</sub>	rpm	-	2000	4000	-	1000	2500	-	-	-	1500	-	-	-	1000
75 Vdc Rated Power (speed) ①②⑦⑧⑨		P <sub>rtd</sub>	kW	-	0.10	0.19	-	0.09	0.22	-	-	-	0.18	-	-	-	0.15
			Hp	-	0.13	0.26	-	0.12	0.29	-	-	-	0.24	-	-	-	0.20
120 Vac (160 Vdc) Rated Torque (speed) ①②⑦⑧⑨⑩		T <sub>rtd</sub>	Nm	0.46	0.41	-	0.83	0.81	0.74	1.11	1.12	1.1	1.07	-	1.36	1.34	1.33
			lb-in	4.0	3.7	-	7.3	7.1	6.5	9.8	9.9	9.7	9.5	-	12.0	11.9	11.8
120 Vac (160 Vdc) Rated Speed		N <sub>rtd</sub>	rpm	2500	7000	-	1000	3500	7000	1000	1500	2500	4500	-	1500	2000	3000
120 Vac (160 Vdc) Rated Power (speed) ①②⑦⑧⑨		P <sub>rtd</sub>	kW	0.12	0.30	-	0.09	0.30	0.54	0.12	0.18	0.29	0.50	-	0.21	0.28	0.42
			Hp	0.16	0.41	-	0.12	0.40	0.72	0.16	0.24	0.39	0.68	-	0.29	0.38	0.56
240 Vac (320 Vdc) Rated Torque (speed) ①②⑦⑧⑨⑩		T <sub>rtd</sub>	Nm	0.39	-	-	0.78	.70	-	1.08	1.03	0.98	0.94	1.32	1.29	1.24	1.12
			lb-in	3.4	-	-	6.9	6.2	-	9.6	9.1	8.7	8.3	11.7	11.4	11.0	9.9
240 Vac (320 Vdc) Rated Speed		N <sub>rtd</sub>	rpm	8000	-	-	3500	8000	-	2500	5000	6500	8000	2000	4000	5500	8000
240 Vac (320 Vdc) Rated Power (speed) ①②⑦⑧⑨		P <sub>rtd</sub>	kW	0.32	-	-	0.29	0.59	-	0.28	0.54	0.67	0.79	0.28	0.54	0.71	0.94
			Hp	0.43	-	-	0.38	0.79	-	0.38	0.72	0.89	1.06	0.37	0.72	0.96	1.26
400 Vac (560 Vdc) Rated Torque (speed) ①②⑦⑧⑨⑩		T <sub>rtd</sub>	Nm	-	-	-	0.68	-	-	0.99	0.92	0.87	-	1.25	1.11	0.98	-
			lb-in	-	-	-	6.0	-	-	8.8	8.1	7.7	-	11.1	9.8	8.7	-
400 Vac (560 Vdc) Rated Speed		N <sub>rtd</sub>	rpm	-	-	-	8000	-	-	5500	8000	8000	-	4500	8000	8000	-
400 Vac (560 Vdc) Rated Power (speed) ①②⑦⑧⑨		P <sub>rtd</sub>	kW	-	-	-	0.57	-	-	0.57	0.77	0.73	-	0.59	0.93	0.82	-
			Hp	-	-	-	0.76	-	-	0.76	1.03	0.98	-	0.79	1.25	1.1	-
480 Vac (640 Vdc) Rated Torque (speed) ①②⑦⑧⑨⑩		T <sub>rtd</sub>	Nm	-	-	-	0.68	-	-	0.95	0.92	-	-	1.22	1.11	-	-
			lb-in	-	-	-	6.0	-	-	8.4	8.1	-	-	10.8	9.8	-	-
480 Vac (640 Vdc) Rated Speed		N <sub>rtd</sub>	rpm	-	-	-	8000	-	-	7000	8000	-	-	5500	8000	-	-
480 Vac (640 Vdc) Rated Power (speed) ①②⑦⑧⑨		P <sub>rtd</sub>	kW	-	-	-	0.57	-	-	0.7	0.77	-	-	0.94	0.93	-	-
			Hp	-	-	-	0.76	-	-	0.93	1.03	-	-	0.7	1.25	-	-

See following page for notes.

## AKM2x Motor Parameters

Parameters	Tol	Symbol	Units	AKM21			AKM22			AKM23				AKM24			
				C	E	G	C	E	G	C	D	E	F	C	D	E	F
Torque Constant ①	±10%	K <sub>t</sub>	Nm/A <sub>rms</sub>	0.30	0.16	0.10	0.61	0.32	0.18	0.8	0.52	0.42	0.27	0.97	0.63	0.50	0.36
			lb-in/A <sub>rms</sub>	2.7	1.4	0.9	5.4	2.8	1.6	7.1	4.6	3.7	2.4	8.6	5.6	4.4	3.2
Back EMF Constant ⑥	±10%	K <sub>e</sub>	V <sub>rms</sub> /krpm	19.5	10.2	6.6	39	20.4	11.7	51.8	33.8	27.0	17.6	62.4	40.8	32.5	23.4
Motor Constant	Nom	K <sub>m</sub>	N-m/√W	0.0679	0.0706	0.0680	0.111	0.114	0.110	0.142	0.143	0.147	0.144	0.175	0.171	0.175	0.171
			lb-in/√W	0.601	0.625	0.602	0.986	1.01	0.98	1.26	1.27	1.30	1.28	1.55	1.52	1.55	1.52
Resistance (line-line) ⑥	±10%	R <sub>m</sub>	ohm	13	3.42	1.44	20.0	5.2	1.77	21.2	8.8	5.4	2.34	20.4	9.0	5.4	2.94
Inductance (line-line)		L	mH	19	5.2	2.18	35.5	9.7	3.19	40.7	17.3	11.1	4.68	43.8	18.7	11.8	6.16
Inertia (includes Resolver feedback) ③	±10%	J <sub>m</sub>	kg-cm <sup>2</sup>	0.11			0.16			0.22				0.27			
			lb-in-s <sup>2</sup>	9.5E-05			1.4E-04			1.9E-04				2.4E-04			
Optional Brake Inertia (additional)	±10%	J <sub>m</sub>	kg-cm <sup>2</sup>	0.013			0.013			0.013				0.013			
			lb-in-s <sup>2</sup>	1.2E-05			1.2E-05			1.2E-05				1.2E-05			
Weight (w/o brake) ⑩		W	kg	0.82			1.1			1.38				1.66			
			lb	1.8			2.4			3.0				3.7			
Static Friction ⑩⑩		T <sub>f</sub>	Nm	0.002			0.005			0.007				0.01			
			lb-in	0.02			0.04			0.06				0.09			
Viscous Damping ①		K <sub>dv</sub>	Nm/krpm	0.0046			0.0055			0.0065				0.0074			
			lb-in/krpm	0.04			0.05			0.06				0.07			
Thermal Time Constant		TCT	minutes	8			9			10				11			
Thermal Resistance		R <sub>thw-a</sub>	°C/W	1.43			1.19			1.10				1.07			
Operating Ambient Temperature Range ⑩⑩⑤			°C	-20 to 40			-20 to 40			-20 to 40				-20 to 40			
Pole Pairs				3			3			3				3			
Heat Sink Size				10"x10"x1/4" Aluminum Plate			10"x10"x1/4" Aluminum Plate			10"x10"x1/4" Aluminum Plate				10"x10"x1/4" Aluminum Plate			

Additional windings may exist. Please contact Kollmorgen Customer Support for further information or to request custom winding options for your application requirements.

Notes:

- ① Motor winding temperature rise, ΔT=100°C, at 40°C ambient.
- ② All data referenced to sinusoidal commutation.
- ③ Add parking brake if applicable for total inertia.
- ④ Motor with standard heat sink.
- ⑤ May be limited at some values of V<sub>bus</sub>.
- ⑥ Measured at 25°C.
- ⑦ Brake option reduces continuous torque ratings by:  
AKM21 = 0.00 AKM22 = 0.01 Nm AKM23 = 0.02 Nm AKM24 = 0.05 Nm
- ⑧ For non-resolver feedback options: no continuous torque reduction.
- ⑨ Motors with non-resolver feedback and brake option, reduce continuous torque by:  
AKM21 = 0.00 AKM22 = 0.02 Nm AKM23 = 0.05 Nm AKM24 = 0.12 Nm
- ⑩ For motors with optional shaft seal, reduce torque shown by 0.047 Nm (0.41 lb-in), and increase T<sub>f</sub> by the same amount.
- ⑪ Brake option increases weight by 0.27 kg (0.59 lb).
- ⑫ Motors can be operated up to 480 Vac. For performances curves at voltages, listed or unlisted, please use our online Performance Curve Generator Tool.
- ⑬ Brake option will operate in this range in a non-condensing environment. See the Brake Option section for more information.
- ⑭ "AA" or "AB" BiSS feedback lower limit is -15°C; all other feedbacks meet or exceed this range.
- ⑮ Operation outside of this range may be possible. Please contact Kollmorgen Customer Support with your application requirements.

**Related Resources:**

- [AKM® Servo Motor Quick Guide](#) (for typical torque/speed performance)
- [Performance Curve Generator Tool](#) (generate AKM model specific performance curves)
- [Brake Option](#) (detailed brake specifications)

# AKM2x Series Motor Specifications

## AKM2x Frame Dimensional Drawings

AKM 2D/3D CAD models can be found at [Kollmorgen.com/DesignTools](http://Kollmorgen.com/DesignTools)

### B- connector option

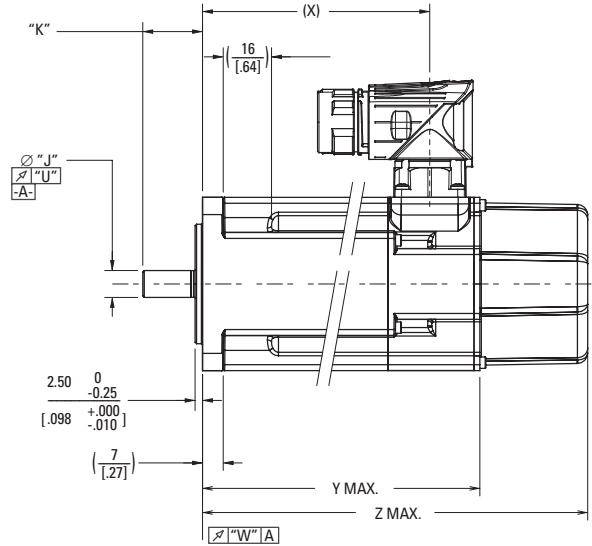
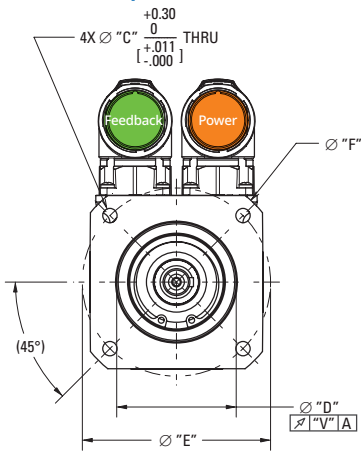

### G- connector option

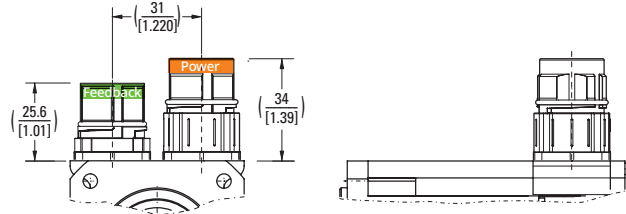
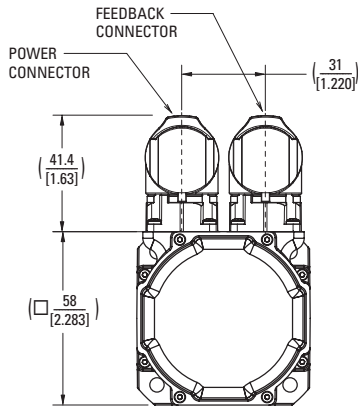

### 9- connector options

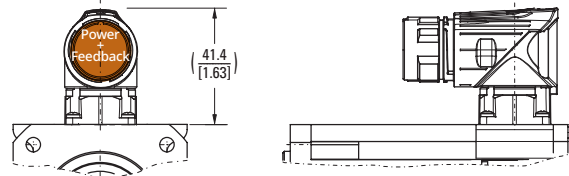

### C-, M-, P- connector options

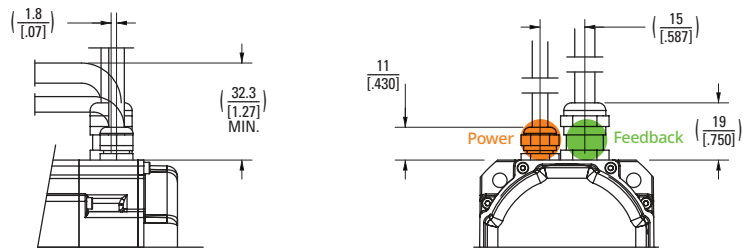

### Shaft-keyway dimensions

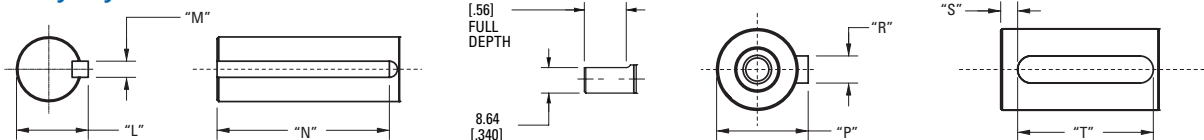

Dimensional data tables for callouts are located on the following page.

## AKM2x Frame Dimensional Data

### AKM2x Mounting Flange-Shaft Dimensional Data

Mounting Flange-Shaft	Hole Diameter "C"	Pilot Diameter "D"	Bolt Circle Dia. "E"	"F"	"H"	Shaft Diameter "J"	Shaft Length "K"	Shaft Dia. w/ Key "L"
AC	4.80 [0.189]	40 [1.5748]	63 [2.480]	74 [2.913]	D M3 DIN 332	9 [0.3543]	20.0 [0.79]	-
AN	4.80 [0.189]	40 [1.5748]	63 [2.480]	74 [2.913]	D M3 DIN 332	9 [0.3543]	20.0 [0.79]	-
BN	5.10 [0.201]	38.10 [1.500]	66.68 [2.625]	-	-	9.525 [0.3750]	31.75 [1.250]	-
CK	5.80 [0.228]	50 [1.9685]	70 [2.756]	-	-	14 [0.5512]	30.0 [1.181]	16 [0.630]
DC	5.80 [0.228]	40 [1.5748]	65 [2.559]	-	D M3 DIN 332	9 [0.3543]	20.0 [0.79]	-
DN	5.80 [0.228]	40 [1.5748]	65 [2.559]	-	D M3 DIN 332	9 [0.3543]	20.0 [0.79]	-
EN & EF	5.10 [0.201]	38.10 [1.500]	66.68 [2.625]	-	-	9.525 [0.3750]	20.57 [0.810]	-

Mounting Flange-Shaft	Key Width "M"	Key Length "N"	Shaft Dia. w/ Key "P"	Key Width "R"	"S"	Key Length "T"	"U"	"V"	"W"
AC	-	-	10.2 [0.402]	3 [0.1181]	300 [0.118]	12 [0.472]	0.030 [0.0011]	0.060 [0.0023]	0.060 [0.0023]
AN	-	-	-	-	-	-	0.030 [0.0011]	0.060 [0.0023]	0.060 [0.0023]
BN	-	-	-	-	-	-	0.051 [0.0020]	0.10 [0.004]	0.10 [0.004]
CK	5 [0.197]	20 [0.787]	-	-	-	-	0.035 [0.0013]	0.080 [0.0031]	0.080 [0.0031]
DC	-	-	10.2 [0.402]	3 [0.1181]	300 [0.118]	12 [0.472]	0.030 [0.0011]	0.060 [0.0023]	0.060 [0.0023]
DN	-	-	-	-	-	-	0.030 [0.0011]	0.060 [0.0023]	0.060 [0.0023]
EN & EF	-	-	-	-	-	-	0.051 [0.0020]	0.10 [0.004]	0.10 [0.004]

### AKM2x Motor Length Dimensional Data

Connector	No Brake (N)					
	X		Y MAX		Z MAX	
	C-, M-, P-	B-, G-, 9-	C-, M-	B-, G-, 9-	C-, M-, P-	B-, G-, 9-
Feedback Option	R, C-, 1-, 2-, Ex, Ax, Dx, Lx	R, C-, 1-, 2-, Cx, Ex, Ax, Dx, Lx, Gx	R-	R, C-, 1-, 2-, Cx, Ex, Ax, Dx, Lx	C-, 1-, 2-, Ex, Ax, Dx, Lx	Gx
AKM21	74.6 [2.94]	76.1 [3]	86.2 [3.39]	95.4 [3.76]	95.4 [3.76]	113.4 [4.46]
AKM22	93.6 [3.69]	95.1 [3.74]	105.2 [4.14]	114.4 [4.5]	114.4 [4.5]	132.4 [5.21]
AKM23	112.6 [4.43]	114.1 [4.49]	124.2 [4.89]	133.4 [5.25]	133.4 [5.25]	151.4 [5.96]
AKM24	131.6 [5.18]	133.1 [5.24]	143.2 [5.64]	152.4 [6]	152.4 [6]	170.4 [6.71]

Connector	Brake (2)				
	X		Z MAX		
	C-, M-, P-	B-, G-, 9-	C-, M-, P-	B-, G-, 9-	B-, G-, 9-
Feedback Option	R, C-, 1-, 2-, Ex, Ax, Dx, Lx	R, C-, 1-, 2-, Cx, Ex, Ax, Dx, Lx, Gx	R, C-, 1-, 2-, Ex, Ax, Dx, Lx	R, C-, 1-, 2-, Cx, Ex, Ax, Dx, Lx	Gx
AKM21	74.6 [2.94]	76.1 [3]	129.5 [5.1]		147.1 [5.79]
AKM22	93.6 [3.69]	95.1 [3.74]	148.5 [5.85]		166.1 [6.54]
AKM23	112.6 [4.43]	114.1 [4.49]	167.5 [6.59]		185.1 [7.29]
AKM24	131.6 [5.18]	133.1 [5.24]	186.5 [7.34]		204.1 [8.04]

Note 1: Dimensions are in mm [inches].

Note 2: Product designed in metric. English conversions provided for reference only.

#### Related Resources:

[Feedback Options and Specifications](#)

[Connector Options and Pinouts](#)

[Brake Option](#)

# AKM3x Series Motor Specifications

## AKM3x Performance Data – Up to 480 Vac (640 Vdc Bus) voltage

Parameters	Tol	Symbol	Units	AKM31			AKM32				AKM33		
				C	E	H	C	D	E	H	C	E	H
Max Rated Voltage ⑥	Max	-	Vac	480	240	120	480	480	480	240	480	480	240
			Vdc	640	320	160	640	640	640	320	640	640	320
Continuous Torque for ΔT winding = 100°C ①②⑦⑧⑨	Nom	T <sub>CS</sub>	Nm	1.15	1.20	1.23	2.00	2.04	2.04	2.10	2.71	2.79	2.88
			lb-in	10.2	10.6	10.8	17.7	18.1	18.1	18.6	24.0	24.7	25.5
Continuous Current for ΔT winding = 100°C ①②⑦⑧⑨	Nom	I <sub>CS</sub>	A <sub>RMS</sub>	1.37	2.99	5.85	1.44	2.23	2.82	5.50	1.47	2.58	5.62
Continuous Torque for ΔT winding = 60°C ②	Nom	T <sub>CS</sub>	Nm	0.92	0.96	0.98	1.60	1.63	1.63	1.68	2.17	2.23	2.30
			lb-in	8.1	8.5	8.7	14.2	14.4	14.4	14.9	19.2	19.7	20.4
Max Mechanical Speed ⑤	Nom	N <sub>max</sub>	rpm	8000	8000	8000	8000	8000	8000	8000	8000	8000	
Peak Torque ①②	Nom	T <sub>p</sub>	Nm	3.88	4.00	4.06	6.92	7.10	7.11	7.26	9.76	10.0	10.2
			lb-in	34.3	35.4	35.9	61.2	62.8	62.9	64.3	86.4	88.1	90.4
Peak Current	Nom	I <sub>p</sub>	A <sub>RMS</sub>	5.5	12.0	23.4	5.7	8.9	11.3	22.0	5.9	10.3	22.5
75 Vdc Rated Torque (speed) ①②⑦⑧⑨⑩		T <sub>rtd</sub>	Nm	-	1.19	1.20	-	-	-	2.06	-	-	2.82
			lb-in	-	10.5	10.6	-	-	-	18.2	-	-	24.6
Rated Speed		N <sub>rtd</sub>	rpm	-	750	2000	-	-	-	1200	-	-	800
Rated Power (speed) ①②⑦⑧⑨		P <sub>rtd</sub>	kW	-	0.09	0.25	-	-	-	0.26	-	-	0.24
			Hp	-	0.13	0.34	-	-	-	0.35	-	-	0.32
120 Vac (160 Vdc) Rated Torque (speed) ①②⑦⑧⑨⑩		T <sub>rtd</sub>	Nm	-	1.17	0.97	-	2.00	2.01	1.96	-	-	2.66
			lb-in	-	10.3	8.6	-	17.7	17.7	17.4	-	-	23.5
Rated Speed		N <sub>rtd</sub>	rpm	-	2500	6000	-	1000	1000	3000	-	-	2500
Rated Power (speed) ①②⑦⑧⑨		P <sub>rtd</sub>	kW	-	0.31	0.61	-	0.21	0.21	0.62	-	-	0.70
			Hp	-	0.41	0.82	-	0.28	0.28	0.83	-	-	0.93
240 Vac (320 Vdc) Rated Torque (speed) ①②⑦⑧⑨⑩		T <sub>rtd</sub>	Nm	1.12	0.95	-	1.95	1.93	1.87	1.45	2.64	2.62	2.27
			lb-in	9.9	8.4	-	17.3	17.1	16.5	12.8	23.4	23.2	20.1
Rated Speed		N <sub>rtd</sub>	rpm	2500	6000	-	1500	2500	3500	7000	1000	2000	5500
Rated Power (speed) ①②⑦⑧⑨		P <sub>rtd</sub>	kW	0.29	0.60	-	0.31	0.51	0.69	1.06	0.28	0.55	1.31
			Hp	0.39	0.80	-	0.41	0.68	0.93	1.42	0.37	0.74	1.75
400 Vac (560 Vdc) Rated Torque (speed) ①②⑦⑧⑨⑩		T <sub>rtd</sub>	Nm	1.00	-	-	1.86	1.65	1.41	-	2.54	2.34	-
			lb-in	8.9	-	-	16.5	14.6	12.5	-	22.5	20.7	-
Rated Speed		N <sub>rtd</sub>	rpm	5000	-	-	3000	5500	7000	-	2000	4500	-
Rated Power (speed) ①②⑦⑧⑨		P <sub>rtd</sub>	kW	0.52	-	-	0.58	0.95	1.03	-	0.53	1.10	-
			Hp	0.70	-	-	0.78	1.27	1.38	-	0.71	1.48	-
480 Vac (640 Vdc) Rated Torque (speed) ①②⑦⑧⑨⑩		T <sub>rtd</sub>	Nm	0.91	-	-	1.83	1.58	1.22	-	2.50	2.27	-
			lb-in	8.1	-	-	16.2	14.0	10.8	-	22.1	20.1	-
Rated Speed		N <sub>rtd</sub>	rpm	6000	-	-	3500	6000	8000	-	2500	5000	-
Rated Power (speed) ①②⑦⑧⑨		P <sub>rtd</sub>	kW	0.57	-	-	0.67	0.99	1.02	-	0.65	1.19	-
			Hp	0.77	-	-	0.90	1.33	1.37	-	0.88	1.59	-

See following page for notes.

## AKM3x Motor Parameters

Parameters	Tol	Symbol	Units	AKM31			AKM32				AKM33		
				C	E	H	C	D	E	H	C	E	H
Torque Constant ①	±10%	$K_t$	Nm/A <sub>rms</sub>	0.85	0.41	0.21	1.40	0.92	0.73	0.39	1.86	1.10	0.52
			lb-in/A <sub>rms</sub>	7.5	3.6	1.9	12.4	8.1	6.5	3.5	16.5	9.7	4.6
Back EMF Constant ②	±10%	$K_e$	V <sub>rms</sub> /krpm	54.5	26.1	13.7	89.8	59.0	47.1	24.8	120	70.6	33.4
Motor Constant	Nom	$K_m$	N-m/√W	0.150	0.154	0.151	0.235	0.232	0.237	0.245	0.295	0.299	0.303
			lb-in/√W	1.33	1.36	1.34	2.08	2.05	2.10	2.17	2.61	2.65	2.68
Resistance (line-line) ③	±10%	$R_m$	ohm	21.4	4.74	1.29	23.8	9.7	6.3	1.69	26.6	9.0	1.96
Inductance (line-line)		L	mH	37.5	8.6	2.4	46.5	20.1	12.8	3.5	53.6	18.5	4.1
Inertia (includes Resolver feedback) ③	±10%	$J_m$	kg-cm <sup>2</sup>	0.33			0.59				0.85		
			lb-in-s <sup>2</sup>	2.9E-04			5.2E-04				7.5E-04		
Optional Brake Inertia (additional)	±10%	$J_m$	kg-cm <sup>2</sup>	0.014			0.014				0.014		
			lb-in-s <sup>2</sup>	1.2E-05			1.2E-05				1.2E-05		
Weight (w/o brake) ④		W	kg	1.55			2.23				2.9		
			lb	3.4			4.9				6.4		
Static Friction ①⑩		$T_f$	Nm	0.014			0.02				0.026		
			lb-in	0.12			0.18				0.23		
Viscous Damping ①		$K_{dv}$	Nm/krpm	0.002			0.003				0.004		
			lb-in/krpm	0.02			0.03				0.04		
Thermal Time Constant		TCT	minutes	14			17				20		
Thermal Resistance		$R_{thw-a}$	°C/W	1.11			0.92				0.78		
Operating Ambient Temperature Range ⑤ ④ ⑤			°C	-20 to 40			-20 to 40				-20 to 40		
Pole Pairs				4			4				4		
Heat Sink Size				10"x10"x1/4" Aluminum Plate			10"x10"x1/4" Aluminum Plate				10"x10"x1/4" Aluminum Plate		

Additional windings may exist. Please contact Kollmorgen Customer Support for further information or to request custom winding options for your application requirements.

### Notes:

- ① Motor winding temperature rise, ΔT=100°C, at 40°C ambient.
- ② All data referenced to sinusoidal commutation.
- ③ Add parking brake if applicable for total inertia.
- ④ Motor with standard heat sink.
- ⑤ May be limited at some values of V<sub>bus</sub>.
- ⑥ Measured at 25°C.
- ⑦ Brake option reduces continuous torque ratings by:  
AKM31 = 0.0 Nm    AKM32 = 0.05 Nm    AKM33 = 0.1 Nm
- ⑧ For non-resolver feedback options: no continuous torque reduction.
- ⑨ Motors with non-resolver feedback and brake option, reduce continuous torque by:  
AKM31 = 0.0 Nm    AKM32 = 0.1 Nm    AKM33 = 0.2 Nm
- ⑩ For motors with optional shaft seal, reduce torque shown by 0.047 Nm (0.41 lb-in), and increase T<sub>f</sub> by the same amount.
- ⑪ Brake option increases weight by 0.36 kg (0.79 lb).
- ⑫ Motors can be operated up to 480 Vac. For performance curves at voltages, listed or unlisted, please use our online Performance Curve Generator Tool.
- ⑬ Brake option will operate in this range in a non-condensing environment. See the Brake Option section for more information.
- ⑭ "AA" or "AB" BiSS feedback lower limit is -15°C; all other feedbacks meet or exceed this range.

### Related Resources:

- [AKM® Servo Motor Quick Guide](#) (for typical torque/speed performance)
- [Performance Curve Generator Tool](#) (generate AKM model specific performance curves)
- [Brake Option](#) (detailed brake specifications)

# AKM3x Series Motor Specifications

## AKM3x Frame Dimensional Drawings

AKM 2D/3D CAD models can be found at [Kollmorgen.com/DesignTools](http://Kollmorgen.com/DesignTools)

### C- connector option

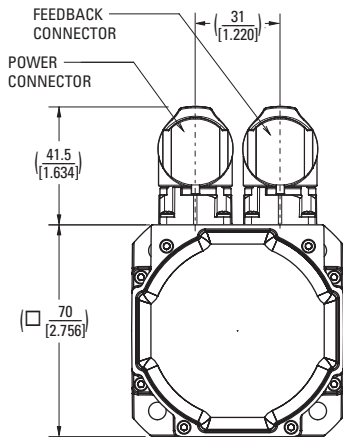
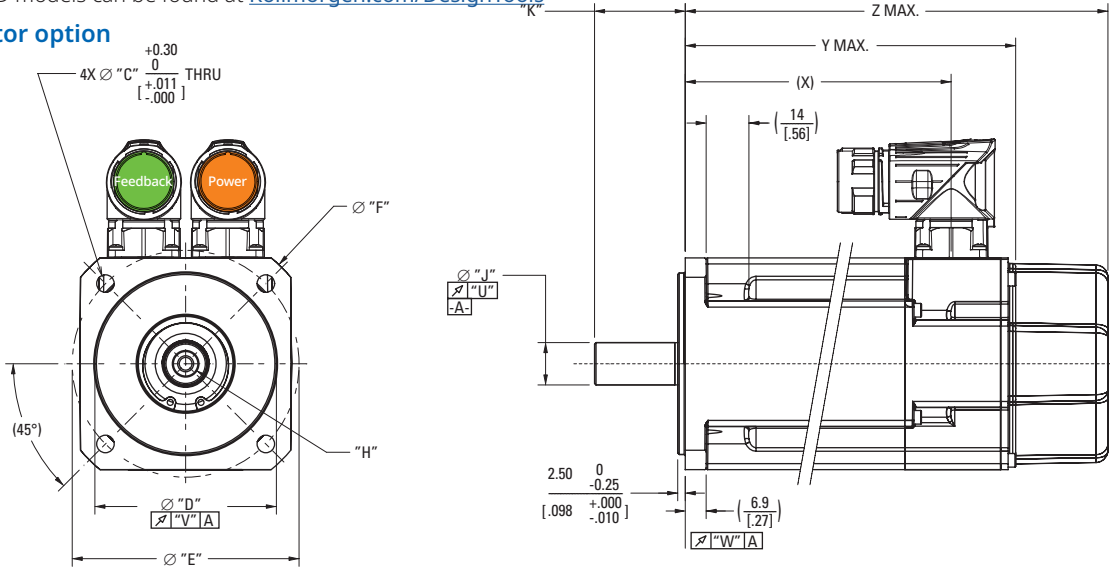

### G- connector option

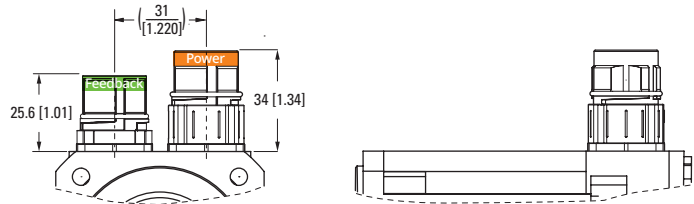

### 9- connector option

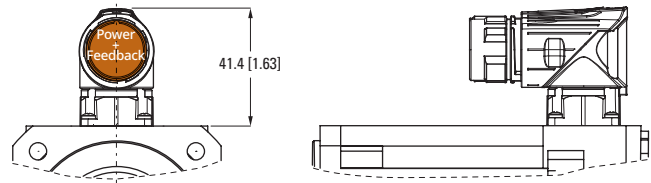

### M-, P- connector options

- AKM31 (94.6 [3.72])
- AKM32 (125.6 [4.94])
- AKM33 (156.6 [6.17])

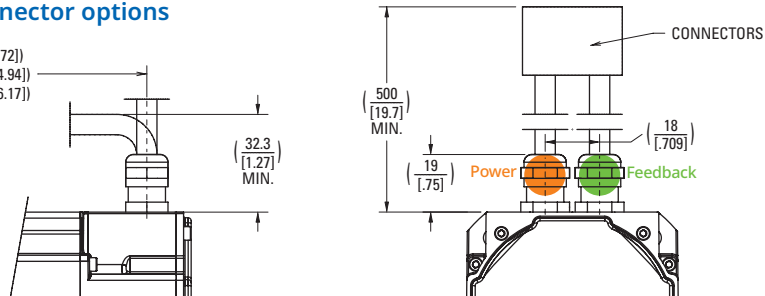

### Shaft-keyway dimensions

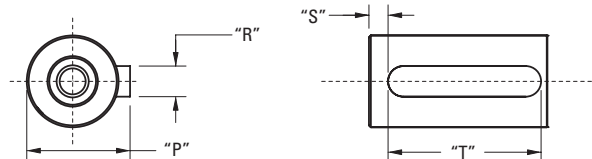

Dimensional data tables for callouts are located on the following page.

## AKM3x Frame Dimensional Data

### AKM3x Mounting Flange-Shaft Dimensional Data

Mounting Flange-Shaft	Hole Diameter "C"	Pilot Diameter "D"	Bolt Circle Dia. "E"	"F"	"H"	Shaft Diameter "J"	Shaft Length "K"	Shaft Dia. w/ Key "P"
AC	5.80 [0.228]	60 [2.3622]	75 [2.953]	90 [3.543]	D M5 DIN 332	14 [0.5512]	30.0 [1.181]	16 [0.630]
AN	5.80 [0.228]	60 [2.3622]	75 [2.953]	90 [3.543]	D M5 DIN 332	14 [0.5512]	30.0 [1.181]	-
CC	5.80 [0.228]	60 [2.3622]	85 [3.346]	-	D M5 DIN 332	14 [0.5512]	30.0 [1.181]	16 [0.630]
CN	5.80 [0.228]	60 [2.3622]	85 [3.346]	-	D M5 DIN 332	14 [0.5512]	30.0 [1.181]	-
GC	5.80 [0.228]	60 [2.3622]	75 [2.953]	90 [3.543]	D M5 DIN 332	11[0.4331]	23 [0.906]	12.5 [0.492]
GN	5.80 [0.228]	60 [2.3622]	75 [2.953]	90 [3.543]	D M5 DIN 332	11 [0.4331]	23 [0.906]	-

Mounting Flange-Shaft	Key Width "R"	"S"	Key Length "T"	"U"	"V"	"W"
AC	5 [0.197]	5.00 [1.97]	20 [0.787]	0.035 [0.0013]	0.080 [0.0031]	0.080 [0.0031]
AN	-	-	-	0.035 [0.0013]	0.080 [0.0031]	0.080 [0.0031]
CC	5 [0.197]	5.00 [1.97]	20 [0.787]	0.035 [0.0013]	0.080 [0.0031]	0.080 [0.0031]
CN	-	-	-	0.035 [0.0013]	0.080 [0.0031]	0.080 [0.0031]
GC	4 [0.157]	3.5 [0.138]	16 [0.630]	0.035 [0.0013]	0.080 [0.0031]	0.080 [0.0031]
GN	-	-	-	0.035 [0.0013]	0.080 [0.0031]	0.080 [0.0031]

### AKM3x Motor Length Dimensional Data

Connector	No Brake (N)		
	X*	Y MAX	Z MAX
	C-, 9-, G-, M-, P-	C-, 9-, G-, M-, P-	C-, 9-, G-
Feedback Option	R-, C-, 1-, 2-, Cx, Ex, Ax, Dx, Lx, Gx	R-, C-, 1-, 2-, Cx, Ex, Ax, Dx, Lx	Gx
AKM31	87.9 [3.46]	109.8 [4.32]	125.3 [4.93]
AKM32	118.9 [4.68]	140.8 [5.54]	156.3 [6.15]
AKM33	149.9 [5.9]	171.8 [6.76]	187.3 [7.37]

Connector	Brake (2)		
	X*	Z MAX	
	C-, 9-, G-, M-, P-	C-, 9-, G-, M-, P-	C-, 9-, G-
Feedback Option	R-, C-, 1-, 2-, Cx, Ex, Ax, Dx, Lx, Gx	R-, C-, 1-, 2-, Cx, Ex, Ax, Dx, Lx	Gx
AKM31	87.9 [3.46]	141.3 [5.56]	159.3 [6.27]
AKM32	118.9 [4.68]	172.3 [6.78]	190.3 [7.49]
AKM33	149.9 [5.9]	203.3 [8]	221.3 [8.71]

\*For 0.5m shielded cable option (M or P), add 6.7 mm to "X"

Note 1: Dimensions are in mm [inches].

Note 2: Product designed in metric. English conversions provided for reference only.

#### Related Resources:

[Feedback Options and Specifications](#)

[Connector Options and Pinouts](#)

[Brake Option](#)

# AKM4x Series Motor Specifications

## AKM41-42 Performance Data – Up to 480 Vac (640 Vdc Bus) voltage

Parameters	Tol	Sym	Units	AKM41			AKM42				
				C	E	H	C	E	G	H	J
Max Rated Voltage ⑩	Max	-	Vac	480	480	240	480	480	480	240	240
			Vdc	640	640	320	640	640	640	320	320
Continuous Torque for ΔT winding = 100°C ①②⑦⑧⑨	Nom	T <sub>CS</sub>	Nm	1.95	2.02	2.06	3.35	3.42	3.53	3.54	3.56
			lb-in	17.3	17.9	18.2	29.6	30.3	31.2	31.3	31.5
Continuous Current for ΔT winding = 100°C ①②⑦⑧⑨	Nom	I <sub>CS</sub>	A <sub>rms</sub>	1.46	2.85	5.60	1.40	2.74	4.8	5.9	8.4
Continuous Torque for ΔT winding = 60°C ②	Nom	T <sub>CS</sub>	Nm	1.56	1.62	1.65	2.68	2.74	2.82	2.83	2.85
			lb-in	13.8	14.3	14.6	23.7	24.2	25	25	25.2
Max Mechanical Speed ⑤	Nom	N <sub>max</sub>	rpm	6000	6000	6000	6000	6000	6000	6000	
Peak Torque ①②	Nom	T <sub>p</sub>	Nm	6.1	6.3	6.4	11.1	11.3	11.5	11.6	11.6
			lb-in	54.2	55.6	56.3	98.2	99.7	102	103	103
Peak Current	Nom	I <sub>p</sub>	A <sub>rms</sub>	5.8	11.4	22.4	5.60	11.0	19.2	24.0	33.7
75 Vdc Rated Torque (speed) ①②⑦⑧⑨⑩		T <sub>Rtd</sub>	Nm	-	-	1.99	-	-	-	-	-
			lb-in	-	-	17.6	-	-	-	-	-
Rated Speed		N <sub>Rtd</sub>	rpm	-	-	1000	-	-	-	-	
Rated Power (speed) ①②⑦⑧⑨		P <sub>Rtd</sub>	kW	-	-	0.21	-	-	-	-	-
			Hp	-	-	0.28	-	-	-	-	-
120 Vac (160 Vdc) Rated Torque (speed) ①②⑦⑧⑨⑩		T <sub>Rtd</sub>	Nm	-	1.94	1.86	-	-	-	3.2	3.03
			lb-in	-	17.2	16.5	-	-	-	28.3	26.8
Rated Speed		N <sub>Rtd</sub>	rpm	-	1200	3000	-	-	-	2000	3000
Rated Power (speed) ①②⑦⑧⑨		P <sub>Rtd</sub>	kW	-	0.24	0.58	-	-	-	0.67	0.95
			Hp	-	0.33	0.78	-	-	-	0.9	1.28
240 Vac (320 Vdc) Rated Torque (speed) ①②⑦⑧⑨⑩		T <sub>Rtd</sub>	Nm	1.88	1.82	1.62	-	3.12	2.90	2.72	2.38
			lb-in	16.6	16.1	14.3	-	27.6	25.7	24.1	21.1
Rated Speed		N <sub>Rtd</sub>	rpm	1200	3000	6000	-	1800	3500	4500	6000
Rated Power (speed) ①②⑦⑧⑨		P <sub>Rtd</sub>	kW	0.24	0.57	1.02	-	0.59	1.06	1.28	1.50
			Hp	0.32	0.77	1.36	-	0.79	1.42	1.72	2.00
400 Vac (560 Vdc) Rated Torque (speed) ①②⑦⑧⑨⑩		T <sub>Rtd</sub>	Nm	1.77	1.58	-	3.10	2.81	2.35	-	-
			lb-in	15.7	14.0	-	27.4	24.9	20.8	-	-
Rated Speed		N <sub>Rtd</sub>	rpm	3000	6000	-	1500	3500	6000	-	-
Rated Power (speed) ①②⑦⑧⑨		P <sub>Rtd</sub>	kW	0.56	0.99	-	0.49	1.03	1.48	-	-
			Hp	0.75	1.33	-	0.65	1.38	1.98	-	-
480 Vac (640 Vdc) Rated Torque (speed) ①②⑦⑧⑨⑩		T <sub>Rtd</sub>	Nm	1.74	1.58	-	3.02	2.72	2.35	-	-
			lb-in	15.4	14.0	-	26.7	24.1	20.8	-	-
Rated Speed		N <sub>Rtd</sub>	rpm	3500	6000	-	2000	4000	6000	-	-
Rated Power (speed) ①②⑦⑧⑨		P <sub>Rtd</sub>	kW	0.64	0.99	-	0.63	1.14	1.48	-	-
			Hp	0.85	1.33	-	0.85	1.53	1.98	-	-

See following page for notes.

## AKM41-42 Motor Parameters

Parameters	Tol	Sym	Units	AKM41			AKM42				
				C	E	H	C	E	G	H	J
Torque Constant ①	±10%	K <sub>t</sub>	Nm/A <sub>rms</sub>	1.34	0.71	0.37	2.39	1.26	0.74	0.59	0.43
			lb-in/A <sub>rms</sub>	11.9	6.3	3.3	21.2	11.2	6.5	5.2	3.8
Back EMF Constant ⑥	±10%	K <sub>e</sub>	V <sub>rms</sub> /krpm	86.3	45.6	23.7	154	80.9	47.5	38.3	27.5
Motor Constant	Nom	K <sub>m</sub>	N-m/√W	0.237	0.236	0.242	0.374	0.369	0.381	0.375	0.393
			lb-in/√W	2.10	2.09	2.14	3.31	3.26	3.37	3.31	3.47
Resistance (line-line) ⑥	±10%	R <sub>m</sub>	ohm	21.3	6.0	1.56	27.5	7.5	2.51	1.65	0.8
Inductance (line-line)		L	mH	66.1	18.4	5.0	97.4	26.8	9.2	6	3.1
Inertia (includes Resolver feedback) ③	±10%	J <sub>m</sub>	kg-cm <sup>2</sup>	0.81			1.5				
			lb-in-s <sup>2</sup>	7.2E-04			1.3E-03				
Optional Brake Inertia (additional)	±10%	J <sub>m</sub>	kg-cm <sup>2</sup>	0.058			0.058				
			lb-in-s <sup>2</sup>	5.1E-05			5.1E-05				
Weight (w/o brake) ⑩		W	kg	2.44			3.39				
			lb	5.4			7.5				
Static Friction ①⑩		T <sub>f</sub>	Nm	0.014			0.026				
			lb-in	0.12			0.23				
Viscous Damping ①		K <sub>dv</sub>	Nm/krpm	0.009			0.013				
			lb-in/krpm	0.08			0.12				
Thermal Time Constant		TCT	minutes	13			17				
Thermal Resistance		R <sub>thw-a</sub>	°C/W	0.97			0.80				
Operating Ambient Temperature Range ⑩⑪⑫			°C	-20 to 40			-20 to 40				
Pole Pairs				5			5				
Heat Sink Size				10"x10"x1/4" Aluminum Plate			10"x10"x1/4" Aluminum Plate				

Additional windings may exist. Please contact Kollmorgen Customer Support for further information or to request custom winding options for your application requirements.

**Notes:**

- ① Motor winding temperature rise, ΔT=100°C, at 40°C ambient.
- ② All data referenced to sinusoidal commutation.
- ③ Add parking brake if applicable for total inertia.
- ④ Motor with standard heat sink.
- ⑤ May be limited at some values of V<sub>bus</sub>.
- ⑥ Measured at 25°C.
- ⑦ Brake motor option reduces continuous torque ratings by 0.12 Nm.
- ⑧ Non-Resolver feedback options reduces continuous ratings by:  
AKM41 = 0.1 Nm   AKM42 = 0.1 Nm   AKM43 = 0.2 Nm   AKM44 = 0.3 Nm
- ⑨ Motors with non-resolver feedback and brake option, reduce continuous torque by:  
AKM41 = 0.22 Nm   AKM42 = 0.36 Nm   AKM43 = 0.55 Nm   AKM44 = 0.76 Nm
- ⑩ For motors with optional shaft seal, reduce torque shown by 0.071 Nm (0.63 lb-in), and increase T<sub>f</sub> by the same amount.
- ⑪ Brake option increases weight by 0.69 kg (1.52 lb).
- ⑫ Motors can be operated up to 480 Vac. For performances curves at voltages, listed or unlisted, please use our online Performance Curve Generator Tool.
- ⑬ Brake option will operate in this range in a non-condensing environment. See the Brake Option section for more information.
- ⑭ "AA" or "AB" BiSS feedback lower limit is -15°C; all other feedbacks meet or exceed this range.
- ⑮ Operation outside of this range may be possible. Please contact Kollmorgen Customer Support with your application requirements.
- ⑯ High speed continuous performance could be reduced by additional losses due to combination of source voltage, winding inductance, and servo drive PWM frequency. Please contact Kollmorgen Customer Support with your specific applications requirements.

**Related Resources:**

- [AKM® Servo Motor Quick Guide](#) (for typical torque/speed performance)
- [Performance Curve Generator Tool](#) (generate AKM model specific performance curves)
- [Brake Option](#) (detailed brake specifications)

# AKM4x Series Motor Specifications

## AKM43-44 Performance Data – Up to 480 Vac (640 Vdc Bus) voltage

Parameters	Tol	Sym	Units	AKM43					AKM44				
				E	G	H	K	L	E	G	H	J	K
Max Rated Voltage ⑩	Max	-	Vac	480	480	400	240	240	480	480	480	480	240
			Vdc	640	640	560	320	320	640	640	640	640	320
Continuous Torque for $\Delta T$ winding = 100°C ①②⑦⑧⑨	Nom	$T_{cs}$	Nm	4.70	4.80	4.82	4.90	4.73	5.76	5.88	5.89	6.00	5.88
			lb-in	41.6	42.5	42.7	43.4	41.9	51.0	52	52.1	53.1	52
Continuous Current for $\Delta T$ winding = 100°C ①②⑦⑧⑨	Nom	$I_{cs}$	$A_{rms}$	2.76	4.87	5.4	9.6	11.2	2.9	5.0	5.6	8.8	10.1
Continuous Torque for $\Delta T$ winding = 60°C ②	Nom	$T_{cs}$	Nm	3.76	3.84	3.86	3.92	3.78	4.61	4.7	4.71	4.80	4.7
			lb-in	33.3	34	34.2	34.7	33.5	40.8	41.6	41.7	42.5	41.6
Max Mechanical Speed ⑥	Nom	$N_{max}$	rpm	6000	6000	6000	6000	6000	6000	6000	6000	6000	6000
Peak Torque ①②	Nom	$T_p$	Nm	15.9	16.1	16.1	16.4	16.0	19.9	23.3	20.2	20.5	20.2
			lb-in	141	142	142	145	142	176	180	179	181	179
Peak Current	Nom	$I_p$	$A_{rms}$	11.0	19.5	21.6	38.4	44.6	11.4	20.0	22.4	35.2	40.4
75 Vdc Rated Torque (speed) ①②⑦⑧⑨⑩		$T_{rtd}$	Nm	-	-	-	-	-	-	-	-	-	-
			lb-in	-	-	-	-	-	-	-	-	-	-
Rated Speed		$N_{rtd}$	rpm	-	-	-	-	-	-	-	-	-	-
Rated Power (speed) ①②⑦⑧⑨		$P_{rtd}$	kW	-	-	-	-	-	-	-	-	-	-
			Hp	-	-	-	-	-	-	-	-	-	-
120 Vac (160 Vdc) Rated Torque (speed) ①②⑦⑧⑨⑩		$T_{rtd}$	Nm	-	-	-	4.08	3.78	-	-	-	-	4.9
			lb-in	-	-	-	36.1	33.5	-	-	-	-	43.4
Rated Speed		$N_{rtd}$	rpm	-	-	-	2500	3000	-	-	-	-	2000
Rated Power (speed) ①②⑦⑧⑨		$P_{rtd}$	kW	-	-	-	1.07	1.19	-	-	-	-	1.38
			Hp	-	-	-	1.43	1.59	-	-	-	-	1.03
240 Vac (320 Vdc) Rated Torque (speed) ①②⑦⑧⑨⑩		$T_{rtd}$	Nm	4.24	4	3.86	2.62	2.53	5.22	4.9	4.66	3.84	3.18
			lb-in	37.5	35.4	34.2	23.2	22.4	46.2	43.4	41.2	34.0	28.1
Rated Speed		$N_{rtd}$	rpm	1500	2500	3000	6000	6000	1200	2000	2500	4000	5000
Rated Power (speed) ①②⑦⑧⑨		$P_{rtd}$	kW	0.67	1.05	1.21	1.65	1.59	0.66	1.03	1.22	1.61	1.67
			Hp	0.89	1.4	1.63	2.21	2.13	0.88	1.38	1.64	2.16	2.23
400 Vac (560 Vdc) Rated Torque (speed) ①②⑦⑧⑨⑩		$T_{rtd}$	Nm	3.92	3.01	2.81	-	-	4.80	3.76	3.19	2.75	-
			lb-in	34.7	26.6	24.9	-	-	42.5	33.3	28.2	24.3	-
Rated Speed		$N_{rtd}$	rpm	2500	5000	5500	-	-	2000	4000	5000	6000	-
Rated Power (speed) ①②⑦⑧⑨		$P_{rtd}$	kW	1.03	1.58	1.62	-	-	1.01	1.57	1.67	1.73	-
			Hp	1.38	2.11	2.17	-	-	1.35	2.11	2.24	2.32	-
480 Vac (640 Vdc) Rated Torque (speed) ①②⑦⑧⑨⑩		$T_{rtd}$	Nm	3.76	2.57	-	-	-	4.56	3.19	2.7	2.75⑩	-
			lb-in	33.3	22.7	-	-	-	40.4	28.2	23.9	24.3⑩	-
Rated Speed		$N_{rtd}$	rpm	3000	6000	-	-	-	2500	5000	6000	6000⑩	-
Rated Power (speed) ①②⑦⑧⑨		$P_{rtd}$	kW	1.18	1.61	-	-	-	1.19	1.67	1.70	1.73⑩	-
			Hp	1.58	2.16	-	-	-	1.60	2.24	2.28	2.32⑩	-

See following page for notes.

## AKM43-44 Motor Parameters

Parameters	Tol	Sym	Units	AKM43					AKM44				
				E	G	H	K	L	E	G	H	J	K
Torque Constant ①	±10%	$K_t$	Nm/A <sub>rms</sub>	1.72	0.99	0.89	0.52	0.43	2.04	1.20	1.06	0.69	0.59
			lb-in/A <sub>rms</sub>	15.2	8.8	7.9	4.6	3.8	18.1	10.6	9.4	6.1	5.2
Back EMF Constant ⑥	±10%	$K_e$	V <sub>rms</sub> /krpm	111	63.9	57.4	33.2	27.5	132	77	68	44.2	37.8
Motor Constant	Nom	$K_m$	N-m/√W	0.479	0.482	0.501	0.494	0.465	0.567	0.567	0.580	0.581	0.567
			lb-in/√W	4.24	4.29	4.44	4.37	4.12	5.01	5.03	5.13	5.14	5.10
Resistance (line-line) ⑥	±10%	$R_m$	ohm	8.61	2.81	2.20	0.74	0.57	8.64	2.80	2.23	0.94	0.68
Inductance (line-line)		L	mH	32.6	10.8	8.8	2.90	2.00	33.9	11.5	9.1	3.8	2.8
Inertia (includes Resolver feedback) ③	±10%	$J_m$	kg-cm <sup>2</sup>	2.1					2.7				
			lb-in-s <sup>2</sup>	1.8E-03					2.4E-03				
Optional Brake Inertia (additional)	±10%	$J_m$	kg-cm <sup>2</sup>	0.058					0.058				
			lb-in-s <sup>2</sup>	5.1E-05					5.1E-05				
Weight (w/o brake) ⑩		W	kg	4.35					5.3				
			lb	9.6					11.7				
Static Friction ⑩⑩		$T_f$	Nm	0.038					0.05				
			lb-in	0.34					0.44				
Viscous Damping ①		$K_{dv}$	Nm/krpm	0.017					0.021				
			lb-in/krpm	0.15					0.19				
Thermal Time Constant		TCT	minutes	20					24				
Thermal Resistance		$R_{thw-a}$	°C/W	0.70					0.65				
Operating Ambient Temperature Range ⑩ ⑭ ⑮			°C	-20 to 40					-20 to 40				
Pole Pairs				5					5				
Heat Sink Size				10"x10"x1/4" Aluminum Plate					10"x10"x1/4" Aluminum Plate				

Additional windings may exist. Please contact Kollmorgen Customer Support for further information or to request custom winding options for your application requirements.

Notes:

- ① Motor winding temperature rise,  $\Delta T=100^\circ\text{C}$ , at  $40^\circ\text{C}$  ambient.
- ② All data referenced to sinusoidal commutation.
- ③ Add parking brake if applicable for total inertia.
- ④ Motor with standard heat sink.
- ⑤ May be limited at some values of  $V_{bus}$ .
- ⑥ Measured at  $25^\circ\text{C}$ .
- ⑦ Brake motor option reduces continuous torque ratings by 0.12 Nm.
- ⑧ Non-Resolver feedback options reduces continuous ratings by:  
AKM41 = 0.1 Nm   AKM42 = 0.1 Nm   AKM43 = 0.2 Nm   AKM44 = 0.3 Nm
- ⑨ Motors with non-resolver feedback and brake option, reduce continuous torque by:  
AKM41 = 0.22 Nm   AKM42 = 0.36 Nm   AKM43 = 0.55 Nm   AKM44 = 0.76 Nm
- ⑩ For motors with optional shaft seal, reduce torque shown by 0.071 Nm (0.63 lb-in), and increase  $T_f$  by the same amount.
- ⑪ Brake option increases weight by 0.69 kg (1.52 lb).
- ⑫ Motors can be operated up to 480 Vac. For performances curves at voltages, listed or unlisted, please use our online Performance Curve Generator Tool.
- ⑬ Brake option will operate in this range in a non-condensing environment. See the Brake Option section for more information.
- ⑭ "AA" or "AB" BiSS feedback lower limit is  $-15^\circ\text{C}$ ; all other feedbacks meet or exceed this range.
- ⑮ Operation outside of this range may be possible. Please contact Kollmorgen Customer Support with your application requirements.
- ⑯ High speed continuous performance could be reduced by additional losses due to combination of source voltage, winding inductance, and servo drive PWM frequency. Please contact Kollmorgen Customer Support with your specific applications requirements.

### Related Resources:

- [AKM® Servo Motor Quick Guide](#) (for typical torque/speed performance)
- [Performance Curve Generator Tool](#) (generate AKM model specific performance curves)
- [Brake Option](#) (detailed brake specifications)

# AKM4x Series Motor Specifications

## AKM4x Frame Dimensional Drawings

AKM 2D/3D CAD models can be found at [Kollmorgen.com/DesignTools](http://Kollmorgen.com/DesignTools)

### C- connector option

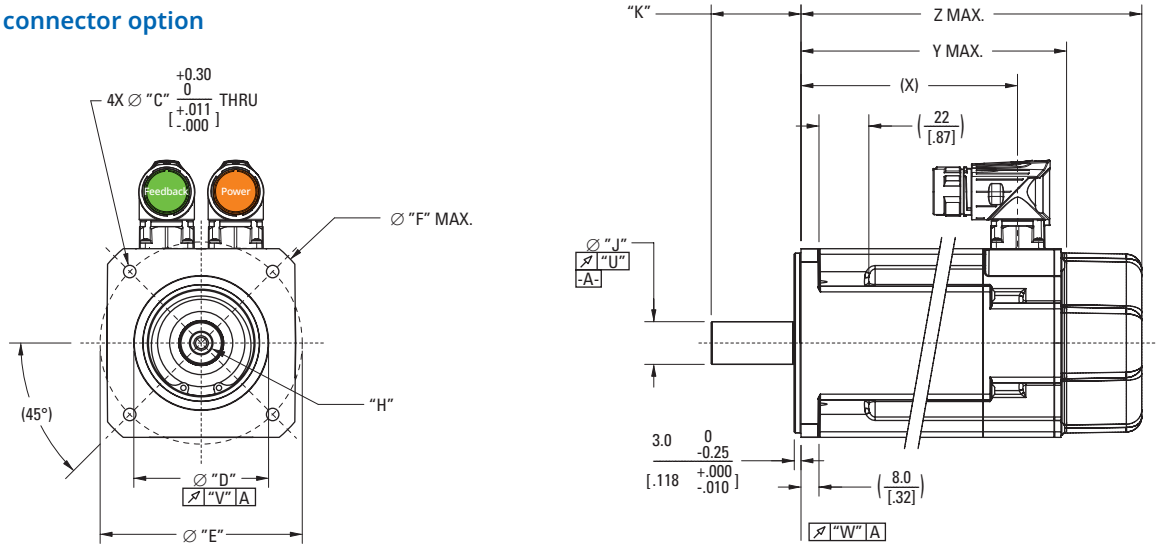

### G- connector option

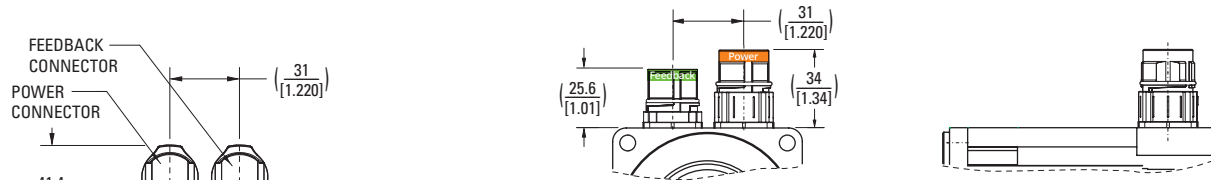

### 9- connector options

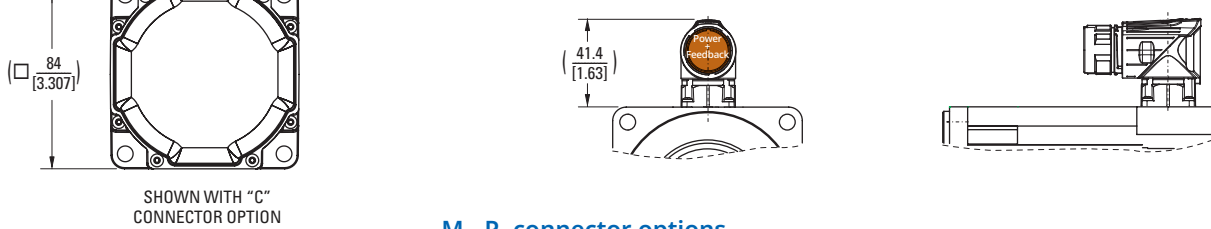

### M-, P- connector options

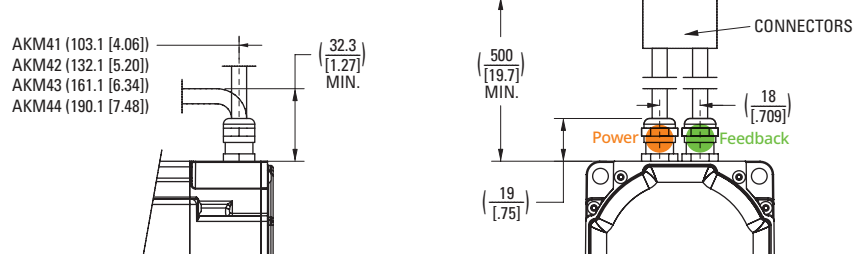

### Shaft-keyway dimensions

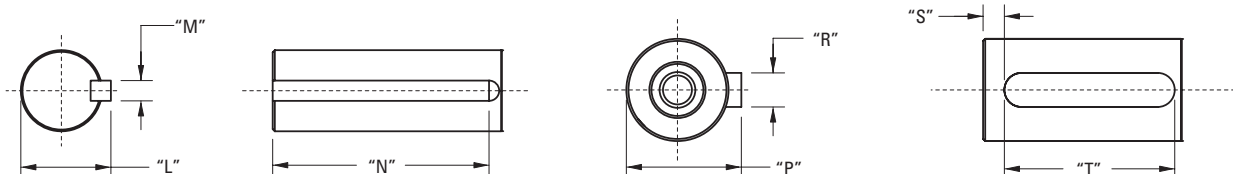

Dimensional data tables for callouts are located on the following page.

## AKM4x Frame Dimensional Data

### AKM4x Mounting Flange-Shaft Dimensional Data

Mounting Flange-Shaft	Hole Diameter "C"	Pilot Diameter "D"	Bolt Circle Dia. "E"	"F"	"H"	Shaft Diameter "J"	Shaft Length "K"	Shaft Dia. w/ Key "L"
AC	7 [0.276]	80 [3.1496]	100 [3.937]	-	D M5 DIN 332	19 [0.7480]	40.0 [1.57]	-
AN	7 [0.276]	80 [3.1496]	100 [3.937]	-	D M5 DIN 332	19 [0.7480]	40.0 [1.57]	-
BK	5.54 [0.218]	73.025 [2.8750]	98.43 [3.875]	-	-	15.875 [0.6250]	52.40 [2.063]	17.92 [0.706]
CC	5.54 [0.218]	60 [2.3622]	90 [3.543]	109 [4.291]	D M5 DIN 332	19 [0.7480]	40.0 [1.57]	-
CN	5.54 [0.218]	60 [2.3622]	90 [3.543]	109 [4.291]	D M5 DIN 332	19 [0.7480]	40.0 [1.57]	-
EK	5.54 [0.218]	73.025 [2.8750]	98.43 [3.875]	-	-	12.7 [0.5000]	31.75 [1.250]	14.09 [0.555]
GC	7 [0.276]	80 [3.1496]	100 [3.937]	-	D M5 DIN 332	14 [0.5512]	30 [1.18]	-
GN	7 [0.276]	80 [3.1496]	100 [3.937]	-	D M5 DIN 332	14 [0.5512]	30 [1.18]	-
HC	5.54 [0.218]	60 [2.3622]	90 [3.543]	109 [4.291]	D M5 DIN 332	14 [0.5512]	30 [1.18]	-
HN	5.54 [0.218]	60 [2.3622]	90 [3.543]	109 [4.291]	D M5 DIN 332	14 [0.5512]	30 [1.18]	-
KK	7 [0.276]	70 [2.7559]	90 [3.543]	109 [4.291]	-	16 [0.6299]	40.0 [1.57]	-

Mounting Flange-Shaft	Key Width "M"	Key Length "N"	Shaft Dia. w/ Key "P"	Key Width "R"	"S"	Key Length "T"	"U"	"V"	"W"
AC	-	-	21.5 [0.846]	6 [0.236]	4.00 [1.57]	32 [1.260]	0.040 [0.0015]	0.080 [0.0031]	0.080 [0.0031]
AN	-	-	-	-	-	-	0.040 [0.0015]	0.080 [0.0031]	0.080 [0.0031]
BK	4.762 [0.1875]	34.93 [1.375]	-	-	-	-	0.051 [0.0020]	0.10 [0.004]	0.10 [0.004]
CC	-	-	21.5 [0.846]	6 [0.236]	4.00 [1.57]	32 [1.260]	0.040 [0.0015]	0.080 [0.0031]	0.080 [0.0031]
CN	-	-	-	-	-	-	0.040 [0.0015]	0.080 [0.0031]	0.080 [0.0031]
EK	3.175 [0.1250]	19.05 [0.750]	-	-	-	-	0.051 [0.0020]	0.10 [0.004]	0.10 [0.004]
GC	-	-	16 [0.630]	5 [0.197]	6.00 [0.236]	20 [0.787]	0.040 [0.0015]	0.080 [0.0031]	0.080 [0.0031]
GN	-	-	-	-	-	-	0.040 [0.0015]	0.080 [0.0031]	0.080 [0.0031]
HC	-	-	16 [0.630]	5 [0.197]	6.00 [0.236]	20 [0.787]	0.040 [0.0015]	0.080 [0.0031]	0.080 [0.0031]
HN	-	-	-	-	-	-	0.040 [0.0015]	0.080 [0.0031]	0.080 [0.0031]
KK	5 [0.197]	30 [1.811]	-	-	-	-	0.051 [0.0020]	0.008 [0.0031]	0.008 [0.0031]

### AKM4x Motor Length Dimensional Data

No Brake (N)			
	X*	Y MAX	Z MAX
Connector	C-, 9-, G, M, P	C-, 9-, G, M, P	C-, 9-, G-
Feedback Option	R-, C-, 1-, 2-, Cx, Ex, Ax, Dx, Lx, Gx	R-, C-, 1-, 2-, Cx, Ex, Ax, Dx, Lx	Gx
AKM41	96.4 [3.8]	118.8 [4.68]	136.8 [5.39]
AKM42	125.4 [4.94]	147.8 [5.82]	165.8 [6.53]
AKM43	154.4 [6.08]	176.8 [6.96]	194.8 [7.67]
AKM44	183.4 [7.22]	205.8 [8.1]	223.8 [8.81]
Brake (2)			
	X*	Z MAX	
Connector	C-, 9-, G, M, P	C-, 9-, G, M, P	C-, 9-, G-
Feedback Option	R-, C-, 1-, 2-, Cx, Ex, Ax, Dx, Lx, Gx	R-, C-, 1-, 2-, Cx, Ex, Ax, Dx, Lx	Gx
AKM41	96.4 [3.8]	152.3 [6]	170.3 [6.7]
AKM42	125.4 [4.94]	181.3 [7.14]	199.3 [7.85]
AKM43	154.4 [6.08]	210.3 [8.28]	228.3 [8.99]
AKM43	183.4 [7.22]	239.3 [9.42]	257.3 [10.13]

\*For 0.5m shielded cable option (M or P), add 6.7 mm to "X"

Note 1: Dimensions are in mm [inches].

Note 2: Product designed in metric. English conversions provided for reference only.

#### Related Resources:

[Feedback Options and Specifications](#)

[Connector Options and Pinouts](#)

[Brake Option](#)

# AKM5x Series Motor Specifications

## AKM51-52 Performance Data – Up to 480 Vac (640 Vdc Bus) voltage

Parameters	Tol	Sym	Units	AKM51					AKM52					
				E	G	H	K	L	E	G	H	K	L	M
Max Rated Voltage ⑩	Max	-	Vac	480	480	480	240	240	480	480	480	480	480	240
			Vdc	640	640	640	320	320	640	640	640	640	640	320
Continuous Torque for ΔT winding = 100°C ①②⑦⑧⑨	Nom	T <sub>CS</sub>	Nm	4.70	4.75	4.79	4.9	4.89	8.34	8.43	8.48	8.6	8.67	8.60
			lb-in	41.6	42	42.4	43.4	43.3	73.8	74.6	75.1	76.1	76.7	76.1
Continuous Current for ΔT winding = 100°C ①②⑦⑧⑨	Nom	I <sub>CS</sub>	A <sub>RMS</sub>	2.75	4.84	6.0	9.4	11.9	2.99	4.72	5.9	9.3	11.6	13.1
Continuous Torque for ΔT winding = 60°C ②	Nom	T <sub>CS</sub>	Nm	3.76	3.8	3.83	3.92	3.91	6.67	6.74	6.78	6.88	6.94	6.88
			lb-in	33.3	33.6	33.9	34.7	34.6	59.0	59.7	60.0	61	61.4	61.0
Max Mechanical Speed ⑤	Nom	N <sub>max</sub>	rpm	6000	6000	6000	6000	6000	6000	6000	6000	6000	6000	6000
Peak Torque ①②	Nom	T <sub>p</sub>	Nm	11.6	11.7	11.7	11.9	12.0	21.3	21.4	21.6	21.9	22.0	21.9
			lb-in	103	104	104	105	106	189	189	191	194	195	194
Peak Current	Nom	I <sub>p</sub>	A <sub>RMS</sub>	8.2	14.5	18.0	28.2	35.7	9.00	14.1	17.7	27.9	34.8	39.4
75 Vdc	-	T <sub>Rtd</sub>	Nm	-	-	-	-	-	-	-	-	-	-	-
			lb-in	-	-	-	-	-	-	-	-	-	-	-
75 Vdc	-	N <sub>Rtd</sub>	rpm	-	-	-	-	-	-	-	-	-	-	-
75 Vdc	-	P <sub>Rtd</sub>	kW	-	-	-	-	-	-	-	-	-	-	-
			Hp	-	-	-	-	-	-	-	-	-	-	-
120 Vac (160 Vdc)	-	T <sub>Rtd</sub>	Nm	-	-	-	4.15	3.95	-	-	-	-	-	7.5
			lb-in	-	-	-	36.7	35.0	-	-	-	-	-	66
120 Vac (160 Vdc)	-	N <sub>Rtd</sub>	rpm	-	-	-	2500	3000	-	-	-	-	-	2000
120 Vac (160 Vdc)	-	P <sub>Rtd</sub>	kW	-	-	-	1.09	1.24	-	-	-	-	-	1.57
			Hp	-	-	-	1.46	1.66	-	-	-	-	-	2.11
240 Vac (320 Vdc)	-	T <sub>Rtd</sub>	Nm	4.41	4.02	3.87	2.35	2.00	-	7.69	7.53	6.8	6.40	5.20
			lb-in	39.0	35.6	34.3	20.8	17.7	-	68.1	66.6	60.2	56.6	46.0
240 Vac (320 Vdc)	-	N <sub>Rtd</sub>	rpm	1200	2500	3000	5500	6000	-	1500	1800	3000	3500	4500
240 Vac (320 Vdc)	-	P <sub>Rtd</sub>	kW	0.55	1.05	1.22	1.35	1.26	-	1.21	1.42	2.14	2.35	2.45
			Hp	0.74	1.41	1.63	1.81	1.69	-	1.62	1.90	2.86	3.15	3.28
400 Vac (560 Vdc)	-	T <sub>Rtd</sub>	Nm	3.98	2.62	1.95	-	-	7.61	7.06	6.26	3.9	3.27 <sup>⑩</sup>	-
			lb-in	35.2	23.2	17.3	-	-	67.3	62.5	55.4	34.5	2.89 <sup>⑩</sup>	-
400 Vac (560 Vdc)	-	N <sub>Rtd</sub>	rpm	2500	5000	6000	-	-	1500	2500	3500	5500	6000 <sup>⑩</sup>	-
400 Vac (560 Vdc)	-	P <sub>Rtd</sub>	kW	1.04	1.37	1.22	-	-	1.20	1.85	2.30	2.25	2.06 <sup>⑩</sup>	-
			Hp	1.40	1.84	1.64	-	-	1.60	2.48	3.08	3.01	2.76 <sup>⑩</sup>	-
480 Vac (640 Vdc)	-	T <sub>Rtd</sub>	Nm	3.80	1.94	1.95	-	-	7.3	6.66	5.77	3.25	-	-
			lb-in	33.6	17.2	17.3	-	-	65	58.9	51.1	28.7	-	-
480 Vac (640 Vdc)	-	N <sub>Rtd</sub>	rpm	3000	6000	6000	-	-	2000	3000	4000	6000	-	-
480 Vac (640 Vdc)	-	P <sub>Rtd</sub>	kW	1.19	1.22	1.23	-	-	1.53	2.09	2.42	2.04	-	-
			Hp	1.60	1.63	1.65	-	-	2.05	2.8	3.24	2.74	-	-

See following page for notes.

## AKM51-52 Motor Parameters

Parameters	Tol	Sym	Units	AKM51					AKM52					
				E	G	H	K	L	E	G	H	K	L	M
Torque Constant ①	±10%	K <sub>t</sub>	Nm/A <sub>rms</sub>	1.71	0.99	0.79	0.52	0.41	2.78	1.79	1.44	0.93	0.75	0.66
			lb-in/A <sub>rms</sub>	15.2	8.8	7.0	4.6	3.63	24.6	15.8	12.7	8.2	6.6	5.8
Back EMF Constant ⑥	±10%	K <sub>e</sub>	V <sub>rms</sub> /krpm	110	63.6	51.3	33.5	26.6	179	115	92.7	60.1	48.3	42.4
Motor Constant	Nom	K <sub>m</sub>	N-m/√W	0.469	0.477	0.465	0.49	0.447	0.761	0.760	0.767	0.775	0.784	0.770
			lb-in/√W	4.15	4.24	4.12	4.35	3.96	6.73	6.71	6.79	6.83	6.94	6.81
Resistance (line-line) ⑥	±10%	R <sub>m</sub>	ohm	9.0	2.87	1.85	0.75	0.49	9.0	3.7	2.35	0.96	0.61	0.49
Inductance (line-line)		L	mH	36.6	12.1	7.9	3.38	2.13	44.7	18.5	11.9	5	3.24	2.5
Inertia (includes Resolver feedback) ③	±10%	J <sub>m</sub>	kg-cm <sup>2</sup>	3.4					6.2					
			lb-in-s <sup>2</sup>	3.0E-03					5.5E-03					
Optional Brake Inertia (additional)	±10%	J <sub>m</sub>	kg-cm <sup>2</sup>	0.166					0.166					
			lb-in-s <sup>2</sup>	1.47E-04					1.47E-04					
Weight (w/o brake) ⑩		W	kg	4.2					5.8					
			lb	9.3					12.8					
Static Friction ①⑩		T <sub>f</sub>	Nm	0.022					0.04					
			lb-in	0.19					0.35					
Viscous Damping ①		K <sub>dv</sub>	Nm/krpm	0.033					0.042					
			lb-in/krpm	0.29					0.37					
Thermal Time Constant		TCT	minutes	20					24					
Thermal Resistance		R <sub>thw-a</sub>	°C/W	0.68					0.56					
Operating Ambient Temperature Range ⑩ ⑭ ⑮			°C	-20 to 40					-20 to 40					
Pole Pairs				5					5					
Heat Sink Size				12"x12"x1/2" Aluminum Plate					12"x12"x1/2" Aluminum Plate					

Additional windings may exist. Please contact Kollmorgen Customer Support for further information or to request custom winding options for your application requirements.

### Notes:

- ① Motor winding temperature rise, ΔT=100°C, at 40°C ambient.
- ② All data referenced to sinusoidal commutation.
- ③ Add parking brake if applicable for total inertia.
- ④ Motor with standard heat sink.
- ⑤ May be limited at some values of V<sub>bus</sub>.
- ⑥ Measured at 25°C.
- ⑦ Brake option reduces continuous torque ratings by:  
AKM51 = 0.15 Nm AKM52 = 0.26 Nm AKM53 = 0.35 Nm AKM54 = 0.43 Nm
- ⑧ Non-Resolver feedback options reduce continuous torque ratings by:  
AKM51 = 0.15 Nm AKM52 = 0.34 Nm AKM53 = 0.58 Nm AKM54 = 0.86 Nm
- ⑨ Motors with non-resolver feedback and brake option, reduce continuous torque by:  
AKM51 = 0.39 Nm AKM52 = 0.76 Nm AKM53 = 1.13 Nm AKM54 = 1.55 Nm
- ⑩ For motors with optional shaft seal, reduce torque shown by 0.13 Nm (1.2 lb-in), and increase T<sub>f</sub> by the same amount.
- ⑪ Brake option increases weight by 1.2 kg (2.64 lb).
- ⑫ Motors can be operated up to 480 Vac. For performances curves at voltages, listed or unlisted, please use our online Performance Curve Generator Tool.
- ⑬ Brake option will operate in this range in a non-condensing environment. See the Brake Option section for more information.
- ⑭ "AA" or "AB" BiSS feedback lower limit is -15°C; all other feedbacks meet or exceed this range.
- ⑮ Operation outside of this range may be possible. Please contact Kollmorgen Customer Support with your application requirements.
- ⑯ High speed continuous performance could be reduced by additional losses due to combination of source voltage, winding inductance, and servo drive PWM frequency. Please contact Kollmorgen Customer Support with your specific applications requirements.

### Related Resources:

- [AKM® Servo Motor Quick Guide](#) (for typical torque/speed performance)
- [Performance Curve Generator Tool](#) (generate AKM model specific performance curves)
- [Brake Option](#) (detailed brake specifications)

# AKM5x Series Motor Specifications

## AKM53-54 Performance Data – Up to 480 Vac (640 Vdc Bus) voltage

Parameters	Tol	Sym	Units	AKM53							AKM54					
				G	H	K	L	M	P	Q	G	H	K	L	N	P
Max Rated Voltage ①	Max	-	Vac	480	480	480	480	240	240	240	480	480	480	400	240	240
			Vdc	640	640	640	640	320	320	320	640	640	640	560	320	320
Continuous Torque for ΔT winding = 100°C ①②⑦⑧⑨	Nom	T <sub>Cs</sub>	Nm	11.4	11.5	11.6	11.6	11.4	11.4	11.6	14.3	14.2	14.4	14.1	14.1	14.4
			lb-in	101	102	102.7	103	101	101	103	127	126	127	125	125	127
Continuous Current for ΔT winding = 100°C ①②⑦⑧⑨	Nom	I <sub>Cs</sub>	A <sub>Rms</sub>	4.77	6.6	9.4	11.8	13.4	19.1	21.1	5	5.5	9.7	12.5	17.8	19.6
Continuous Torque for ΔT winding = 60°C ②	Nom	T <sub>Cs</sub>	Nm	9.10	9.21	9.28	9.28	9.10	9.10	9.26	11.41	11.5	11.5	11.3	11.3	11.49
			lb-in	80.5	81.5	82.1	82.1	80.5	80.5	82	101	102	102	100	100	101.7
Max Mechanical Speed ⑤	Nom	N <sub>max</sub>	rpm	6000	6000	6000	6000	6000	6000	6000	6000	6000	6000	6000	6000	
Peak Torque ①②	Nom	T <sub>p</sub>	Nm	29.9	30.0	30.3	30.3	29.7	29.8	30.2	38.0	37.5	38.4	37.5	37.6	38.0
			lb-in	265	266	268	268	263	264	267	336	332	340	332	333	337
Peak Current	Nom	I <sub>p</sub>	A <sub>Rms</sub>	14.4	19.8	28.2	35.4	40.2	57.4	63.3	15.0	16.5	29.1	37.5	53.4	58.8
75 Vdc Rated Torque (speed) ①②⑦⑧⑨⑩		T <sub>rtd</sub>	Nm	-	-	-	-	-	-	-	-	-	-	-	-	-
			lb-in	-	-	-	-	-	-	-	-	-	-	-	-	-
Rated Speed		N <sub>rtd</sub>	rpm	-	-	-	-	-	-	-	-	-	-	-	-	
Rated Power (speed) ①②⑦⑧⑨		P <sub>rtd</sub>	kW	-	-	-	-	-	-	-	-	-	-	-	-	-
			Hp	-	-	-	-	-	-	-	-	-	-	-	-	-
120 Vac (160 Vdc) Rated Torque (speed) ①②⑦⑧⑨⑩		T <sub>rtd</sub>	Nm	-	-	-	-	-	-	9.58	-	-	-	-	12.8	12.4
			lb-in	-	-	-	-	-	-	-	84.8	-	-	-	-	113
Rated Speed		N <sub>rtd</sub>	rpm	-	-	-	-	-	-	2500	-	-	-	-	1500	2000
Rated Power (speed) ①②⑦⑧⑨		P <sub>rtd</sub>	kW	-	-	-	-	-	-	2.51	-	-	-	-	2.01	2.6
			Hp	-	-	-	-	-	-	3.36	-	-	-	-	2.7	3.49
240 Vac (320 Vdc) Rated Torque (speed) ①②⑦⑧⑨⑩		T <sub>rtd</sub>	Nm	10.7	10.5	10.1	8.9	8.72	5.88	4.99⑥	-	13.4	12.7	11.5	9.85	9.23
			lb-in	94.5	93.0	89.4	79	77.2	52.0	44.2⑥	-	118	112	102	87.2	81.7
Rated Speed		N <sub>rtd</sub>	rpm	1000	1500	2000	3000	3000	5000	5500⑥	-	1000	1800	2500	3500	4000
Rated Power (speed) ①②⑦⑧⑨		P <sub>rtd</sub>	kW	1.12	1.65	2.12	2.8	2.74	3.08	2.87⑥	-	1.4	2.39	3.00	3.61	3.87
			Hp	1.50	2.21	2.84	3.75	3.67	4.13	3.85⑥	-	1.87	3.20	4.03	4.84	5.18
400 Vac (560 Vdc) Rated Torque (speed) ①②⑦⑧⑨⑩		T <sub>rtd</sub>	Nm	9.85	8.83	7.65	5.0⑥	-	-	-	12.92	12.6	10.05	8.13	-	-
			lb-in	87.2	78.2	67.7	44.3⑥	-	-	-	114.3	112	88.9	72.0	-	-
Rated Speed		N <sub>rtd</sub>	rpm	2000	3000	4000	5500⑥	-	-	-	1500	1800	3500	4500	-	-
Rated Power (speed) ①②⑦⑧⑨		P <sub>rtd</sub>	kW	2.06	2.77	3.2	2.88⑥	-	-	-	2.03	2.38	3.68	3.83	-	-
			Hp	2.77	3.72	4.3	3.86⑥	-	-	-	2.72	3.18	4.94	5.14	-	-
480 Vac (640 Vdc) Rated Torque (speed) ①②⑦⑧⑨⑩		T <sub>rtd</sub>	Nm	9.50	8.23	6.85	-	-	-	-	12.28	12.2	9.25	-	-	-
			lb-in	84.0	73	60.6	-	-	-	-	108.7	108	81.9	-	-	-
Rated Speed		N <sub>rtd</sub>	rpm	2400	3500	4500	-	-	-	-	2000	2000	4000	-	-	-
Rated Power (speed) ①②⑦⑧⑨		P <sub>rtd</sub>	kW	2.39	3.02	3.23	-	-	-	-	2.57	2.56	3.87	-	-	-
			Hp	3.20	4.05	4.33	-	-	-	-	3.45	3.43	5.19	-	-	-

See following page for notes.

## AKM53-54 Motor Parameters

Parameters	Tol	Sym	Units	AKM53								AKM54					
				G	H	K	L	M	P	Q	G	H	K	L	N	P	
Torque Constant ①	±10%	K <sub>t</sub>	Nm/A <sub>rms</sub>	2.39	1.74	1.24	0.99	0.85	0.60	0.55	2.87	2.58	1.51	1.13	0.79	0.73	
			lb-in/A <sub>rms</sub>	21.2	15.4	11	8.8	7.5	5.3	4.9	25.4	22.8	13.4	10.0	7.0	6.5	
Back EMF Constant ⑥	±10%	K <sub>e</sub>	V <sub>rms</sub> /krpm	154	112	79.8	63.6	54.7	38.4	35.5	185	166	96.6	72.9	51.3	47.3	
Motor Constant	Nom	K <sub>m</sub>	N-m/√W	0.979	0.986	0.983	0.973	0.972	0.926	0.980	1.164	1.19	1.18	1.14	1.14	1.163	
			lb-in/√W	8.67	8.73	8.72	8.61	8.57	8.19	8.76	10.31	10.5	10.4	10.1	10.1	10.21	
Resistance (line-line) ⑥	±10%	R <sub>m</sub>	ohm	3.97	2.1	1.06	0.69	0.51	0.28	0.21	4.08	3.2	1.08	0.65	0.33	0.27	
Inductance (line-line)		L	mH	21.3	11.4	5.7	3.64	2.7	1.3	1.14	22.9	18.3	6.2	3.5	1.75	1.49	
Inertia (includes Resolver feedback) ③	±10%	J <sub>m</sub>	kg-cm <sup>2</sup>	9.1								12					
			lb-in-s <sup>2</sup>	8.1E-03								0.011					
Optional Brake Inertia (additional)	±10%	J <sub>m</sub>	kg-cm <sup>2</sup>	0.166								0.166					
			lb-in-s <sup>2</sup>	1.47E-04								1.47E-04					
Weight (w/o brake) ⑩		W	kg	7.4								9					
			lb	16.3								19.8					
Static Friction ①⑩		T <sub>f</sub>	Nm	0.058								0.077					
			lb-in	0.51								0.68					
Viscous Damping ①		K <sub>dv</sub>	Nm/krpm	0.052								0.061					
			lb-in/krpm	0.46								0.54					
Thermal Time Constant		TCT	minutes	28								31					
Thermal Resistance		R <sub>thw-a</sub>	°C/W	0.50								0.45					
Operating Ambient Temperature Range ⑩ ⑭ ⑮			°C	-20 to 40								-20 to 40					
Pole Pairs				5								5					
Heat Sink Size				12"x12"x1/2" Aluminum Plate								12"x12"x1/2" Aluminum Plate					

Additional windings may exist. Please contact Kollmorgen Customer Support for further information or to request custom winding options for your application requirements.

**Notes:**

- ① Motor winding temperature rise, ΔT=100°C, at 40°C ambient.
- ② All data referenced to sinusoidal commutation.
- ③ Add parking brake if applicable for total inertia.
- ④ Motor with standard heat sink.
- ⑤ May be limited at some values of V<sub>bus</sub>.
- ⑥ Measured at 25°C.
- ⑦ Brake option reduces continuous torque ratings by:  
AKM51 = 0.15 Nm    AKM52 = 0.26 Nm    AKM53 = 0.35 Nm    AKM54 = 0.43 Nm
- ⑧ Non-Resolver feedback options reduce continuous torque ratings by:  
AKM51 = 0.15 Nm    AKM52 = 0.34 Nm    AKM53 = 0.58 Nm    AKM54 = 0.86 Nm
- ⑨ Motors with non-resolver feedback and brake option, reduce continuous torque by:  
AKM51 = 0.39 Nm    AKM52 = 0.76 Nm    AKM53 = 1.13 Nm    AKM54 = 1.55 Nm
- ⑩ For motors with optional shaft seal, reduce torque shown by 0.13 Nm (1.2 lb-in), and increase T<sub>f</sub> by the same amount.
- ⑪ Brake option increases weight by 1.2 kg (2.64 lb).
- ⑫ Motors can be operated up to 480 Vac. For performances curves at voltages, listed or unlisted, please use our online Performance Curve Generator Tool.
- ⑬ Brake option will operate in this range in a non-condensing environment. See the Brake Option section for more information.
- ⑭ "AA" or "AB" BiSS feedback lower limit is -15°C; all other feedbacks meet or exceed this range.
- ⑮ Operation outside of this range may be possible. Please contact Kollmorgen Customer Support with your application requirements.
- ⑯ High speed continuous performance could be reduced by additional losses due to combination of source voltage, winding inductance, and servo drive PWM frequency. Please contact Kollmorgen Customer Support with your specific applications requirements.

**Related Resources:**

- [AKM® Servo Motor Quick Guide](#) (for typical torque/speed performance)
- [Performance Curve Generator Tool](#) (generate AKM model specific performance curves)
- [Brake Option](#) (detailed brake specifications)

# AKM5x Series Motor Specifications

## AKM5x Frame Dimensional Drawings

AKM 2D/3D CAD models can be found at [Kollmorgen.com/DesignTools](http://Kollmorgen.com/DesignTools)

### C- connector option

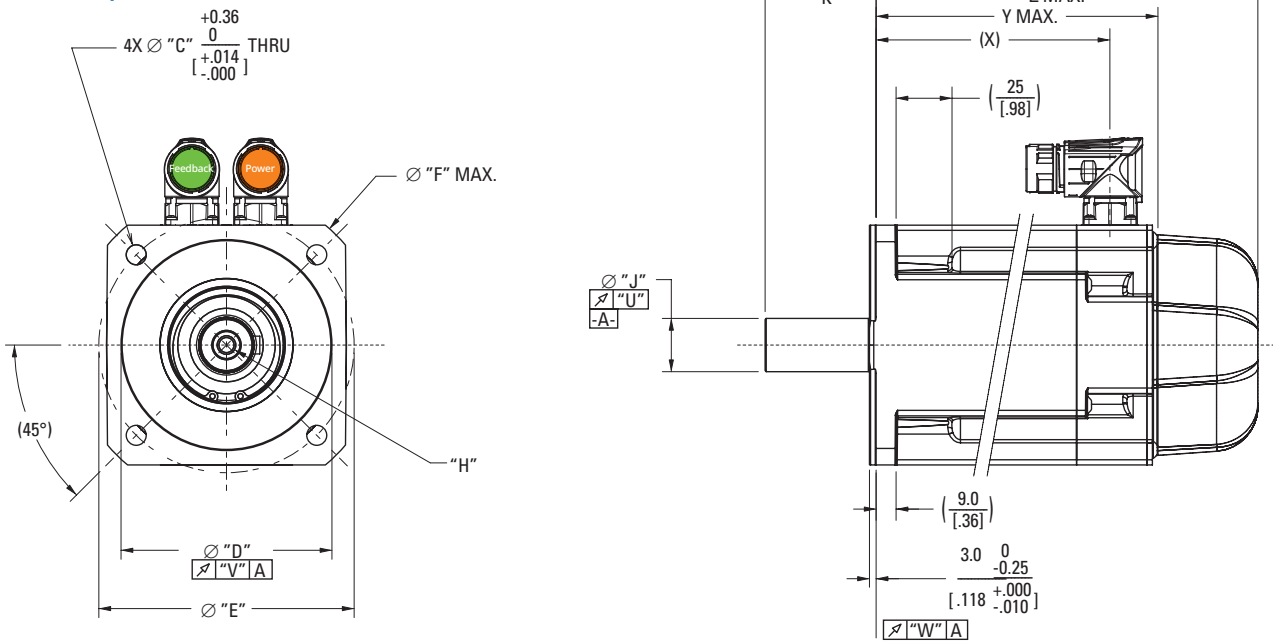

### G- connector option

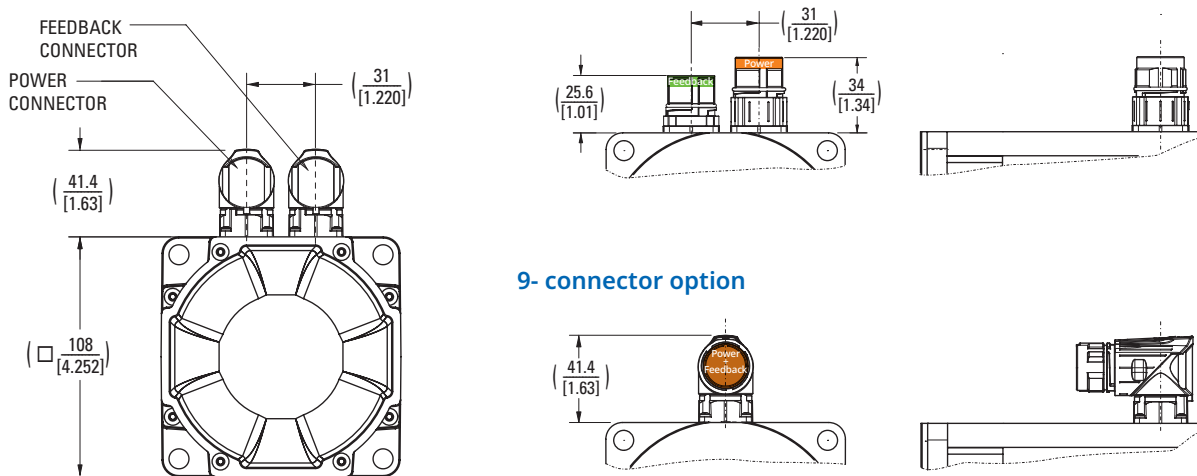

### 9- connector option

### Shaft-keyway dimensions

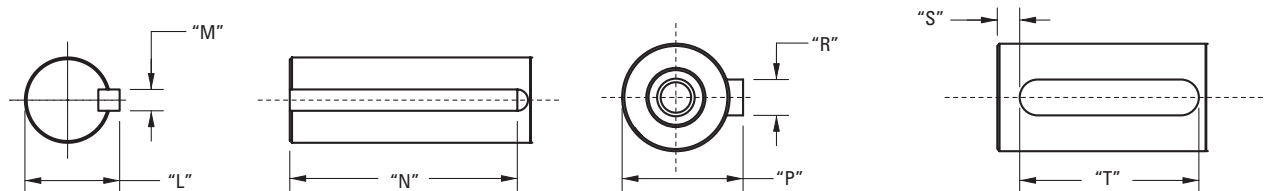

Dimensional data tables for callouts are located on the following page.

## AKM5x Frame Dimensional Data

### AKM5x Mounting Flange-Shaft Dimensional Data

Mounting Flange-Shaft	Hole Diameter "C"	Pilot Diameter "D"	Bolt Circle Dia. "E"	"F"	"H"	Shaft Diameter "J"	Shaft Length "K"	Shaft Dia. w/ Key "L"
AC	9 [0.354]	110 [4.3307]	130 [5.118]	-	D M8 DIN 332	24 [0.9449]	50.0 [1.97]	-
AN	9 [0.354]	110 [4.3307]	130 [5.118]	-	D M8 DIN 332	24 [0.9449]	50.0 [1.97]	-
BK	8.33 [0.328]	55.563 [2.1874]	125.73 [4.950]	-	-	19.05 [0.7500]	57.15 [2.250]	21.15 [0.83]
CC	9 [0.354]	95 [3.7402]	115 [4.528]	140 [5.512]	D M8 DIN 332	24 [0.9449]	50.0 [1.97]	-
CN	9 [0.354]	95 [3.7402]	115 [4.528]	140 [5.512]	D M8 DIN 332	24 [0.9449]	50.0 [1.97]	-
DK	8.33 [0.328]	63.5 [2.500]	127 [5.000]	-	-	19.05 [0.7500]	57.15 [2.250]	21.15 [0.83]
EK	8.33 [0.328]	55.563 [2.1874]	125.73 [4.950]	-	-	15.875 [0.6250]	44.45 [1.750]	17.91 [0.705]
GC	9 [0.354]	110 [4.3307]	130 [5.118]	-	D M6 DIN 332	19 [0.7480]	40 [1.57]	-
GN	9 [0.354]	110 [4.3307]	130 [5.118]	-	D M6 DIN 332	19 [0.7480]	40.0 [1.57]	-
HC	9 [0.354]	95 [3.7402]	115 [4.528]	140 [5.512]	D M6 DIN 332	19 [0.7480]	40 [1.57]	-
HN	9 [0.354]	95 [3.7402]	115 [4.528]	140 [5.512]	D M6 DIN 332	19 [0.7480]	40.0 [1.57]	-

Mounting Flange-Shaft	Key Width "M"	Key Length "N"	Shaft Dia. w/ Key "P"	Key Width "R"	"S"	Key Length "T"	"U"	"V"	"W"
AC	-	-	27 [1.063]	8 [0.3150]	5.00 [0.197]	40 [1.575]	0.040 [0.0015]	0.100 [0.0039]	0.100 [0.0039]
AN	-	-	-	-	-	-	0.040 [0.0015]	0.100 [0.0039]	0.100 [0.0039]
BK	4.763 [0.1875]	38.1 [1.500]	-	-	-	-	0.051 [0.0020]	0.10 [0.004]	0.10 [0.004]
CC	-	-	27 [1.063]	8 [0.3150]	5.00 [0.197]	40 [1.575]	0.040 [0.0015]	0.080 [0.0031]	0.080 [0.0031]
CN	-	-	-	-	-	-	0.040 [0.0015]	0.080 [0.0031]	0.080 [0.0031]
DK	4.763 [0.1875]	34.93 [1.375]	-	-	-	-	0.051 [0.0020]	0.05 [0.002]	0.10 [0.004]
EK	4.763 [0.1875]	38.1 [1.500]	-	-	-	-	0.051 [0.0020]	0.10 [0.004]	0.10 [0.004]
GC	-	-	21.5 [0.846]	6 [0.236]	4.00 [0.157]	32 [1.260]	0.040 [0.0015]	0.080 [0.0031]	0.080 [0.0031]
GN	-	-	-	-	-	-	-	-	-
HC	-	-	21.5 [0.846]	6 [0.236]	4.00 [0.157]	32 [1.260]	0.040 [0.0015]	0.080 [0.0031]	0.080 [0.0031]
HN	-	-	-	-	-	-	-	-	-

### AKM5x Motor Length Dimensional Data

Connector	No Brake (N)		
	X	Y MAX	Z MAX
	C-, 9-, G	C-, 9-, G	C-, 9-, G-
Feedback Option	R-, C-, 1-, 2-, Cx, Ex, Ax, Dx, Lx, Gx	R-, C-, 1-, 2-, Cx, Ex	Ax, Dx, Lx, Gx
AKM51	105.3 [4.15]	127.5 [5.02]	146 [5.75]
AKM52	136.3 [5.37]	158.5 [6.24]	177 [6.97]
AKM53	167.3 [6.59]	189.5 [7.46]	208 [8.19]
AKM54	198.3 [7.81]	220.5 [8.68]	239 [9.41]

Connector	Brake (2)		
	X	Z MAX	
	C-, 9-, G	C-, 9-, G	C-, 9-, G-
Feedback Option	R-, C-, 1-, 2-, Cx, Ex, Ax, Dx, Lx, Gx	R-, C-, 1-, 2-, Cx, Ex	Ax, Dx, Lx, Gx
AKM51	105.3 [4.15]	172.5 [6.79]	189 [7.44]
AKM52	136.3 [5.37]	203.5 [8.01]	220 [8.66]
AKM53	167.3 [6.59]	234.5 [9.23]	251 [9.88]
AKM54	198.3 [7.81]	265.5 [10.45]	282 [11.1]

Note 1: Dimensions are in mm [inches].

Note 2: Product designed in metric. English conversions provided for reference only.

#### Related Resources:

[Feedback Options and Specifications](#)

[Connector Options and Pinouts](#)

[Brake Option](#)

# AKM6x Series Motor Specifications

## AKM62-63 Performance Data – Up to 480 Vac (640 Vdc Bus) voltage

Parameters	Tol	Sym	Units	AKM62						AKM63							
				G	H	K	L	M	P	Q	G	H	K	L	M	N	Q
Max Rated Voltage ①	Max	-	Vac	480	480	480	480	480	240	240	480	480	480	480	480	480	240
			Vdc	640	640	640	640	640	320	320	640	640	640	640	640	640	320
Continuous Torque for ΔT winding = 100°C ①②⑦⑧⑨	Nom	T <sub>CS</sub>	Nm	11.9	11.9	12.2	12.2	12.2	12.3	12.0	16.5	16.6	16.8	16.8	17.0	17	16.7
			lb-in	105	105	108	108	108	109	106	146	147	149	149	150	150	148
Continuous Current for ΔT winding = 100°C ①②⑦⑧⑨	Nom	I <sub>CS</sub>	A <sub>RMS</sub>	4.9	5.4	9.6	12.0	13.4	18.8	21.8	4.5	5.6	9.9	11.1	13.8	17.4	22.4
Continuous Torque for ΔT winding = 60°C ②	Nom	T <sub>CS</sub>	Nm	9.5	9.5	9.8	9.8	9.72	9.8	9.6	13.2	13.3	13.4	13.4	13.6	13.6	13.4
			lb-in	84	84	87	87	86.0	87	85	117	118	119	119	120	120	119
Max Mechanical Speed ⑤	Nom	N <sub>max</sub>	rpm	6000	6000	6000	6000	6000	6000	6000	6000	6000	6000	6000	6000	6000	6000
Peak Torque ①②	Nom	T <sub>p</sub>	Nm	29.8	29.6	30.2	30.1	30.2	30.3	29.8	41.8	42.1	42.6	42.6	43.0	43.0	42.4
			lb-in	264	262	267	266	267	268	264	370	373	377	377	381	381	374
Peak Current	Nom	I <sub>p</sub>	A <sub>RMS</sub>	14.6	16.2	28.8	36.0	40.2	56	65	13.4	16.8	29.7	33.3	41.4	52.2	67.2
75 Vdc Rated Torque (speed) ①②⑦⑧⑨⑩		T <sub>rtd</sub>	Nm	-	-	-	-	-	-	-	-	-	-	-	-	-	-
			lb-in	-	-	-	-	-	-	-	-	-	-	-	-	-	-
75 Vdc Rated Speed		N <sub>rtd</sub>	rpm	-	-	-	-	-	-	-	-	-	-	-	-	-	-
75 Vdc Rated Power (speed) ①②⑦⑧⑨		P <sub>rtd</sub>	kW	-	-	-	-	-	-	-	-	-	-	-	-	-	-
			Hp	-	-	-	-	-	-	-	-	-	-	-	-	-	-
120 Vac (160 Vdc) Rated Torque (speed) ①②⑦⑧⑨⑩		T <sub>rtd</sub>	Nm	-	-	-	-	-	-	-	-	-	-	-	-	-	-
			lb-in	-	-	-	-	-	-	-	-	-	-	-	-	-	-
120 Vac (160 Vdc) Rated Speed		N <sub>rtd</sub>	rpm	-	-	-	-	-	-	-	-	-	-	-	-	-	-
120 Vac (160 Vdc) Rated Power (speed) ①②⑦⑧⑨		P <sub>rtd</sub>	kW	-	-	-	-	-	-	-	-	-	-	-	-	-	-
			Hp	-	-	-	-	-	-	-	-	-	-	-	-	-	-
240 Vac (320 Vdc) Rated Torque (speed) ①②⑦⑧⑨⑩		T <sub>rtd</sub>	Nm	-	11.2	10.4	10.0	9.50	8.1	6.5	-	-	14.9	14.4	14.3	13	11.9
			lb-in	-	99	92	89	84.1	72	58	-	-	132	127	127	115	105
240 Vac (320 Vdc) Rated Speed		N <sub>rtd</sub>	rpm	-	1000	2000	2500	3000	4500	5500	-	-	1500	1800	2000	3000	3500
240 Vac (320 Vdc) Rated Power (speed) ①②⑦⑧⑨		P <sub>rtd</sub>	kW	-	1.17	2.18	2.62	2.98	3.82	3.74	-	-	2.34	2.71	2.99	4.08	4.36
			Hp	-	1.57	2.92	3.51	4.00	5.12	5.02	-	-	3.14	3.63	4.01	5.47	5.85
400 Vac (560 Vdc) Rated Torque (speed) ①②⑦⑧⑨⑩		T <sub>rtd</sub>	Nm	10.4	10.2	9	7.42	5.70	-	-	14.9	14.6	12.9	12.9	11.3	9.6 <sup>Ⓣ</sup>	-
			lb-in	92	90.3	80	65.7	50.4	-	-	132	129	114	114	100	85 <sup>Ⓣ</sup>	-
400 Vac (560 Vdc) Rated Speed		N <sub>rtd</sub>	rpm	1800	2000	3500	5000	6000	-	-	1200	1500	3000	3000	4000	5000 <sup>Ⓣ</sup>	-
400 Vac (560 Vdc) Rated Power (speed) ①②⑦⑧⑨		P <sub>rtd</sub>	kW	1.96	2.14	3.3	3.89	3.58	-	-	1.87	2.29	4.05	4.05	4.73	5.03 <sup>Ⓣ</sup>	-
			Hp	2.63	2.86	4.42	5.21	4.80	-	-	2.51	3.08	5.43	5.43	6.34	6.74 <sup>Ⓣ</sup>	-
480 Vac (640 Vdc) Rated Torque (speed) ①②⑦⑧⑨⑩		T <sub>rtd</sub>	Nm	10.2	9.9	8	5.74	5.70	-	-	14.6	14.2	12	12.0	10.5	-	-
			lb-in	90	87.6	71	50.8	50.4	-	-	129	126	106	106	92.9	-	-
480 Vac (640 Vdc) Rated Speed		N <sub>rtd</sub>	rpm	2000	2400	4500	6000	6000	-	-	1500	1800	3500	3500	4500	-	-
480 Vac (640 Vdc) Rated Power (speed) ①②⑦⑧⑨		P <sub>rtd</sub>	kW	2.14	2.49	3.77	3.61	3.58	-	-	2.29	2.68	4.4	4.4	4.95	-	-
			Hp	2.86	3.34	5.05	4.84	4.80	-	-	3.07	3.59	5.9	5.90	6.63	-	-

## AKM62-63 Motor Parameters

Parameters	Tol	Sym	Units	AKM62							AKM63						
				G	H	K	L	M	P	Q	G	H	K	L	M	N	Q
Torque Constant ①	±10%	$K_t$	Nm/A <sub>rms</sub>	2.47	2.21	1.27	1.03	0.92	0.66	0.55	3.7	2.98	1.71	1.52	1.24	0.98	0.75
			lb-in/A <sub>rms</sub>	21.9	19.6	11.2	9.1	8.1	5.8	4.87	32.7	26.4	15.1	13.5	11.0	8.7	6.6
Back EMF Constant ⑥	±10%	$K_e$	V <sub>rms</sub> /krpm	159	142	82.1	65.5	58.8	42.2	35.5	238	192	110	98.2	79.9	63.3	48.3
Motor Constant	Nom	$K_m$	N-m/√W	0.992	0.989	1.006	0.949	0.984	0.984	1.00	1.288	1.32	1.308	1.26	1.30	1.281	1.28
			lb-in/√W	8.80	8.75	8.88	8.40	8.71	8.65	8.85	11.38	11.7	11.55	11.2	11.5	11.37	11.3
Resistance (line-line) ⑥	±10%	$R_m$	ohm	4.13	3.3	1.08	0.71	0.57	0.3	0.24	5.5	3.43	1.14	0.94	0.61	0.39	0.23
Inductance (line-line)		L	mH	31.7	25.4	8.5	5.4	4.4	2.2	1.6	43.5	28.1	9.3	7.4	4.9	3.1	1.8
Inertia (includes Resolver feedback) ③	±10%	$J_m$	kg-cm <sup>2</sup>	17							24						
			lb-in-s <sup>2</sup>	0.015							0.021						
Optional Brake Inertia (additional)	±10%	$J_m$	kg-cm <sup>2</sup>	0.668							0.668						
			lb-in-s <sup>2</sup>	5.91E-04							5.91E-04						
Weight (w/o brake) ⑩		W	kg	8.9							11.1						
			lb	19.6							24.4						
Static Friction ⑩⑩		$T_f$	Nm	0.05							0.1						
			lb-in	0.44							0.9						
Viscous Damping ①		$K_{dv}$	Nm/krpm	0.04							0.06						
			lb-in/krpm	0.35							0.53						
Thermal Time Constant		TCT	minutes	20							25						
Thermal Resistance		$R_{thw-a}$	°C/W	0.46							0.41						
Operating Ambient Temperature Range ⑩⑩⑤			°C	-20 to 40							-20 to 40						
Pole Pairs				5							5						
Heat Sink Size				18"x18"x1/2" Aluminum Plate							18"x18"x1/2" Aluminum Plate						

Additional windings may exist. Please contact Kollmorgen Customer Support for further information or to request custom winding options for your application requirements.

### Notes:

- ① Motor winding temperature rise,  $\Delta T=100^\circ\text{C}$ , at  $40^\circ\text{C}$  ambient.
- ② All data referenced to sinusoidal commutation.
- ③ Add parking brake if applicable for total inertia.
- ④ Motor with standard heat sink.
- ⑤ May be limited at some values of  $V_{bus}$ .
- ⑥ Measured at  $25^\circ\text{C}$ .
- ⑦ Brake option reduces continuous torque ratings by:  
AKM62 = 0.5 Nm AKM63 = 0.9 Nm AKM64 = 1.3 Nm AKM65 = 1.7 Nm
- ⑧ Non-Resolver feedback options reduce continuous torque ratings by:  
AKM62 = 0.9 Nm AKM63 = 1.2 Nm AKM64 = 1.5 Nm AKM65 = 1.8 Nm
- ⑨ Motors with non-resolver feedback and brake option, reduce continuous torque by:  
AKM62 = 1.6 Nm AKM63 = 2.4 Nm AKM64 = 3.1 Nm AKM65 = 4.0 Nm
- ⑩ For motors with optional shaft seal, reduce torque shown by 0.25 Nm (2.21 lb-in), and increase  $T_f$  by the same amount.
- ⑪ Brake option increases weight by 2.2 kg (4.84 lb).
- ⑫ Motors can be operated up to 480 Vac. For performances curves at voltages, listed or unlisted, please use our online Performance Curve Generator Tool.
- ⑬ Brake option will operate in this range in a non-condensing environment. See the Brake Option section for more information.
- ⑭ "AA" or "AB" BiSS feedback lower limit is  $-15^\circ\text{C}$ ; all other feedbacks meet or exceed this range.
- ⑮ Operation outside of this range may be possible. Please contact Kollmorgen Customer Support with your application requirements.
- ⑯ High speed continuous performance could be reduced by additional losses due to combination of source voltage, winding inductance, and servo drive PWM frequency. Please contact Kollmorgen Customer Support with your specific applications requirements.

### Related Resources:

- [AKM® Servo Motor Quick Guide](#) (for typical torque/speed performance)
- [Performance Curve Generator Tool](#) (generate AKM model specific performance curves)
- [Brake Option](#) (detailed brake specifications)

# AKM6x Series Motor Specifications

## AKM64-65 Performance Data – Up to 480 Vac (640 Vdc Bus) voltage

Parameters	Tol	Sym	Units	AKM64				AKM65				
				K	L	P	Q	K	L	M	N	P
Max Rated Voltage ⑧	Max	-	Vac	480	480	480	480	480	480	480	480	480
			Vdc	640	640	640	640	640	640	640	640	640
Continuous Torque for ΔT winding = 100°C ①②⑦⑧⑨	Nom	T <sub>CS</sub>	Nm	20.8	21.0	20.4	20.6	24.8	25.0	25.0	24.3	24.5
			Ib-in	184	186	181	182	219	221	221	215	217
Continuous Current for ΔT winding = 100°C ①②⑦⑧⑨	Nom	I <sub>CS</sub>	A <sub>RMS</sub>	9.2	12.8	18.6	20.7	9.8	12.2	13.6	17.8	19.8
Continuous Torque for ΔT winding = 60°C ②	Nom	T <sub>CS</sub>	Nm	16.6	16.8	16.3	16.5	19.8	20	20.0	19.4	19.6
			Ib-in	147	149	144	146	175	177	177	172	173
Max Mechanical Speed ⑤	Nom	N <sub>max</sub>	rpm	6000	6000	6000	6000	6000	6000	6000	6000	6000
Peak Torque ①②	Nom	T <sub>p</sub>	Nm	53	54	53	53	65	65	65	64	64
			Ib-in	469	478	469	469	575	575	575	566	566
Peak Current	Nom	I <sub>p</sub>	A <sub>RMS</sub>	27.5	38.4	56	62	29.4	36.6	40.9	53	59
75 Vdc Rated Torque (speed) ①②⑦⑧⑨⑩		T <sub>rtd</sub>	Nm	-	-	-	-	-	-	-	-	-
			Ib-in	-	-	-	-	-	-	-	-	-
Rated Speed		N <sub>rtd</sub>	rpm	-	-	-	-	-	-	-	-	-
Rated Power (speed) ①②⑦⑧⑨		P <sub>rtd</sub>	kW	-	-	-	-	-	-	-	-	-
			Hp	-	-	-	-	-	-	-	-	-
120 Vac (160 Vdc) Rated Torque (speed) ①②⑦⑧⑨⑩		T <sub>rtd</sub>	Nm	-	-	-	-	-	-	-	-	-
			Ib-in	-	-	-	-	-	-	-	-	-
Rated Speed		N <sub>rtd</sub>	rpm	-	-	-	-	-	-	-	-	-
Rated Power (speed) ①②⑦⑧⑨		P <sub>rtd</sub>	kW	-	-	-	-	-	-	-	-	-
			Hp	-	-	-	-	-	-	-	-	-
240 Vac (320 Vdc) Rated Torque (speed) ①②⑦⑧⑨⑩		T <sub>rtd</sub>	Nm	18.8	18.4	16	15.3	22.8	22.4	21.9	19.8	19.1
			Ib-in	166	163	142	135	202	198	194	175	169
Rated Speed		N <sub>rtd</sub>	rpm	1200	1500	2500	3000	1000	1300	1500	2000	2400
Rated Power (speed) ①②⑦⑧⑨		P <sub>rtd</sub>	kW	2.36	2.89	4.19	4.81	2.39	3.05	3.44	4.15	4.8
			Hp	3.17	3.87	5.62	6.45	3.2	4.09	4.61	5.56	6.44
400 Vac (560 Vdc) Rated Torque (speed) ①②⑦⑧⑨⑩		T <sub>rtd</sub>	Nm	17.2	15.6	11.9 <sup>Ⓣ</sup>	-	20.2	19.2	18.8	16	14.9 <sup>Ⓣ</sup>
			Ib-in	152	138	105 <sup>Ⓣ</sup>	-	179	170	166	142	132 <sup>Ⓣ</sup>
Rated Speed		N <sub>rtd</sub>	rpm	2000	3000	4500 <sup>Ⓣ</sup>	-	2000	2500	2700	3500	4000 <sup>Ⓣ</sup>
Rated Power (speed) ①②⑦⑧⑨		P <sub>rtd</sub>	kW	3.60	4.90	5.61 <sup>Ⓣ</sup>	-	4.23	5.03	5.32	5.86	6.24 <sup>Ⓣ</sup>
			Hp	4.83	6.57	7.52 <sup>Ⓣ</sup>	-	5.67	6.74	7.13	7.86	8.37 <sup>Ⓣ</sup>
480 Vac (640 Vdc) Rated Torque (speed) ①②⑦⑧⑨⑩		T <sub>rtd</sub>	Nm	16.3	14.4	-	-	19.7	18.3	18.1	14.7 <sup>Ⓣ</sup>	-
			Ib-in	144	127	-	-	174	162	160	130 <sup>Ⓣ</sup>	-
Rated Speed		N <sub>rtd</sub>	rpm	2500	3500	-	-	2200	2800	3000	4000 <sup>Ⓣ</sup>	-
Rated Power (speed) ①②⑦⑧⑨		P <sub>rtd</sub>	kW	4.27	5.28	-	-	4.54	5.37	5.69	6.16 <sup>Ⓣ</sup>	-
			Hp	5.72	7.07	-	-	6.08	7.2	7.62	8.25 <sup>Ⓣ</sup>	-

## AKM64-65 Motor Parameters

Parameters	Tol	Sym	Units	AKM64				AKM65				
				K	L	P	Q	K	L	M	N	P
Torque Constant ①	±10%	K <sub>t</sub>	Nm/A <sub>rms</sub>	2.28	1.66	1.1	0.99	2.55	2.07	1.85	1.38	1.26
			lb-in/A <sub>rms</sub>	20.2	14.7	9.7	8.8	22.6	18.3	16.4	12.2	11.2
Back EMF Constant ⑥	±10%	K <sub>e</sub>	V <sub>rms</sub> /krpm	147	107	71	0.64	164	133	119	88.8	80.5
Motor Constant	Nom	K <sub>m</sub>	N-m/√W	1.57	1.57	1.497	1.44	1.785	1.81	1.77	1.718	1.75
			lb-in/√W	13.9	13.9	13.20	12.8	15.81	16.0	15.6	15.19	15.4
Resistance (line-line) ⑥	±10%	R <sub>m</sub>	ohm	1.41	0.75	0.36	0.30	1.35	0.90	0.73	0.43	0.36
Inductance (line-line)		L	mH	11.8	6.2	2.8	1.9	11.4	7.6	6.1	3.4	2.8
Inertia (includes Resolver feedback) ③	±10%	J <sub>m</sub>	kg-cm <sup>2</sup>	32				40				
			lb-in-s <sup>2</sup>	0.028				0.035				
Optional Brake Inertia (additional)	±10%	J <sub>m</sub>	kg-cm <sup>2</sup>	0.668				0.668				
			lb-in-s <sup>2</sup>	5.91E-04				5.91E-04				
Weight (w/o brake) ⑩		W	kg	13.3				15.4				
			lb	29.3				33.9				
Static Friction ⑩⑪		T <sub>f</sub>	Nm	0.15				0.2				
			lb-in	1.3				1.8				
Viscous Damping ①		K <sub>dv</sub>	Nm/krpm	0.08				0.1				
			lb-in/krpm	0.71				0.9				
Thermal Time Constant		TCT	minutes	30				35				
Thermal Resistance		R <sub>thw-a</sub>	°C/W	0.38				0.35				
Operating Ambient Temperature Range ⑭⑮⑯			°C	-20 to 40				-20 to 40				
Pole Pairs				5				5				
Heat Sink Size				18"x18"x1/2" Aluminum Plate				18"x18"x1/2" Aluminum Plate				

Additional windings may exist. Please contact Kollmorgen Customer Support for further information or to request custom winding options for your application requirements.

Notes:

- ① Motor winding temperature rise, ΔT=100°C, at 40°C ambient.
- ② All data referenced to sinusoidal commutation.
- ③ Add parking brake if applicable for total inertia.
- ④ Motor with standard heat sink.
- ⑤ May be limited at some values of V<sub>bus</sub>.
- ⑥ Measured at 25°C.
- ⑦ Brake option reduces continuous torque ratings by:  
AKM62 = 0.5 Nm   AKM63 = 0.9 Nm   AKM64 = 1.3 Nm   AKM65 = 1.7 Nm
- ⑧ Non-Resolver feedback options reduce continuous torque ratings by:  
AKM62 = 0.9 Nm   AKM63 = 1.2 Nm   AKM64 = 1.5 Nm   AKM65 = 1.8 Nm
- ⑨ Motors with non-resolver feedback and brake option, reduce continuous torque by:  
AKM62 = 1.6 Nm   AKM63 = 2.4 Nm   AKM64 = 3.1 Nm   AKM65 = 4.0 Nm
- ⑩ For motors with optional shaft seal, reduce torque shown by 0.25 Nm (2.21 lb-in), and increase T<sub>f</sub> by the same amount.
- ⑪ Brake option increases weight by 2.2 kg (4.84 lb).
- ⑫ Motors can be operated up to 480 Vac. For performances curves at voltages, listed or unlisted, please use our online Performance Curve Generator Tool.
- ⑬ Brake option will operate in this range in a non-condensing environment. See the Brake Option section for more information.
- ⑭ "AA" or "AB" BiSS feedback lower limit is -15°C; all other feedbacks meet or exceed this range.
- ⑮ Operation outside of this range may be possible. Please contact Kollmorgen Customer Support with your application requirements.
- ⑯ High speed continuous performance could be reduced by additional losses due to combination of source voltage, winding inductance, and servo drive PWM frequency. Please contact Kollmorgen Customer Support with your specific applications requirements.

### Related Resources:

- [AKM® Servo Motor Quick Guide](#) (for typical torque/speed performance)
- [Performance Curve Generator Tool](#) (generate AKM model specific performance curves)
- [Brake Option](#) (detailed brake specifications)

# AKM6x Series Motor Specifications

## AKM6x Frame Dimensional Drawings

AKM 2D/3D CAD models can be found at [Kollmorgen.com/DesignTools](http://Kollmorgen.com/DesignTools)

### C- connector option

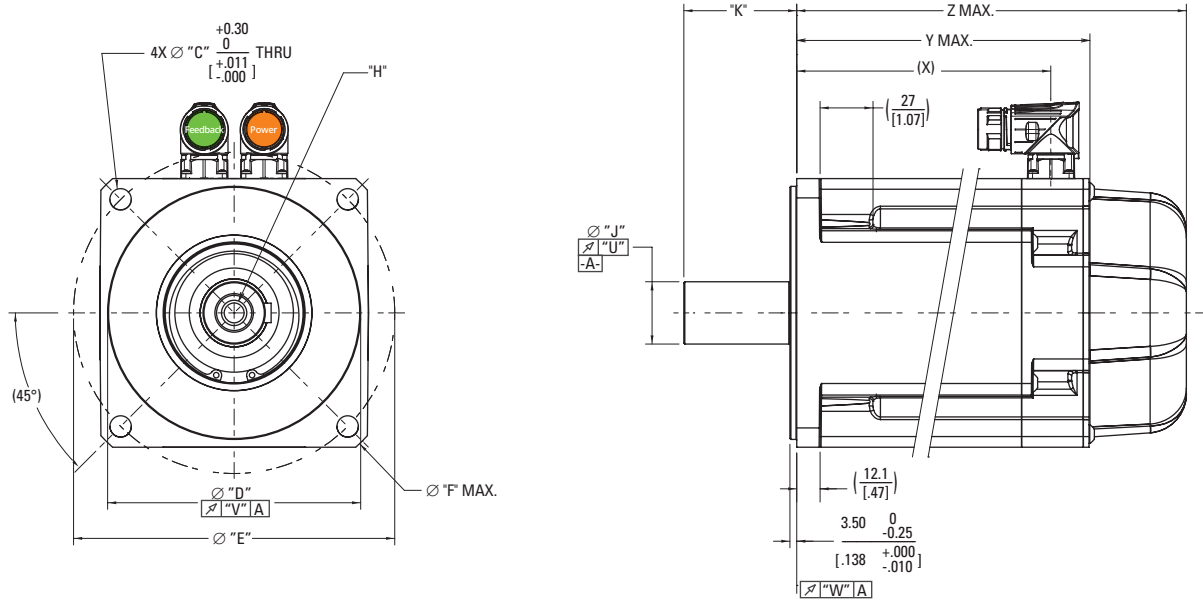

### G- connector option

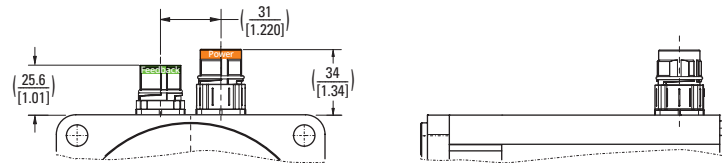
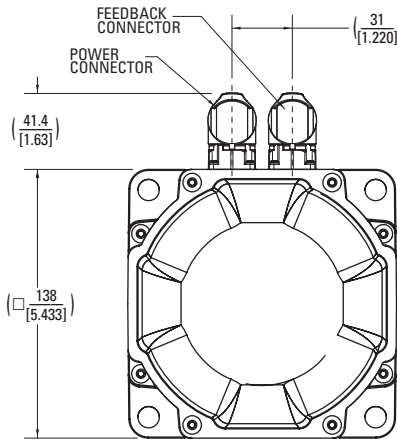

### 9- connector option

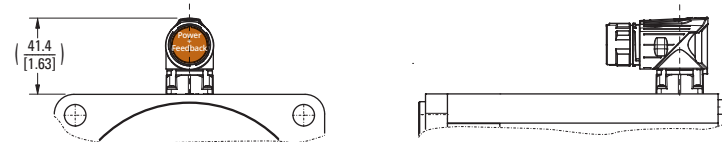

### Shaft-keyway dimensions

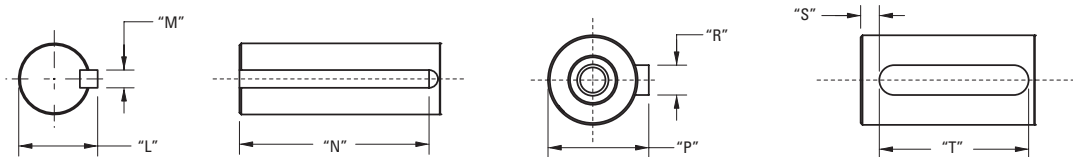

Dimensional data tables for callouts are located on the following page.

## AKM6x Frame Dimensional Data

### AKM6x Mounting Flange-Shaft Dimensional Data

Mounting Flange-Shaft	Hole Diameter "C"	Pilot Diameter "D"	Bolt Circle Dia. "E"	"F"	"H"	Shaft Diameter "J"	Shaft Length "K"	Shaft Dia. w/ Key "L"
AC	11.00 [0.433]	130 [5.1181]	165.00 [6.496]	-	D M12 DIN 332	32 [1.2598]	58 [2.28]	-
AN	11.00 [0.433]	130 [5.1181]	165.00 [6.496]	-	D M12 DIN 332	32 [1.2598]	58 [2.28]	-
GC	11.00 [0.433]	130 [5.1181]	165.00 [6.496]	-	D M8 DIN 332	24 [0.9449]	50 [1.97]	-
GN	11.00 [0.433]	130 [5.1181]	165.00 [6.496]	-	D M8 DIN 332	24 [0.9449]	50 [1.97]	-
KK	9.00 [0.354]	110 [4.3307]	145.00 [5.709]	165 [6.496]	-	28 [1.1024]	60 [2.36]	31 [1.220]
LK	3/18 - 16 UNC-2B	114.3 [4.5000]	149.225 [5.875]	165 [6.496]	-	28.580 [1.1250]	69.85 [2.75]	31.39 [1.236]

Mounting Flange-Shaft	Key Width "M"	Key Length "N"	Shaft Dia. w/ Key "P"	Key Width "R"	"S"	Key Length "T"	"U"	"V"	"W"
AC	-	-	35 [1.378]	10 [0.3937]	5.00 [0.197]	45 [1.772]	0.050 [0.0019]	0.100 [0.0039]	0.100 [0.0039]
AN	-	-	-	-	-	-	0.050 [0.0019]	0.100 [0.0039]	0.100 [0.0039]
GC	-	-	27 [1.063]	8 [0.3150]	5.00 [0.197]	40 [1.575]	0.050 [0.0019]	0.100 [0.0039]	0.100 [0.0039]
GN	-	-	-	-	-	-	0.050 [0.0019]	0.100 [0.0039]	0.100 [0.0039]
KK	8 [0.3150]	50 [1.969]	-	-	-	-	0.050 [0.0019]	0.100 [0.0039]	0.100 [0.0039]
LK	6.35 [2.75]	38.1 [1.500]	-	-	-	-	0.050 [0.0019]	0.100 [0.0039]	0.100 [0.0039]

### AKM6x Motor Length Dimensional Data

	No Brake (N)		
	X	Y MAX	Z MAX
Connector	C-, 9-, G	C-, 9-, G	C-, 9-, G-
Feedback Option	R-, C-, 1-, 2-, Cx, Ex, Ax, Dx, Lx, Gx	R-, C-, 1-, 2-, Cx, Ex	Ax, Dx, Lx, Gx
AKM62	130.5 [5.14]	153.7 [6.05]	172.2 [6.78]
AKM63	155.5 [6.12]	178.7 [7.04]	197.2 [7.76]
AKM64	180.5 [7.11]	203.7 [8.02]	222.2 [8.75]
AKM65	205.5 [8.09]	228.7 [9]	247.2 [9.73]

	Brake (2)		
	X	Z MAX	
Connector	C-, 9-, G	C-, 9-, G	C-, 9-, G-
Feedback Option	R-, C-, 1-, 2-, Cx, Ex, Ax, Dx, Lx, Gx	R-, C-, 1-, 2-, Cx, Ex	Ax, Dx, Lx, Gx
AKM62	130.5 [5.14]	200.7 [7.9]	219.7 [8.65]
AKM63	155.5 [6.12]	225.7 [8.89]	244.7 [9.63]
AKM64	180.5 [7.11]	250.7 [9.87]	269.7 [10.62]
AKM65	205.5 [8.09]	275.7 [10.85]	294.7 [11.6]

Note 1: Dimensions are in mm [inches].

Note 2: Product designed in metric. English conversions provided for reference only.

#### Related Resources:

[Feedback Options and Specifications](#)

[Connector Options and Pinouts](#)

[Brake Option](#)

# AKM7x Series Motor Specifications

## AKM7x Performance Data – Up to 480 Vac (640 Vdc Bus) voltage

Parameters	Tol	Symbol	Units	AKM72					AKM73				AKM74			
				K	L	M	P	Q	L	M	P	Q	L	P	Q	
Max Rated Voltage ⑩	Max	-	Vac	480	480	480	480	480	480	480	480	480	480	480	480	480
			Vdc	640	640	640	640	640	640	640	640	640	640	640	640	640
Continuous Torque for ΔT winding = 100°C ①②⑦⑧⑨	Nom	T <sub>Cs</sub>	Nm	29.7	30	30	29.4	29.5	42	42	41.6	41.5	53.0	52.5	52.2	
			Ib-in	263	266	266	260	261	372	372	368	367	469	465	426	
Continuous Current for ΔT winding = 100°C ①②⑦⑧⑨	Nom	I <sub>Cs</sub>	A <sub>RMS</sub>	9.3	11.5	13.0	18.7	23.5	12.1	13.6	19.5	24.5	12.8	18.4	26.1	
Continuous Torque for ΔT winding = 60°C ②	Nom	T <sub>Cs</sub>	Nm	23.8	24	24	23.5	23.6	33.6	33.6	33.3	33.2	42.4	42.0	41.8	
			Ib-in	211	212	212	208	209	297	297	295	294	375	372	370	
Max Mechanical Speed ⑤	Nom	N <sub>max</sub>	rpm	6000	6000	6000	6000	6000	6000	6000	6000	6000	6000	6000	6000	
Peak Torque ①②	Nom	T <sub>p</sub>	Nm	79	80	80	78	78	113	113	111	111	143	142	141	
			Ib-in	699	708	708	690	690	1000	1000	985	982	1269	1253	1250	
Peak Current	Nom	I <sub>p</sub>	A <sub>RMS</sub>	27.9	34.5	39.0	56.1	70.5	36.3	40.8	58.6	73.5	38.5	55.2	78.3	
75 Vdc Rated Torque (speed) ①②⑦⑧⑨⑩		T <sub>Rtd</sub>	Nm	-	-	-	-	-	-	-	-	-	-	-	-	
			Ib-in	-	-	-	-	-	-	-	-	-	-	-	-	
Rated Speed		N <sub>Rtd</sub>	rpm	-	-	-	-	-	-	-	-	-	-	-	-	
Rated Power (speed) ①②⑦⑧⑨		P <sub>Rtd</sub>	kW	-	-	-	-	-	-	-	-	-	-	-	-	
			Hp	-	-	-	-	-	-	-	-	-	-	-	-	
120 Vac (160 Vdc) Rated Torque (speed) ①②⑦⑧⑨⑩		T <sub>Rtd</sub>	Nm	-	-	-	-	-	-	-	-	-	-	-	-	
			Ib-in	-	-	-	-	-	-	-	-	-	-	-	-	
Rated Speed		N <sub>Rtd</sub>	rpm	-	-	-	-	-	-	-	-	-	-	-	-	
Rated Power (speed) ①②⑦⑧⑨		P <sub>Rtd</sub>	kW	-	-	-	-	-	-	-	-	-	-	-	-	
			Hp	-	-	-	-	-	-	-	-	-	-	-	-	
240 Vac (320 Vdc) Rated Torque (speed) ①②⑦⑧⑨⑩		T <sub>Rtd</sub>	Nm	-	-	-	23.8	23.3	-	-	34.7	33.4	-	-	41.9	
			Ib-in	-	-	-	211	205	-	-	307	296	-	-	371	
Rated Speed		N <sub>Rtd</sub>	rpm	-	-	-	1800	2000	-	-	1300	1500	-	-	1300	
Rated Power (speed) ①②⑦⑧⑨		P <sub>Rtd</sub>	kW	-	-	-	4.49	4.86	-	-	4.72	5.25	-	-	5.7	
			Hp	-	-	-	6.01	6.52	-	-	6.33	7.04	-	-	7.64	
400 Vac (560 Vdc) Rated Torque (speed) ①②⑦⑧⑨⑩		T <sub>Rtd</sub>	Nm	25.1	24.3	23.6	20.1	16.3	34.4	33.8	28.5	25.2	43.5	39.6	31.5	
			Ib-in	222	215	209	178	144	304	299	252	223	385	350	279	
Rated Speed		N <sub>Rtd</sub>	rpm	1500	1800	2000	3000	4000	1400	1500	2400	3000	1200	1800	2500	
Rated Power (speed) ①②⑦⑧⑨		P <sub>Rtd</sub>	kW	3.94	4.58	4.94	6.31	6.83	5.04	5.31	7.16	7.92	5.47	7.46	8.25	
			Hp	5.28	6.14	6.62	8.46	9.16	6.76	7.12	9.60	10.6	7.33	10.0	11.1	
480 Vac (640 Vdc) Rated Torque (speed) ①②⑦⑧⑨⑩		T <sub>Rtd</sub>	Nm	24.0	23.6	22.1	18.2	14.1 <sup>Ⓜ</sup>	33.8	32.1	26.3	22.0	41.5	35.9	27.3	
			Ib-in	212	209	196	161	125 <sup>Ⓜ</sup>	299	284	233	195	367	318	242	
Rated Speed		N <sub>Rtd</sub>	rpm	1800	2000	2500	3500	4500 <sup>Ⓜ</sup>	1500	1800	2800	3500	1400	2000	3000	
Rated Power (speed) ①②⑦⑧⑨		P <sub>Rtd</sub>	kW	4.52	4.94	5.79	6.67	6.65 <sup>Ⓜ</sup>	5.31	6.05	7.71	8.07	6.08	7.52	8.58	
			Hp	6.06	6.62	7.76	8.94	8.91 <sup>Ⓜ</sup>	7.12	8.11	10.3	10.8	8.16	10.1	11.5	

See following page for notes.

## AKM7x Motor Parameters

Parameters	Tol	Symbol	Units	AKM72					AKM73				AKM74		
				K	L	M	P	Q	L	M	P	Q	L	P	Q
Torque Constant ①	±10%	K <sub>t</sub>	Nm/A <sub>rms</sub>	3.23	2.62	2.33	1.58	1.26	3.49	3.11	2.13	1.69	4.14	2.84	2.0
			lb-in/A <sub>rms</sub>	28.6	23.2	20.6	14.0	11.2	31.0	27.4	18.9	15	36.6	25.1	17.7
Back EMF Constant ⑥	±10%	K <sub>e</sub>	V <sub>rms</sub> /krpm	208	169	150	102	81	225	200	137	109	266	183	129
Motor Constant	Nom	K <sub>m</sub>	N-m/√W	2.261	2.21	2.290	2.18	2.08	2.93	2.903	2.82	2.67	3.51	3.38	3.27
			lb-in/√W	20.02	19.6	20.25	19.3	18.4	25.9	25.66	25.0	23.6	31.0	29.9	28.9
Resistance (line-line) ⑥	±10%	R <sub>m</sub>	ohm	1.36	0.92	0.69	0.35	0.23	0.95	0.76	0.38	0.25	0.93	0.47	0.24
Inductance (line-line)		L	mH	20.7	13.6	10.8	5.0	3.2	15.7	12.4	5.9	3.7	16.4	7.7	3.8
Inertia (includes Resolver feedback) ③	±10%	J <sub>m</sub>	kg-cm <sup>2</sup>	65					92				120		
			lb-in-s <sup>2</sup>	0.057					0.082				0.11		
Optional Brake Inertia (additional)	±10%	J <sub>m</sub>	kg-cm <sup>2</sup>	1.589					1.589				1.589		
			lb-in-s <sup>2</sup>	1.41E-03					1.41E-03				1.41E-03		
Weight (w/o brake) ⑩		W	kg	19.7					26.7				33.6		
			lb	43.4					58.8				74.0		
Static Friction ①⑩		T <sub>f</sub>	Nm	0.16					0.24				0.33		
			lb-in	1.4					2.1				2.9		
Viscous Damping ①		K <sub>dv</sub>	Nm/krpm	0.06					0.13				0.2		
			lb-in/krpm	0.5					1.2				1.8		
Thermal Time Constant		TCT	minutes	46					53				60		
Thermal Resistance		R <sub>thw-a</sub>	°C/W	0.39					0.33				0.30		
Operating Ambient Temperature Range ⑭⑮⑯			°C	-20 to 40					-20 to 40				-20 to 40		
Pole Pairs				5					5				5		
Heat Sink Size				18"x18"x1/2" Aluminum Plate					18"x18"x1/2" Aluminum Plate				18"x18"x1/2" Aluminum Plate		

Additional windings may exist. Please contact Kollmorgen Customer Support for further information or to request custom winding options for your application requirements.

### Notes:

- ① Motor winding temperature rise, ΔT=100°C, at 40°C ambient.
- ② All data referenced to sinusoidal commutation.
- ③ Add parking brake if applicable for total inertia.
- ④ Motor with standard heat sink.
- ⑤ May be limited at some values of V<sub>bus</sub>.
- ⑥ Measured at 25°C.
- ⑦ Brake option reduces continuous torque ratings by 1 Nm.
- ⑧ Non-Resolver feedback options reduce continuous torque ratings by:  
AKM72 = 2.0 Nm    AKM73 = 2.7 Nm    AKM74 = 3.4 Nm
- ⑨ Motors with non-resolver feedback and brake option, reduce continuous torque by:  
AKM72 = 3.9 Nm    AKM73 = 5.1 Nm    AKM74 = 6.2 Nm
- ⑩ For motors with optional shaft seal, reduce torque shown by 0.25 Nm (2.21 lb-in), and increase T<sub>f</sub> by the same amount.
- ⑪ Brake option increases weight by 3.1 kg (6.82 lb).
- ⑫ Motors can be operated up to 480 Vac. For performances curves at voltages, listed or unlisted, please use our online Performance Curve Generator Tool.
- ⑬ Brake option will operate in this range in a non-condensing environment. See the Brake Option section for more information.
- ⑭ "AA" or "AB" BiSS feedback lower limit is -15°C; all other feedbacks meet or exceed this range.
- ⑮ Operation outside of this range may be possible. Please contact Kollmorgen Customer Support with your application requirements.
- ⑯ High speed continuous performance could be reduced by additional losses due to combination of source voltage, winding inductance, and servo drive PWM frequency. Please contact Kollmorgen Customer Support with your specific applications requirements.

### Related Resources:

- [AKM® Servo Motor Quick Guide](#) (for typical torque/speed performance)
- [Performance Curve Generator Tool](#) (generate AKM model specific performance curves)
- [Brake Option](#) (detailed brake specifications)

# AKM7x Series Motor Specifications

## AKM7x Frame Dimensional Drawings

AKM 2D/3D CAD models can be found at [Kollmorgen.com/DesignTools](http://Kollmorgen.com/DesignTools)

### C- connector option

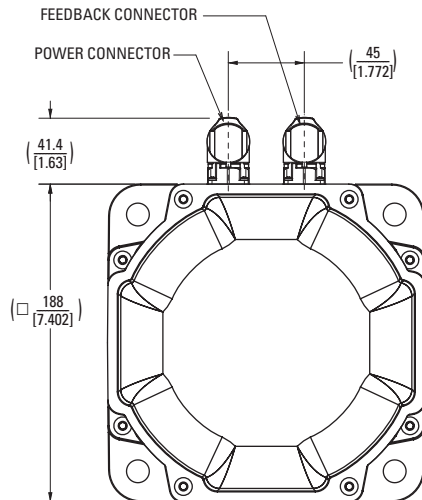
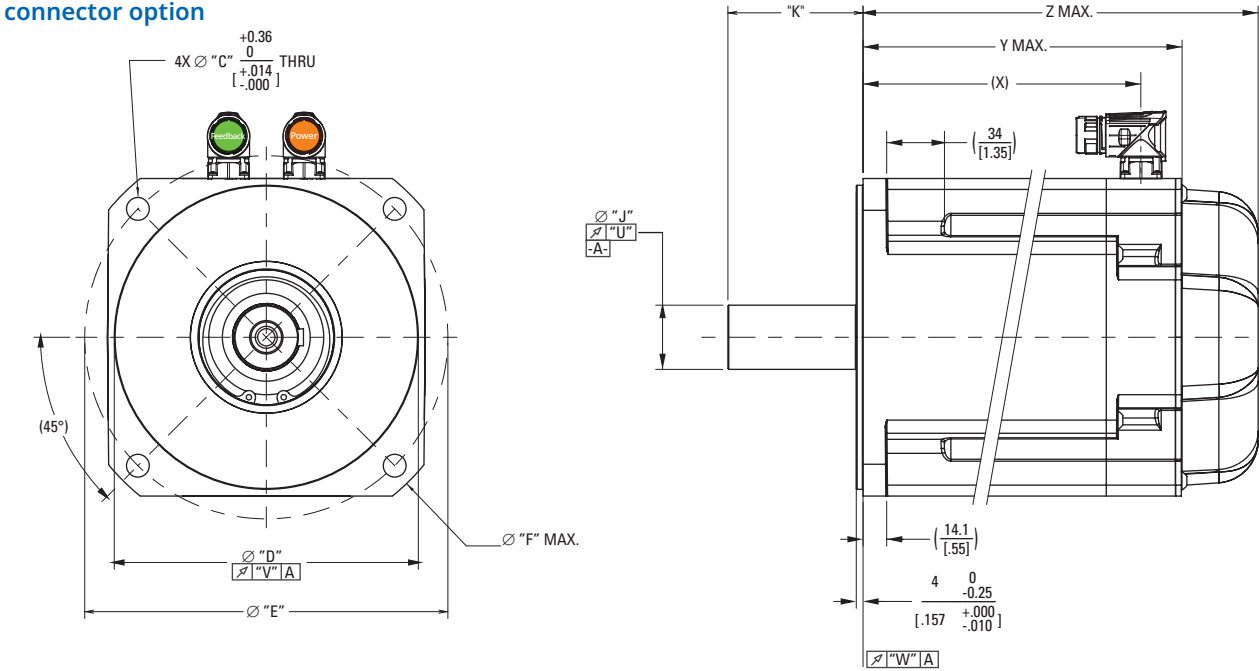

### G- connector option

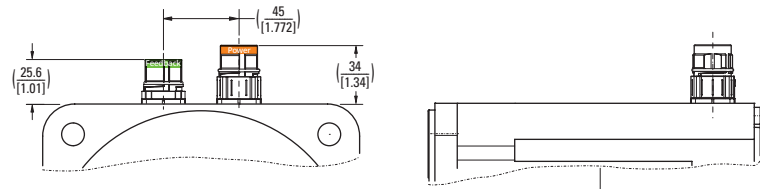

### H- connector option

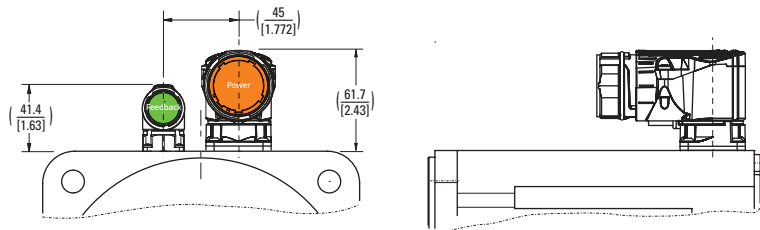

### Shaft-keyway dimensions

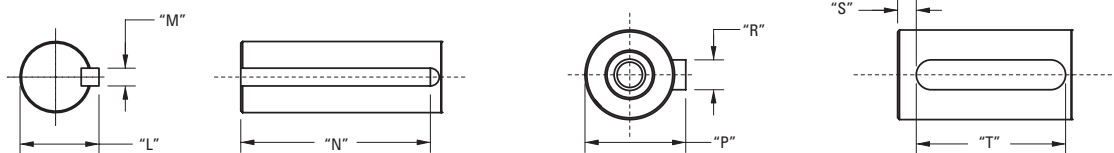

Dimensional data tables for callouts are located on the following page.

## AKM7x Frame Dimensional Data

### AKM7x Mounting Flange-Shaft Dimensional Data

Mounting Flange-Shaft	Hole Diameter "C"	Pilot Diameter "D"	Bolt Circle Dia. "E"	"F"	"H"	Shaft Diameter "J"	Shaft Length "K"	Shaft Dia. w/ Key "L"
AC	13.50 [0.531]	180 [7.0866]	215.00 [8.465]	-	D M12 DIN 332	38 [1.496]	80 [3.15]	-
AN	13.50 [0.531]	180 [7.0866]	215.00 [8.465]	-	D M12 DIN 332	38 [1.496]	80 [3.15]	-
GC	13.50 [0.531]	180 [7.0866]	215.00 [8.465]	-	D M12 DIN 332	32 [1.5298]	58.5 [2.30]	-
GN	13.50 [0.531]	180 [7.0866]	215.00 [8.465]	-	D M12 DIN 332	32 [1.5298]	58.5 [2.30]	-
KK	13.50 [0.531]	114.3 [4.5000]	200 [7.874]	225 [8.858]	-	35 [1.3779]	79 [3.11]	38 [1.496]

Mounting Flange-Shaft	Key Width "M"	Key Length "N"	Shaft Dia. w/ Key "P"	Key Width "R"	"S"	Key Length "T"	"U"	"V"	"W"
AC	-	-	41 [1.614]	10 [0.3937]	5.00 [0.197]	70 [2.756]	0.050 [0.0019]	0.100 [0.0039]	0.100 [0.0039]
AN	-	-	-	-	-	-	0.050 [0.0019]	0.100 [0.0039]	0.100 [0.0039]
GC	-	-	35 [1.378]	108 [0.3937]	4 [0.157]	50 [1.969]	0.050 [0.0019]	0.100 [0.0039]	0.100 [0.0039]
GN	-	-	-	-	-	-	0.050 [0.0019]	0.100 [0.0039]	0.100 [0.0039]
KK	10 [0.3937]	70 [2.756]	-	-	-	-	0.050 [0.0019]	0.100 [0.0039]	0.100 [0.0039]

### AKM7x Motor Length Dimensional Data

Connector	No Brake (N)		
	X	Y MAX	Z MAX
	C-, G-, H-	C-, G-, H-	C-, G-, H-
Feedback Option	R-, C-, 1-, 2-, Ex, Ax, Dx, Lx, Gx	R-, C-, 1-, 2-, Ex	Ax, Dx, Lx, Gx
AKM72	164.5 [6.48]	192.5 [7.58]	201.7 [7.94]
AKM73	198.5 [7.81]	226.5 [8.92]	235.7 [9.28]
AKM74	232.5 [9.15]	260.5 [10.26]	269.7 [10.62]

Connector	Brake (2)		
	X	Z MAX	
	C-, G-, H-	C-, G-, H-	C-, G-, H-
Feedback Option	R-, C-, 1-, 2-, Ex, Ax, Dx, Lx, Gx	R-, C-, 1-, 2-, Ex	Ax, Dx, Lx, Gx
AKM72	164.5 [6.48]	234.5 [9.23]	253.3 [9.97]
AKM73	198.5 [7.81]	268.5 [10.57]	287.3 [11.31]
AKM74	232.5 [9.15]	302.5 [11.91]	321.3 [12.65]

Note 1: Dimensions are in mm [inches].

Note 2: Product designed in metric. English conversions provided for reference only.

#### Related Resources:

[Feedback Options and Specifications](#)

[Connector Options and Pinouts](#)

[Brake Option](#)

# AKM8x Series Motor Specifications

## AKM8x Performance Data – Up to 480 Vac (640 Vdc Bus) voltage

Parameters	Tol	Symbol	Units	AKM82	AKM83	AKM84
				AKM82T	AKM83T	AKM84T
Max Rated Voltage ⑩	Max	-	Vac	480	480	480
			Vdc	640	640	640
Continuous Torque for ΔT winding = 100°C ①②⑦⑧⑨	Nom	T <sub>CS</sub>	Nm	75	130	180
			lb-in	664	1151	1593
Continuous Current for ΔT winding = 100°C ①②⑦⑧⑨	Nom	I <sub>CS</sub>	A <sub>RMS</sub>	48	65	67
Continuous Torque for ΔT winding = 60°C ②	Nom	T <sub>CS</sub>	Nm	58.1	104	144
			lb-in	514	920	1274
Max Mechanical Speed ⑤	Nom	N <sub>max</sub>	rpm	3000	3000	3000
Peak Torque ①②	Nom	T <sub>p</sub>	Nm	175	299	434
			lb-in	1549	2646	3841
Peak Current	Nom	I <sub>p</sub>	A <sub>RMS</sub>	144	263.9	201
75 Vdc Rated Torque (speed) ①②⑦⑧⑨⑩		T <sub>rtd</sub>	Nm	-	-	-
			lb-in	-	-	-
Rated Speed		N <sub>rtd</sub>	rpm	-	-	-
Rated Power (speed) ①②⑦⑧⑨		P <sub>rtd</sub>	kW	-	-	-
			Hp	-	-	-
120 Vac (160 Vdc) Rated Torque (speed) ①②⑦⑧⑨⑩		T <sub>rtd</sub>	Nm	-	-	-
			lb-in	-	-	-
Rated Speed		N <sub>rtd</sub>	rpm	-	-	-
Rated Power (speed) ①②⑦⑧⑨		P <sub>rtd</sub>	kW	-	-	-
			Hp	-	-	-
240 Vac (320 Vdc) Rated Torque (speed) ①②⑦⑧⑨⑩		T <sub>rtd</sub>	Nm	-	-	-
			lb-in	-	-	-
Rated Speed		N <sub>rtd</sub>	rpm	-	-	-
Rated Power (speed) ①②⑦⑧⑨		P <sub>rtd</sub>	kW	-	-	-
			Hp	-	-	-
400 Vac (560 Vdc) Rated Torque (speed) ①②⑦⑧⑨⑩		T <sub>rtd</sub>	Nm	47.5	70	105
			lb-in	420	620	929
Rated Speed		N <sub>rtd</sub>	rpm	2500	2200	1800
Rated Power (speed) ①②⑦⑧⑨		P <sub>rtd</sub>	kW	12.4	16.1	19.8
			Hp	16.65	21.62	26.58
480 Vac (640 Vdc) Rated Torque (speed) ①②⑦⑧⑨⑩		T <sub>rtd</sub>	Nm	38	60	93
			lb-in	336	531	823
Rated Speed		N <sub>rtd</sub>	rpm	3000	2500	2000
Rated Power (speed) ①②⑦⑧⑨		P <sub>rtd</sub>	kW	11.9	15.7	19.5
			Hp	16.0	21.0	26.1

See following page for notes.

## AKM8x Performance Data – Up to 480 Vac (640 Vdc Bus) voltage (Continued)

Parameters	Tol	Symbol	Units	AKM82	AKM83	AKM84
				AKM82T	AKM83T	AKM84T
Torque Constant ①	±10%	$K_t$	Nm/A <sub>rms</sub>	1.68	2.17	2.75
			lb-in/A <sub>rms</sub>	14.9	19.2	24.3
Back EMF Constant ⑥	±10%	$K_e$	V <sub>rms</sub> /krpm	108	140	177
Motor Constant	Nom	$K_m$	N-m/√W	4.31	6.94	9.15
			lb-in/√W	38.1	61.4	81.0
Resistance (line-line) ⑥	±10%	$R_m$	ohm	0.092	0.061	0.058
Inductance (line-line)		L	mH	2.73	2.36	2.5
Inertia (includes Resolver feedback) ③		$J_m$	kg-cm <sup>2</sup>	172	334	495
			lb-in-s <sup>2</sup>	0.15	0.29	0.43
Optional Brake Inertia (additional)		$J_m$	kg-cm <sup>2</sup>	4.438	4.438	4.438
			lb-in-s <sup>2</sup>	3.930E-03	3.930E-03	3.93E-03
Weight (w/o brake) ⑧		W	kg	65	85	105
			lb	143.3	187.4	231.5
Static Friction ①⑩		$T_f$	Nm	1.7	1.8	2.30
			lb-in	15.05	15.93	20.36
Viscous Damping ①		$K_{dv}$	Nm/krpm	0.35	0.95	1.6
			lb-in/krpm	3.10	8.41	14.16
Thermal Time Constant		TCT	minutes	71	94	116
Thermal Resistance		$R_{thw-a}$	°C/W	0.225	0.203	0.183
Operating Ambient Temperature Range ⑫ ⑬ ⑭			°C	-20 to 40	-20 to 40	-20 to 40
Pole Pairs				5	5	5
Heat Sink Size				18"x18"x1/2" Aluminum Plate	18"x18"x1/2" Aluminum Plate	18"x18"x1/2" Aluminum Plate

Additional windings may exist. Please contact Kollmorgen Customer Support for further information or to request custom winding options for your application requirements.

### Notes:

- ① Motor winding temperature rise,  $\Delta T = 100^\circ \text{C}$ , at  $40^\circ \text{C}$  ambient.
- ② All data referenced to sinusoidal commutation.
- ③ Add parking brake if applicable for total inertia.
- ④ Motor with standard heat sink.
- ⑤ May be limited at some values of  $V_{bus}$ .
- ⑥ Measured at  $25^\circ \text{C}$ .
- ⑦ Brake option decreases continuous torque by 6 Nm
- ⑧ Brake option increases weight by 8.1 kg (17.8 lb).
- ⑨ Non-Resolver feedback options reduce continuous torque ratings by: AKM82 = 9 Nm, AKM83 = 6 Nm, AKM84 = 18 Nm
- ⑩ Motor with non-resolver feedback and brake options reduce continuous torque ratings by: AKM82 = 17 Nm, AKM83 = 16 Nm, AKM84 = 28 Nm
- ⑪ Motors can be operated up to 480 Vac. For performances curves at voltages, listed or unlisted, please use our online Performance Curve Generator Tool.
- ⑫ Brake option will operate in this range in a non-condensing environment. See the Brake Option section for more information.
- ⑬ "AA" or "AB" BiSS feedback lower limit is  $-15^\circ \text{C}$ ; all other feedbacks meet or exceed this range.
- ⑭ Operation ABOVE  $40^\circ \text{C}$  may be possible. Please contact Kollmorgen Customer Support with your application requirements.

### Related Resources:

- [AKM® Servo Motor Quick Guide](#) (for typical torque/speed performance)
- [Performance Curve Generator Tool](#) (generate AKM model specific performance curves)
- [Brake Option](#) (detailed brake specifications)

# AKM8x Series Motor Specifications

## AKM8x Frame with Terminal Box Dimensional Drawings

AKM 2D/3D CAD models can be found at [Kollmorgen.com/DesignTools](http://Kollmorgen.com/DesignTools)

### T-connector option

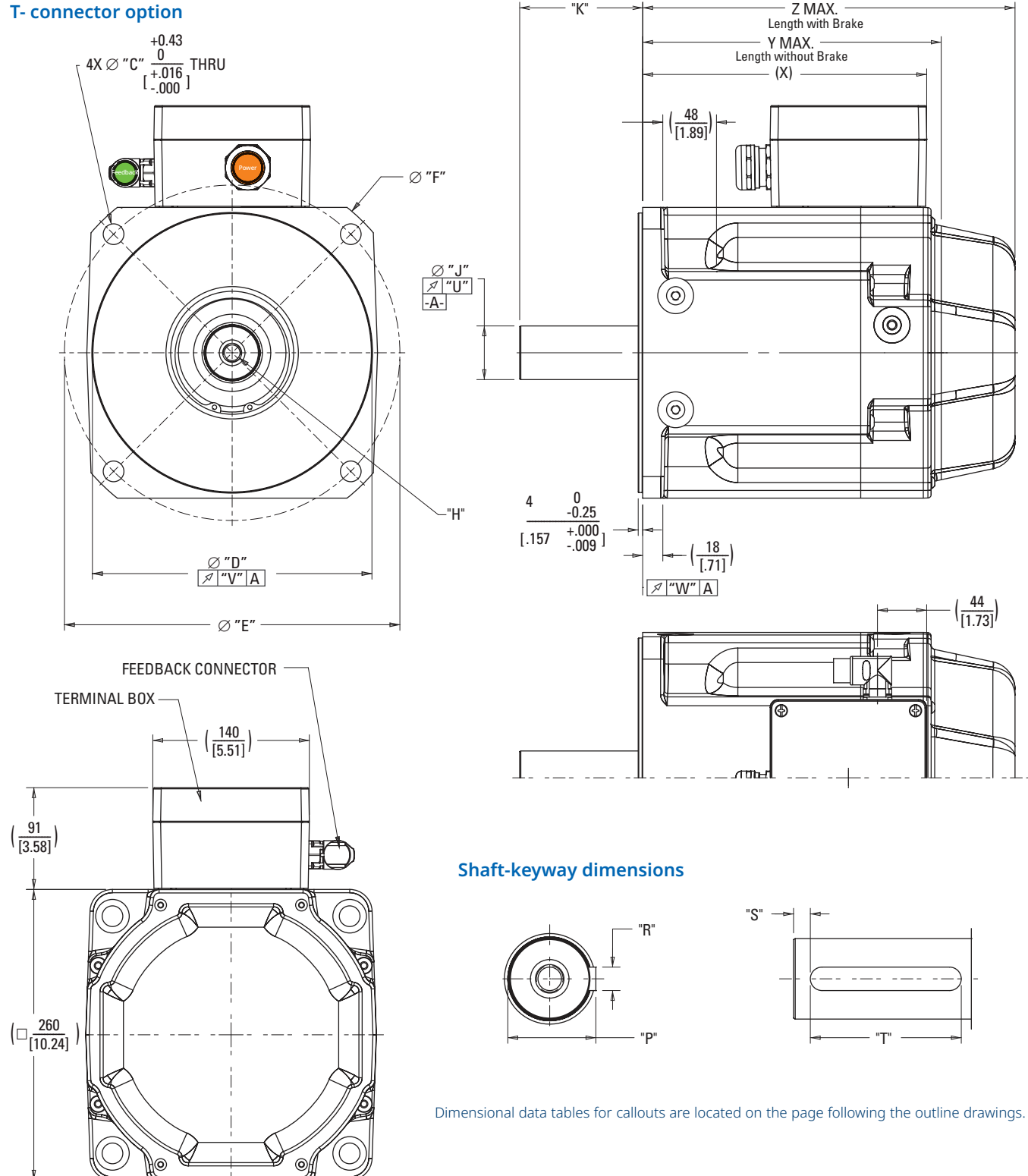

### Shaft-keyway dimensions

Dimensional data tables for callouts are located on the page following the outline drawings.

## AKM82 Frame with Rotatable IP65 Connectors Dimensional Drawings

AKM 2D/3D CAD models can be found at [Kollmorgen.com/DesignTools](http://Kollmorgen.com/DesignTools)

### H- connector option

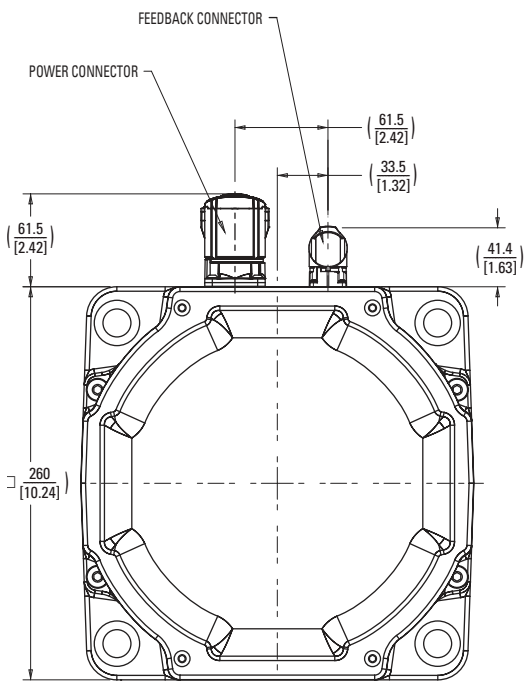
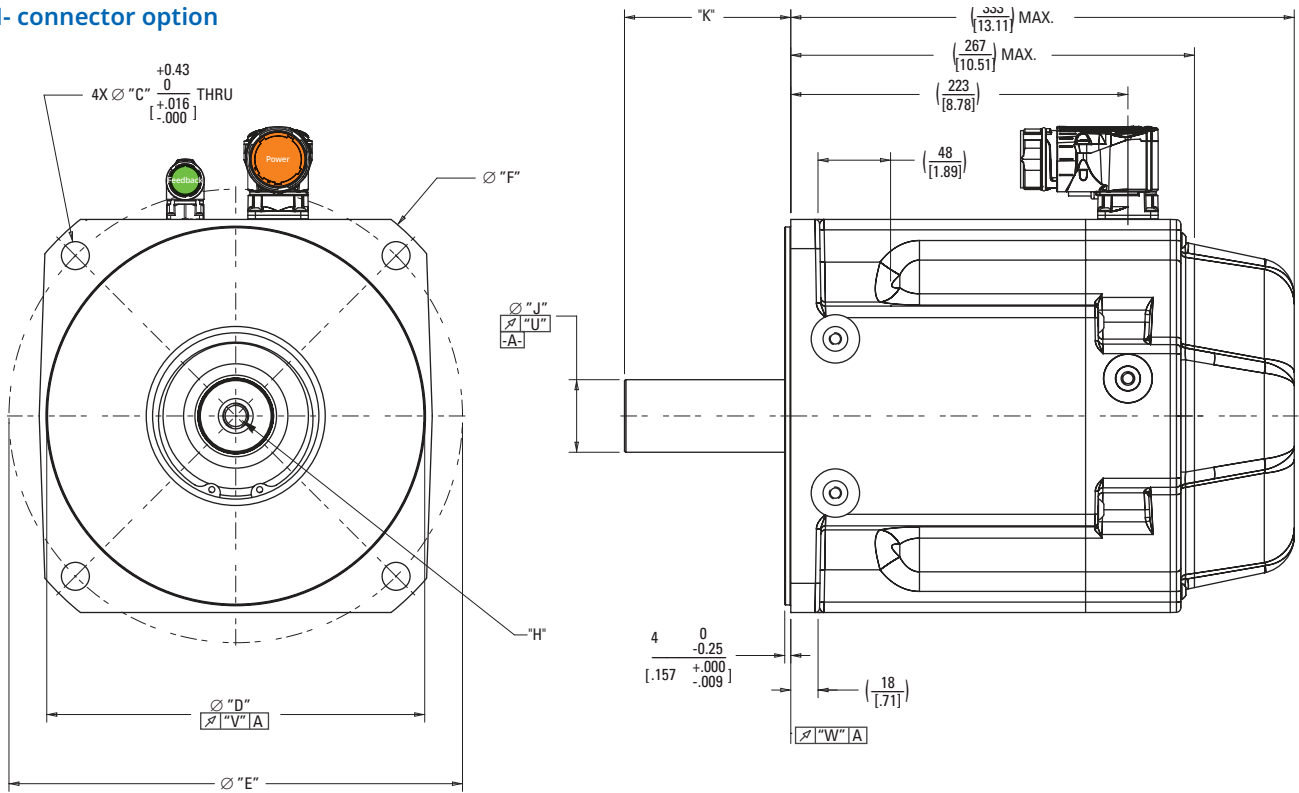

### Shaft-keyway dimensions

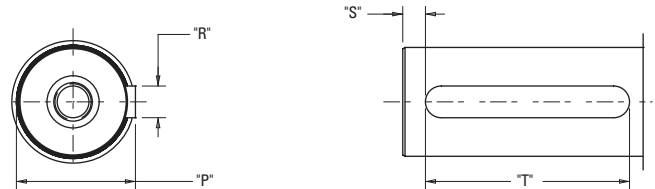

Dimensional data tables for callouts are located on the page following the outline drawings.

# AKM8x Series Motor Specifications

## AKM82 Frame Dimensional Data

### AKM8x Mounting Flange-Shaft Dimensional Data

	Mounting Flange-Shaft	Hole Diameter "C"	Pilot Diameter "D"	Bolt Circle Dia. "E"	"F"	"H"	Shaft Diameter "J"	Shaft Length "K"
	AC	18.5 [0.728]	250 [9.8425]	300 [11.811]	-	D M16 DIN 332	48 [1.8898]	110 [4.33]
	AN	18.5 [0.728]	250 [9.8425]	300 [11.811]	-	D M16 DIN 332	48 [1.8898]	110 [4.33]
	CC	14.5 [0.571]	230 [9.055]	265 [10.433]	300 [11.811]	D M16 DIN 332	48 [1.8898]	110 [4.33]
	CN	14.5 [0.571]	230 [9.055]	265 [10.433]	300 [11.811]	D M16 DIN 332	48 [1.8898]	82 [3.228]
	HC	14.5 [0.571]	230 [9.055]	265 [10.433]	300 [11.811]	D M16 DIN 332	42 [1.6535]	82 [3.228]
	HN	14.5 [0.571]	230 [9.055]	265 [10.433]	300 [11.811]	D M16 DIN 332	42 [1.6535]	82 [3.228]
	GC	18.5 [0.728]	250 [9.8425]	300 [11.811]	-	D M16 DIN 332	48 [1.8898]	82 [3.228]
	GN	18.5 [0.728]	250 [9.8425]	300 [11.811]	-	D M16 DIN 332	48 [1.8898]	82 [3.228]
REINFORCED BEARINGS	MC	18.5 [0.728]	250 [9.8425]	300 [11.811]	-	D M16 DIN 332	48 [1.8898]	110 [4.33]
	MN	18.5 [0.728]	250 [9.8425]	300 [11.811]	-	D M16 DIN 332	48 [1.8898]	110 [4.33]
	TC	14.5 [0.571]	230 [9.055]	265 [10.433]	300 [11.811]	D M16 DIN 332	48 [1.8898]	110 [4.33]
	TN	14.5 [0.571]	230 [9.055]	265 [10.433]	300 [11.811]	D M16 DIN 332	48 [1.8898]	110 [4.33]

	Mounting Flange-Shaft	Shaft Dia. w/ Key "P"	Key Width "R"	"S"	Key Length "T"	"U"	"V"	"W"
	AC	51.5 [2.028]	14 [0.5512]	10 [0.394]	90 [3.543]	0.050 [0.0019]	0.125 [0.0049]	0.125 [0.0049]
	AN	-	-	-	-	0.050 [0.0019]	0.125 [0.0049]	0.125 [0.0049]
	CC	51.5 [2.028]	14 [0.5512]	10 [0.394]	90 [3.543]	0.050 [0.0019]	0.100 [0.0039]	0.100 [0.0039]
	CN	-	-	-	-	0.050 [0.0019]	0.100 [0.0039]	0.100 [0.0039]
	HC	45 [1.7772]	12 [0.5512]	8 [0.315]	63 [2.480]	0.050 [0.0019]	0.100 [0.0039]	0.100 [0.0039]
	HN	-	-	-	-	0.050 [0.0019]	0.100 [0.0039]	0.100 [0.0039]
	GC	51.5 [2.028]	14 [0.5512]	8 [0.315]	63 [2.480]	0.050 [0.0019]	0.125 [0.0049]	0.125 [0.0049]
	GN	-	-	-	-	0.050 [0.0019]	0.125 [0.0049]	0.125 [0.0049]
REINFORCED BEARINGS	MC	51.5 [2.028]	14 [0.5512]	10 [0.394]	90 [3.543]	0.050 [0.0019]	0.125 [0.0049]	0.125 [0.0049]
	MN	-	-	-	-	0.050 [0.0019]	0.125 [0.0049]	0.125 [0.0049]
	TC	51.5 [2.028]	14 [0.5512]	10 [0.394]	90 [3.543]	0.050 [0.0019]	0.100 [0.0039]	0.100 [0.0039]
	TN	-	-	-	-	0.050 [0.0019]	0.100 [0.0039]	0.100 [0.0039]

### AKM8x Motor Length Dimensional Data

Connector	No Brake (N)		Brake (2)
	X	Y MAX	Z MAX
Feedback Option	H-, T-	H-, T-	H-, T-
AKM82 "H" Connector	223 [8.78]	267 [10.51]	333 [13.11]
AKM82 "T" TERMINAL BOX	255 [10.04]	267 [10.51]	333 [13.11]
AKM83 "T" TERMINAL BOX	335.5 [13.21]	347.5 [13.68]	413.5 [16.28]
AKM84 "T" TERMINAL BOX	416 [16.38]	428 [16.85]	494 [19.45]

Note 1: Dimensions are in mm [inches].

Note 2: Product designed in metric. English conversions provided for reference only.

#### Related Resources:

[Feedback Options and Specifications](#)

[Connector Options and Pinouts](#)

[Brake Option](#)

# Brake Option

## Failsafe, Holding Brake

The holding brake is designed to provide static holding torque to the motor shaft with the brake coil de-energized. The brake must first be released (coil energized) prior to commanding motor rotation as determined by its drop-out time. The brake is intended for holding or “parking” of a stationary motor. It is not intended for dynamic braking. There should be absolutely no motion of the rotor when power is removed from the brake coil.

### AKM Motor Brake Specifications

Motor Family	Minimum Static Torque @120°C		Weight		Power Consumption @24V, 20°C	Current @24V, 20°C	Inertia		Closing Time (engage)	Opening Time (release)	Backlash	
	Nm	lb-in	Kg	lb	Watts ±7%	ADC	kg-cm <sup>2</sup>	lb-in-sec <sup>2</sup>	msec	msec	Maximum deg.	Typical deg.
AKM1	0.41	3.63	0.19	0.42	6.3	0.27	0.0013	1.20E-06	22	45	1.15	0.53
AKM2	1.42	12.6	0.27	0.59	8.4	0.35	0.013	1.20E-05	36	45	1.01	0.46
AKM3	2.5	22.1	0.36	0.79	10.2	0.42	0.014	1.20E-05	20	50	1.01	0.46
AKM4	5.3	46.9	0.69	1.52	12.7	0.53	0.058	5.12E-05	30	75	0.81	0.37
AKM5	14.5	128	1.2	2.64	19.7	0.81	0.166	1.47E-04	30	115	0.71	0.31
AKM6	25	221	2.2	4.81	25.7	1.07	0.668	5.91E-04	40	155	0.51	0.24
AKM7	53	469	3.1	6.82	35.6	1.48	1.589	1.41E-03	70	170	0.44	0.20
AKM8	150	1330	8.1	17.8	52.3	2.04	4.438	3.93E-03	100	300	0.44	0.20

#### Notes:

1. Contamination of the motor internal compartment by oil or other foreign materials will result in failure of the brake. Check the suitability of motor sealing for the working environment.
2. Operating Voltage: 24 Vdc ± 10%.
3. Maximum backlash is calculated using worst-case tolerancing, and typical backlash is calculated using statistical tolerancing.
4. Brake Operating Temperature Range: -20C to 120C. Sub-zero temperatures present a freezing risk for condensation which could prevent correct brake operation.

# AKM Feedback Options

## AKM Servo Motor Feedback Summary with AKD Family Servo Drives

### Feedback Unit Options

Feedback Unit Options				Feedback Resolution			# of Absolute Revs.	Accuracy (± arc-mins)
Code	Designation	AKM Frame Size	Single-Turn or Multi-Turn	Device Resolution (Sin/Cos per Rev., Bits or Lines/Rev.)	AKD Internal Resolution	AKD2G Internal Resolution		
1-	Commutating Encoder	1-8	Single-Turn	1024 Lines	4,096	4,096	None	1
2-				2048 Lines	8,192	8,192		
ED		2-8		500 Lines	2,000	2,000		
EE				1000 Lines	4,000	4,000		
EF				2000 Lines	8,000	8,000		
EG				2500 Lines	10,000	10,000		
EH				5000 Lines	20,000	20,000		
EJ				10000 Lines	40,000	40,000		
EM				4096 Lines	16,384	16,384		
EN				8192 Lines	32,768	32,768		
AA				BISS B Optical Sine Encoder	2-4	Single-turn		
AB	5-8	Multi-turn	4,096					
C-	SFD Smart Feedback Device	1	Single-turn	24-Bits	24-Bits	24-Bits	1	15
		2-4						8
		5-8						9
CA	SFD3 Smart Feedback Device, Gen. 3	1	Single-turn	24-Bits	24-Bits	24-Bits	1	15
		2-4						8
		5-6						9
CB	SFD-M Smart Feedback Device, Multi-turn	2-6	Multi-turn	24-Bits	24-Bits	24-Bits	65,536	1
GE	HIPERFACE DSL® Optical Encoder	2-6	Single-turn	18-Bits	18-Bits	18-Bits	1	1.33
GF			Multi-turn				4,096	
GA/GJ*	HIPERFACE Optical Sin/Cos Encoder	2-8	Single-turn	128 Sin/Cos	23-Bits	31-Bits	1	1.33
GB/GK*			Multi-turn				4,096	
GP**	HIPERFACE Capacitive Encoder	1	Single-turn	16 Sin/Cos	20-Bits	28-Bits	1	4.8
GR**			Multi-turn				4,096	
DA	EnDat® 2.2/01 Optical Sine Encoder	2-4	Single-turn	512 Sin/Cos	25-Bits	32-Bits	1	1
DB		5-8		2048 Sin/Cos	27-Bits			0.333
		2-4	Multi-turn	512 Sin/Cos	25-Bits		4,096	1
5-8		2048 Sin/Cos		27-Bits	0.333			
LA	EnDat® 2.2/22 Inductive Encoder	2-3	Single-turn	18-Bits	18-Bits	18-Bits	1	4.67
LB		4-8		19-Bits	19-Bits			19-Bits
		2-3	Multi-turn	18-Bits	18-Bits	19-Bits	4,096	4.67
4-8		19-Bits		19-Bits	3			
R-	Resolver Inductive Encoder	1	Single-Turn	1 pole pair (16-Bits)	16-Bits	16-Bits	1	15
		2-4						10
		5-8						9

\*ServoStar (Sxxx)/AKD mapped respectively

\*\*AKD mapped ONLY

# AKM Feedback Option Motor Connector Availability

## Feedback and Connector Availability

AKM1		C	9	M	P	Y
Feedback Code	R-	•		•		•
	1-, 2-	•		•		•
	C-	•		•	•	•
	CA		•			
	GP, GR	•				•

AKM2		B	C	9	G	M	P
Feedback Code	R-	•	•		•	•	
	1-, 2-	•	•		•	•	
	Ex	•	•		•	•	
	AA, AB	•	•		•	•	
	C-	•	•	•	•	•	•
	CA,CB			•			
	DA,DB	•	•		•	•	
	LA, LB	•	•		•	•	
	GA, GB	•			•		
	GE, GF			•			
	GJ, GK	•			•		

AKM3		C	9	G	M	P
Feedback Code	R-	•		•	•	
	1-, 2-	•		•	•	
	Ex	•		•	•	
	AA, AB	•		•	•	
	C-	•	•	•	•	•
	CA,CB		•			
	DA,DB	•		•	•	
	LA, LB	•		•	•	
	GA, GB	•		•		
	GE, GF		•			
	GJ, GK	•		•		

AKM4		C	9	G	M	P
Feedback Code	R-	•		•	•	
	1-, 2-	•		•	•	
	Ex	•		•	•	
	AA, AB	•		•	•	
	C-	•	•	•	•	•
	CA,CB		•			
	DA,DB	•		•	•	
	LA, LB	•		•	•	
	GA, GB	•		•		
	GE, GF		•			
	GJ, GK	•		•		

AKM5		C	9	G
Feedback Code	R-	•		•
	1-, 2-	•		•
	Ex	•		•
	AA, AB	•		•
	C-	•		•
	CA,CB		•	
	DA,DB	•		•
	LA, LB	•		•
	GA, GB	•		•
	GE, GF		•	
	GJ, GK	•		•

AKM6		C	9	G
Feedback Code	R-	•		•
	1-, 2-	•		•
	Ex	•		•
	AA, AB	•		•
	C-	•		•
	CA,CB		•	
	DA,DB	•		•
	LA, LB	•		•
	GA, GB	•		•
	GE, GF		•	
	GJ, GK	•		•

AKM7		C	G	H*
Feedback Code	R-	•	•	•
	1-, 2-	•	•	•
	Ex	•	•	•
	AA, AB	•	•	•
	C-	•	•	•
	DA,DB	•	•	•
	LA, LB	•	•	•
	GA, GB	•	•	•
	GJ, GK	•	•	•

AKM8		H*	T
Feedback Code	R-	•	•
	1-, 2-	•	•
	Ex	•	•
	AA, AB	•	•
	C-	•	•
	DA,DB	•	•
	LA, LB	•	•
	GJ, GK	•	•

\*AKM74Q Only

\*AKM82T Only

# AKM Feedback Options

## AKM Feedback Type Specifications

### Kollmorgen Smart Feedback Device, Multi-turn (SFD-M) (CB)

The SFD-M Feedback uses a single motor cable, requiring just one cable between the drive and motor.

The feedback has both power and communication on a single wire pair, reducing overall wiring costs. SFD-M offers 24-bit absolute single-turn resolution, batteryless 16-bit (65,536) multi-turn absolute revolutions and an absolute angular accuracy of +/- 1 arc-min.

In addition, the device includes onboard memory for an electronic motor datasheet which enables device auto-recognition for faster setup and commissioning when paired with any Kollmorgen KED, AKD or AKD2G drive.

#### Angle Measurement:

Single-Turn Resolution:  $2^{24} = 16,777,216$  counts per rev

Multi-Turn Absolute Range:  $2^{16} = 65,536$  absolute revolutions\* (batteryless)

Accuracy: < +/- 1 arc-min typical 25° C  
< +/- 3 arc-min worst case

Electrical Noise: <  $2^{-22}$  Rev rms at full bandwidth

Bandwidth: > 2 kHz at -3 dB

> 1 kHz at -45° phase lag

Max Continuous Speed: 10,000 RPM

Velocity Ripple: < 1% p-p (typical)

Velocity Noise: < 0.3 RPM rms at full bandwidth

#### Power Supply:

Input Voltage: 7 V - 12 V accepted (at motor terminals)

Input current maximum: 140 mA DC

#### Digital Communications:

Baud rate: 2.5 MBaud

Signaling: RS-485 differential using differential Manchester encoding

Update period: New position sample every 51.2  $\mu$ s

Error detection: 5-bit CRC and running parity check

#### Environmental:

Feedback Operating Temperature: -40 to 120° C

Humidity: 10% to 90% non-condensing

Vibration Resistance: 30g (294 m/s<sup>2</sup>) @ 55-2000 Hz (EN60068-2-6)

Shock Resistance: 100g (981 m/s<sup>2</sup>) @ 6 ms (EN60068-2-27)

\* When paired with AKD, this is limited to 4096 absolute revolutions (12-bits)

### Kollmorgen Smart Feedback Device, Gen 3 (SFD3) (CA)

Kollmorgen's proprietary SFD3 Feedback uses a single motor cable, requiring just one cable between the drive and motor. The feedback has both power and communication on a single wire pair, reducing overall wiring costs. In addition, the device includes onboard memory for an electronic motor datasheet.

#### Angle Measurement:

Resolution:  $2^{24} = 16,777,216$  counts per rev

Accuracy: <  $\pm 0.75$  arc-min electrical + sensor error

Size 10 sensor error:  $\pm 15$  arc-min net (AKM 1)

Size 15 sensor error:  $\pm 8$  arc-min net (AKM 2-4)

Size 21 sensor error:  $\pm 9$  arc-min net (AKM 5-8)

Electrical Noise: <  $2^{-17}$  Rev rms at full bandwidth

Bandwidth: > 2000 Hz at -3 dB

> 1000 Hz at -45° phase lag

Max Continuous Speed: 20,000 RPM

Velocity Ripple: < 0.2% p-p electronics only

Size 10 sensor: < 3.0% p-p net (AKM 1)

Size 15 sensor: < 2.0% p-p net (AKM 2-4)

Size 21 sensor: < 2.5% p-p net (AKM 5-6)

Velocity Noise: < 4 RPM rms at full bandwidth

#### Environmental:

Operating ambient: -20 to 120° C

Humidity: 10% to 90% non-condensing

Storage temperature: -40 to 135° C

#### Digital Communications:

Baud Rate: 2.5 MBaud

Signaling: RS-485 differential using differential Manchester encoding

Update Period: Once every 51.2  $\mu$ s new position sample

Error Detection: 5 bit CRC and running parity check

#### Power Supply:

Supply at Drive: 7 to 12 V

Supply at SFD in motor: 7 to 12 V

Nominal Supply Current: 65 mA at 10 V

Worst Case Supply: 110 mA at 10 V

Cable Resistance: Com+, Com- net < 10 Ohm net

# AKM Feedback Type Specifications

## Kollmorgen Smart Feedback Device (SFD) (C-)

The SFD Feedback communicates with the drive over a four-wire interface. Two wires supply up to +5V power at <150 mA and the second pair is an RS-485 digital communications link. The device includes EEPROM memory to save motor parameters.

### Angle Measurement:

Resolution:  $2^{24} = 16,777,216$  counts per rev  
 Accuracy:  $< \pm 0.75$  arc-min electrical + sensor error  
 Size 10 sensor:  $\pm 15$  arc-min net (AKM 1)  
 Size 15 sensor  $\pm 8$  arc-min net (AKM 2,3,4)  
 Size 21 sensor  $\pm 9$  arc-min net (AKM 5,6,7)  
 Electrical Noise:  $< 2^{-17}$  Rev rms at full bandwidth  
 Bandwidth:  $> 2000$  Hz at -3 dB  
                    $> 1000$  Hz at -45° phase lag  
 Max Continuous Speed:  $> 20,000$  RPM  
 Velocity Ripple:  $< 0.2\%$  p-p electronics only  
 Size 10 sensor  $< 3.0\%$  p-p net (AKM 1)  
 Size 15 sensor  $< 2.0\%$  p-p net (AKM 2-4)  
 Size 21 sensor  $< 2.5\%$  p-p net (AKM 5-8)  
 Velocity Noise:  $< 4$  RPM rms at full bandwidth

### Digital Communications:

Baud Rate: 2.5 MBaud  
 Signaling: RS-485 differential, 8 bit data with odd parity compatible with standard UARTS  
 Update Period: Once every 51.2 uSec new position sample  
 Error Detection: 5 bit CRC in addition to parity check  
 EEPROM Memory: Does a data dump when the unit powers up.

### Power Supply:

Supply at Drive:  $5.0\text{ V} \pm 0.25\text{ V}$  ( $\pm 5\%$ )  
 Supply at SFD in motor: 4.25 V to 5.25 V  
 Nominal Supply Current: 120 mA  
 Worst Case Supply: 150 mA  
 Cable Resistance: +5V, Rtn:  $< 3.3$  Ohm net

### Environmental:

Feedback Operating Temperature: -55 to 155° C  
 Humidity: 10% to 90% non-condensing

## Resolver (Feedback)

Resolver Data	Units	AKM1	AKM2-4	AKM 5-8
		1 Speed	1 Speed	1 Speed
Input Voltage	Vrms (tolerance)	7 ( $\pm 10\%$ )	8 ( $\pm 5\%$ )	8 ( $\pm 5\%$ )
	KHz (tolerance)	10 ( $\pm 5\%$ )	8 ( $\pm 1\%$ )	8 ( $\pm 1\%$ )
Input Current Max.	mA MAX.	30	50	46
Transformation Ratio	$\pm 10\%$	0.5	0.5	0.5
Null Voltage	mVrms MAX.	50	30	30
Max. Error (pk-pk)	MINS.	30	20	18
Phase Shift	Degrees	-9	0	0
Feedback Operating Temperature	°C	-55° to 155°	-55° to 155°	-55° to 155°
Rotor Inertia Max.	kg-cm <sup>2</sup>	0.002	0.046	0.497

### Resolver Alignment

With positive DC current into phase W and out of phase V (U floats) the resolver is aligned to electrical  $\pm 5$  counts. ie. Voltage S1-S3 set to null voltage S2-S4 max in phase with reference (R1-R2).

### Resolver Winding Configuration

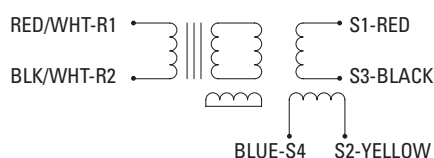

$$E_{R1-R2} = E \sin(\omega T)$$

$$E_{S1-S3} = K E_{R1-R2} \sin \theta$$

$$E_{S2-S4} = K E_{R1-R2} \cos \theta$$

# AKM Feedback Options

## AKM Feedback Type Specifications

### HIPERFACE Options

#### HIPERFACE DSL® (GE / GF)

Type		Single-Turn "GE"	Multi-Turn "GF"
Frame Size		AKM2-6	AKM 2-6
Resolution per revolution	bits	18	18
Input Voltage	Vdc	7 to 12	7 to 12
Current Consumption	mA MAX.	150	150
Feedback Operating Temperature	°C MIN./MAX.	-20/115	-20/115
Inertia	kg-cm <sup>2</sup>	0.0045	0.0045
Output Interface		Hiperface DSL	
Manufacturer Product Type		EKS36	EKM36

#### HIPERFACE Absolute Sin/Cos Encoder (GA / GJ, GB / GK)

Type		Single-Turn "GA/GJ"	Multi-Turn "GB/GK"
Frame Size		AKM2-8	AKM 2-8
Sin/Cos period per revolution	-	128	128
Input Voltage	Vdc	7 to 12	7 to 12
Current Consumption	mA Typical	60	60
Feedback Operating Temperature	°C MIN./MAX.	-20/110	-20/110
Inertia	kg-cm <sup>2</sup>	0.0045	0.0045
Output Interface		Absolute Hiperface Sin/Cos Encoder	
Manufacturer Product Type		SKS36	SKM36

\*GA/GB Feedbacks are "mapped" for ServoStar (Sxxx) Series drives

\*\*GJ/GK Feedbacks are "mapped" for AKD/AKD2G Series drives.

#### HIPERFACE Capacitive Encoder (GP / GR)

Type		Single-Turn "GP"	Multi-Turn "GR"
Frame Size		AKM1	AKM1
Sin/Cos period per revolution	-	16	16
Input Voltage	Vdc	7 to 12	7 to 12
Current Consumption	mA MAX.	50	50
Feedback Operating Temperature	°C MIN./MAX.	-40/115	-20/115
Inertia	kg-cm <sup>2</sup>	0.001	0.001
Output Interface		Capacitive Hiperface Encoder	
Manufacturer Product Type		SEK34	SEL34

# AKM Feedback Type Specifications

## Absolute Digital Encoder Options

### EnDat Inductive (LA/LB)

Type		Single-Turn "LA"		Multi-Turn "LB"	
Frame Size		AKM2-3	AKM 4-8	AKM2-3	AKM 4-8
Sin/Cos period per revolution	-	16	32	16	32
Input Voltage	Vdc	4.75 to 10	4.75 to 10	4.75 to 10	4.75 to 10
Current Consumption	mA Typical, at 5V	85 (no load)	85 (no load)	100	102 (no load)
Feedback Operating Temperature	°C MIN./MAX.	-40/115	-20/115	-40/115	-20/115
Inertia	kg-cm <sup>2</sup>	0.002	0.021	0.002	0.021
Output Interface		HEIDENHAIN EnDat 2.1/01			
Vibration Resistance – EN 60068-2-6	g [m/s <sup>2</sup> ]	Stator ≤41 g [400 m/s <sup>2</sup> ] – Rotor ≤61 g [600 m/s <sup>2</sup> ] – 55 to 2000 Hz			
Shock Resistance – EN 60068-2-27	g [m/s <sup>2</sup> ]	≤100 g [981 m/s <sup>2</sup> ] – 6 ms			
Manufacturer Product Type		ECI1118	ECI1319	EQI1130	EQI1331

Encoder Alignment: With positive DC current into phase W and out of phase V (U floats) the encoder is aligned to ±3 electrical degrees.

### EnDat Optical (DA / DB)

Type		Single-Turn "DA"		Multi-Turn "DB"	
Frame Size		AKM2-4	AKM 5-8	AKM2-4	AKM 5-8
Cycles per Revolution (# of abs. revs.)	-	512 (1)	2048 (1)	512 (4096)	2048 (4096)
Input Voltage	Vdc	3.6 to 14	3.6 to 14	3.6 to 14	3.6 to 14
Current Consumption	mA Typical	85 (no load)	85 (no load)	105 (no load)	105 (no load)
Feedback Operating Temperature	°C MIN./MAX.	-40/115	-40/115	-40/115	-40/115
Inertia	kg-cm <sup>2</sup>	0.04	0.026	0.04	0.026
Output Interface		HEIDENHAIN EnDat 2.2/01			
Manufacturer Product Type		ECN1113	ECN1313	EQN1125	EQN1325

Encoder Alignment: With positive DC current into phase W and out of phase V (U floats) the encoder is aligned to ±1 electrical degree.

### BiSS Optical (AA / AB)

Type		Single-Turn "AA"		Multi-Turn "AB"	
Frame Size		AKM2-4	AKM 5-8	AKM2-4	AKM 5-8
Cycles per Revolution (# of abs. revs.)	-	2048 (1)	2048 (1)	2048 (4096)	2048 (4096)
Input Voltage	Vdc (tolerance)	5 (-5%/+10%)	5 (± 10%)	5 (-5%/+10%)	5 (± 10%)
Current Consumption	mA Typical	100 (without load)	100 (without load)	150 (without load)	100 (without load)
Feedback Operating Temperature	°C MIN./MAX.	-15/120	-15/120	-15/120	-15/120
Inertia	kg-cm <sup>2</sup>	0.025	0.038	0.025	0.038
Output Interface		BiSS B			
Manufacturer Product Type		AD34	AD58	AD34	AD58

Encoder Alignment: With positive DC current into phase W and out of phase V (U floats) the encoder is aligned to ±1 electrical degree.

# AKM Feedback Options

## AKM Feedback Type Specifications

### Commutating Encoder Option

#### Commutating Encoder (2-)

Parameter	Units	1-	2-	ED	EE	EF	EF	EG	EM	EH	EN	EJ
Frame Size		AKM1-8	AKM1-8	AKM2-8	AKM2-8	AKM2-4	AKM5-8	AKM2-8	AKM2-8	AKM2-8	AKM2-8	AKM2-8
Input Voltage	Vdc ±10%	5										
Output Data	-	TTL Differential Line Driver (Sink/Source 20mA MAX.)										
Line Count per revolution	-	1,024	2,048	500	1,000	2,000	2,000	2,500	4,096	5,000	8,192	10,000
Frequency Response	KHz	200							500		1,000	
Max. Speed	RPM	12,000	12,000	12,000	12,000	12,000	7,500	12,000	7,324	8,000	3,662	3,000
Min. Edge Separation of Incremental Channel	°e MIN.	45										
Index to U Comm Channel	-	±1°m Index Center to U Falling Edge										
Index Pulse Width	-	Gated With B Low										
Incremental Channel Accuracy	-	±1 Arc Min. Max. Edge to Edge										
Max. Acceleration	Rad/s <sup>2</sup>	100,000										
Feedback Operating Temperature	°C	-20 to 120										
Storage Temperature	°C	-25 to 120										

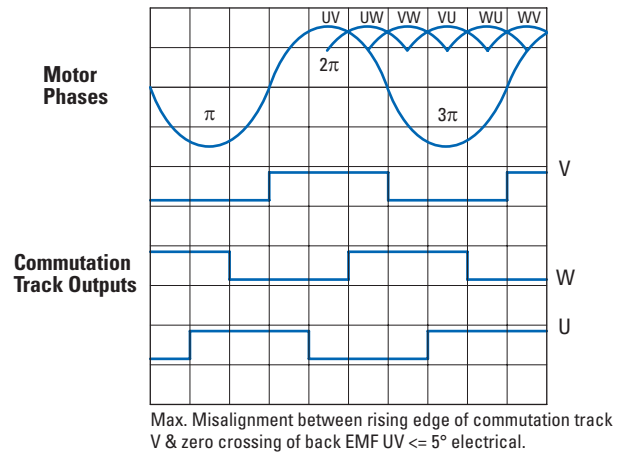
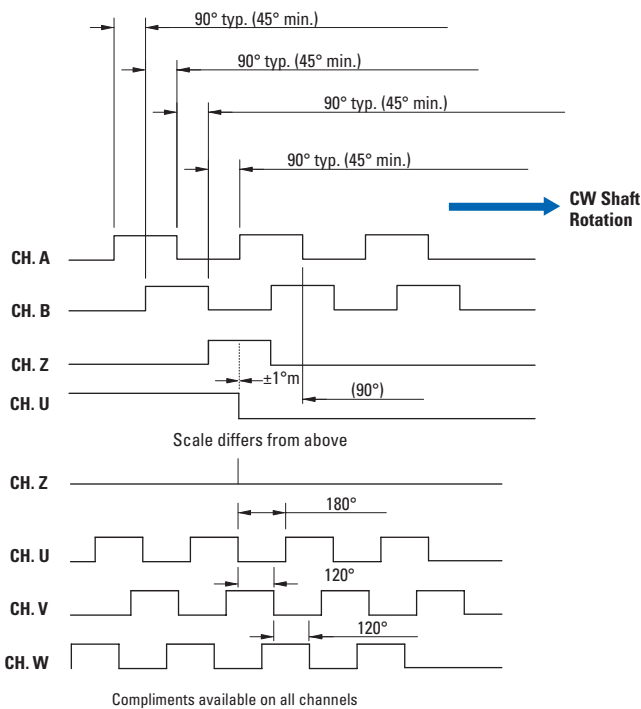

#### Motor Connections

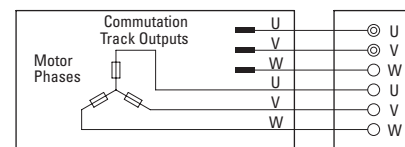

Output Comm: Open Collector W 2.2 k OHMS  
External Pull Ups  
(SINK 8 mA MAX.)

# AKM<sup>®</sup> Servo Motor Connector Options

## Connector Options

Code	Thermal Sensor*	Used with	IP Rating**	Connection type	Description
B	PTC	AKM2	IP65	2 SpeedTec Ready connectors, size 1.0 (M23)	Angled, rotatable, mounted on motor
C	PTC	AKM1-AKM2	IP65	2 SpeedTec Ready connectors, size 1.0 (M23)	On 0.5m cable
C	PTC	AKM3-AKM7	IP65	2 SpeedTec Ready connectors, size 1.0 (M23)	Angled, rotatable, mounted on motor
9	PT1000	AKM1	IP65	1 hybrid itec connector	Rotatable, mounted on motor
9	PT1000	AKM2-AKM6	IP65	1 SpeedTec Ready connector, size 1.0 (M23)	Angled, rotatable, mounted on motor
G	PTC	AKM2-AKM7	IP67	2 SpeedTec Ready connectors, size 1.0 (M23)	Straight, mounted on motor
H	PTC	AKM7 & AKM82T	IP65	1 feedback threaded connector, size 1.0 (M23) 1 power threaded connector, size 1.5 (M40)	Angled, rotatable, mounted on motor
M	PTC	AKM1-AKM4	IP20	2 Molex connectors, I <sub>c</sub> < 6 A	On 0.5m cable
P	PTC	AKM1-AKM4	IP20	1 Molex connector, I <sub>c</sub> < 6 A	On 0.5m cable
T	PTC	AKM8	IP65	1 terminal box for power 1 feedback threaded connector, size 1.0 (M23)	Mounted on motor
Y	PTC	AKM1	IP65	1 ytec connector	Rotatable, mounted on motor

NOTE: These connector options are only valid for the "00" or "01" Customization/Seal Option variants. Stainless Steel Hummel connectors are used for AKM Washdown (OW) and AKM Food Grade (OF) variants.

\*For Thermal Device Curves, reference see the Thermal Sensor Protective Devices page.

\*\*IP ratings shown apply ONLY to the connector and the connector base/bushing on motor.

## Feedback and Connector Availability

AKM1		C	9	M	P	Y
Connector Code	Feedback Code					
R-		•		•		•
1-, 2-		•		•		•
C-		•		•	•	•
CA			•			
GP, GR		•				•

AKM2		B	C	D	9	G	M	P
Connector Code	Feedback Code							
R-		•	•			•	•	
1-, 2-		•	•			•	•	
Ex		•	•			•	•	
AA, AB		•	•			•	•	
C-		•	•	•		•	•	•
CA,CB					•			
DA,DB		•	•			•	•	
LA, LB		•	•			•	•	
GA, GB		•				•		
GE, GF					•			
GJ, GK		•				•		

AKM3-4		C	D	9	G	M	P
Connector Code	Feedback Code						
R-		•			•	•	
1-, 2-		•			•	•	
Ex		•			•	•	
AA, AB		•			•	•	
C-		•	•		•	•	•
CA,CB				•			
DA,DB		•			•	•	
LA, LB		•			•	•	
GA, GB		•			•		
GE, GF				•			
GJ, GK		•			•		

AKM5-6		C	9	G
Connector Code	Feedback Code			
R-		•		•
1-, 2-		•		•
Ex		•		•
AA, AB		•		•
C-		•		•
CA,CB			•	
DA,DB		•		•
LA, LB		•		•
GA, GB		•		•
GE, GF			•	
GJ, GK		•		•

AKM7		C	G	H*
Connector Code	Feedback Code			
R-		•	•	•
1-, 2-		•	•	•
Ex		•	•	•
AA, AB		•	•	•
C-		•	•	•
DA,DB		•	•	•
LA, LB		•	•	•
GA, GB		•	•	•
GJ, GK		•	•	•

\*AKM74Q Only

AKM8		H*	T
Connector Code	Feedback Code		
R-		•	•
1-, 2-		•	•
Ex		•	•
AA, AB		•	•
C-		•	•
DA,DB		•	•
LA, LB		•	•
GA, GB		•	•
GJ, GK		•	•

\*AKM82T Only

# AKM® Servo Motor Connector Pinouts

## Dual Cable Options – Power & Feedback

### B, C, G, H, & T Power Connector Pinouts

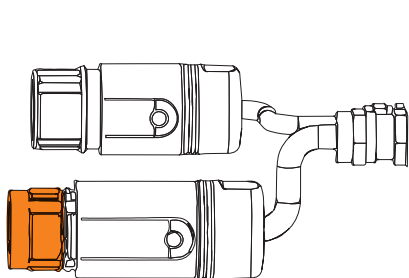

**C- Connectors (AKM1 & AKM2 Only)**  
Connector Part Number: BKUA-199-NN-00-11-0200-000

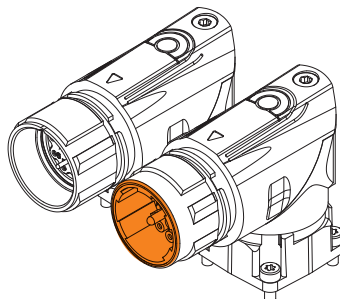

**B- Connectors (AKM2 Only)**  
**C- Connectors (AKM3-7)**

Connector Part Number: BEDC-110-NN-00-00-1216-000

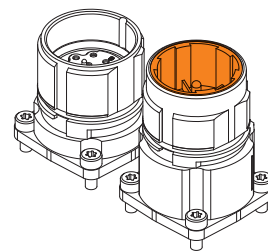

**G- Connectors (AKM2 - AKM7)**  
Connector Part Number: BEGA-120-NN-00-00-0200-000

### B-, C- & G- Power Connector Pinout

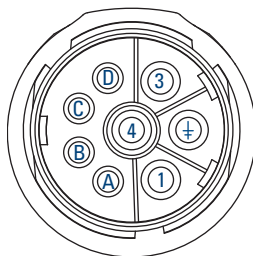

Pin	Function
1	U
⌘	PE
3	W
4	V
A	Brake +
B	Brake -
C	N/C
D	N/C

### H- Connector Pinout

(AKM7 & AKM82T Only)

Connector Part Number: CEDE-270-NN-00-00-0051-000

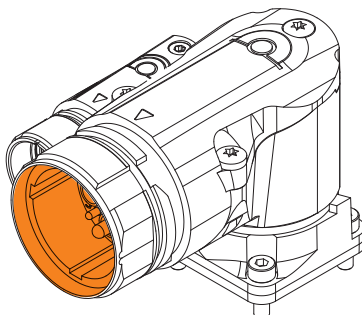

**H- Connectors**

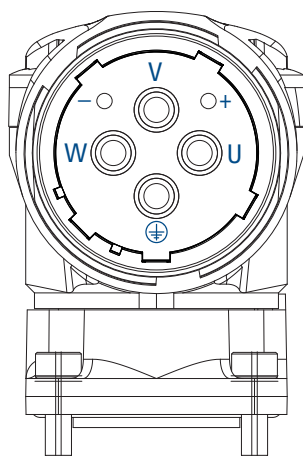

Pin	Function
U	U
⌘	PE
W	W
V	V
+	Brake +
-	Brake -

**Power Connector (View Facing Front)**

### T- Connector (AKM8 Only)

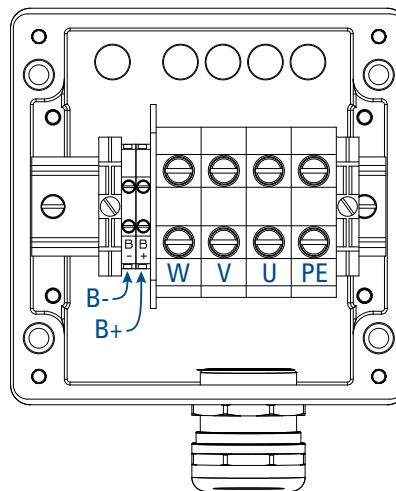
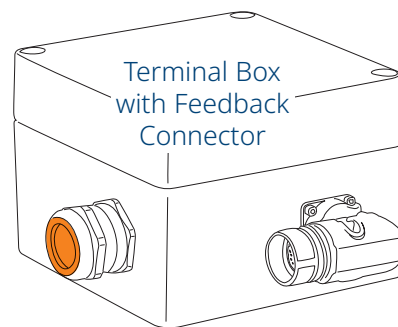

Clamp	Function
U	U
PE	PE
W	W
V	V
B+	Brake +
B-	Brake -

Note: The connector part numbers given are only valid for the "00" and "01" customization/seal option variants. For mating connector selection, please work with TE Connectivity to select the proper option based on your cable design (cable diameter and conductor size). Pinout still valid for AKM Washdown "0W" and AKM Food Grade "0F" Stainless Steel Hummel connector variants.

# Dual Cable Options – Power & Feedback

## B, C, G, H, & T Feedback Connector Pinouts

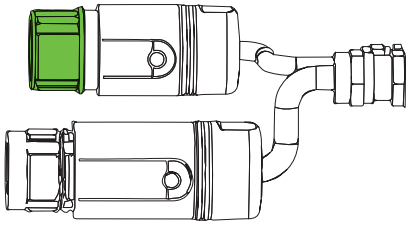

C- Connectors (AKM1 & AKM2 Only)

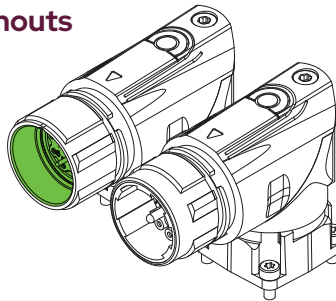

B- Connectors (AKM2 Only)  
C- Connectors (AKM3-7)

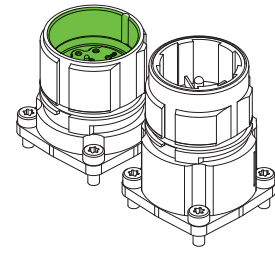

G- Connectors (AKM2 - AKM7)

Connector Part Number:

AKUA-012-NN-00-09-0200-000  
(For AKM1 & 2, "C- Connector")

AEDC-110-NN-00-00-1215-000  
(For AKM2 "B- Connector", AKM3-7, "C- Connector" and AKM7 & AKM8 "H- Connector")

AEGA-110-NN-00-00-0201-000  
(For AKM2-7 "G- Connector")

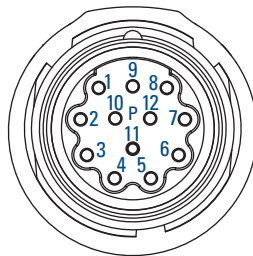

### SFD2

Pin	Function
1	SFD +5V
2	SFD +5V RTN
3	SFD COM-
4	SFD COM+
5	SFD COM Shield (AKM 1, 2)
6	N/C
7	N/C
8	N/C
9	N/C
10	N/C
11	N/C
12	N/C

### Resolver

Pin	Function
1	N/C
2	Thermal Sensor +
3	S4 COS -
4	S3 SIN -
5	R2 REF -
6	Thermal Sensor -
7	S2 COS +
8	S1 SIN +
9	R1 REF +
10	N/C
11	N/C
12	N/C

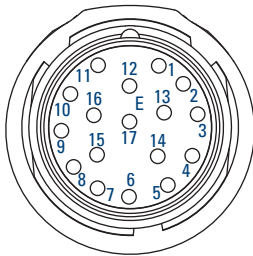

### Commutating Encoder

Pin	Function
1	B
2	$\bar{B}$
3	A
4	$\bar{A}$
5	Z
6	$\bar{Z}$
7	GND
8	Thermal Sensor +
9	Thermal Sensor -
10	Vcc
11	N/C
12	N/C
13	N/C
14	N/C
15	U
16	V
17	W

Connector Part Number:

AKUA-015-NN-00-09-0200-000  
(For AKM1 & 2, "C- Connector")

AEDC-139-NN-00-00-1215-000  
(For AKM2 "B- Connector", AKM3-7, "C- Connector" and AKM7 & AKM8 "H- Connector")

AEGA-139-NN-00-00-0201-000  
(For AKM2-7 "G- Connector")

### EnDat<sup>®</sup>/BiSS

Pin	Function
1	B -
2	GND
3	A -
4	Vcc
5	DATA
6	N/C
7	Thermal Sensor +
8	Clock
9	B +
10	Un Sense (Common)
11	A +
12	Up Sense (VCC)
13	$\bar{DATA}$
14	Thermal Sensor -
15	$\bar{Clock}$
16	N/C
17	N/C

### HIPERFACE<sup>®</sup> Analog

Pin	Function
1	SIN +
2	GND
3	COS +
4	Vcc
5	Data
6	N/C
7	Thermal Sensor +
8	N/C
9	REF SIN
10	N/C
11	REF COS
12	N/C
13	Data
14	Thermal Sensor -
15	N/C
16	N/C
17	N/C

## H- Connectors (AKM74Q - AKM82T Only)

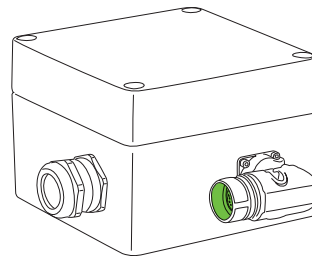
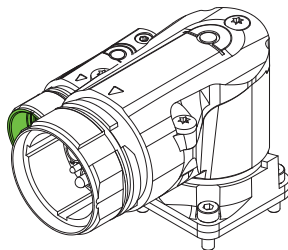

T- Connector  
(AKM8 Only)

Note: The connector part numbers given are only valid for the "00" and "01" customization/seal option variants. For mating connector selection, please work with TE Connectivity to select the proper option based on your cable design (cable diameter and conductor size). Pinout still valid for AKM Washdown "0W" and AKM Food Grade "0F" Stainless Steel Hummel connector variants.

# AKM® Servo Motor Connector Pinouts

## Dual Cable Options – Power & Feedback

ytec® - Y- Connector Pinout – AKM1 only

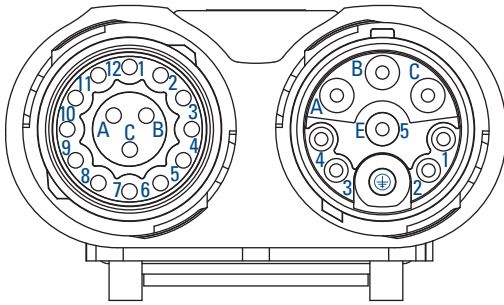

Feedback

Power + Brake

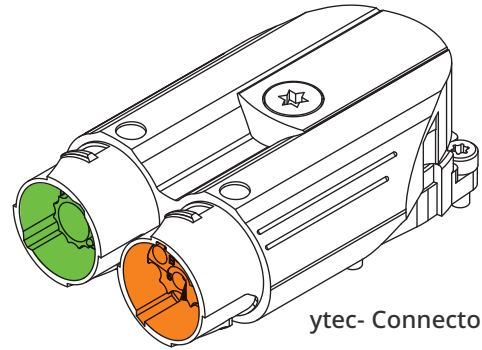

ytec- Connector

### Power Connector

Pin	Function
1	BR+
2	BR-
3	N/C
4	N/C
5/E	N/C
A	Phase U
B	Phase W
C	Phase V
⊕	PE

Connector Part Number: See Options for Commutating Encoder or SFD2/Resolver/ HIPERFACE

### Commutating Encoder

Pin	Function
1	B
2	$\bar{B}$
3	A
4	$\bar{A}$
5	Z
6	$\bar{Z}$
7	GND
8	Thermal Sensor +
9	Thermal Sensor -
10	Vcc
11	N/C
12	N/C
A	U
B	V
C	W

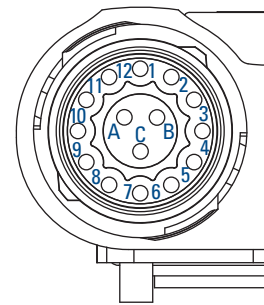

Connector Part Number:  
EEDA-103-NN-00-00-0001-000

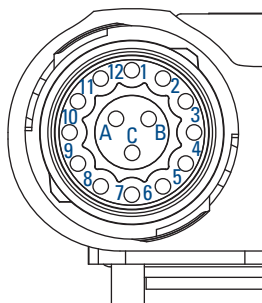

### SFD2

Pin	Function
1	SFD +5 V
2	SFD +5 V RTN
3	SFD COM-
4	SFD COM+
5	N/C
6	N/C
7	N/C
8	N/C
9	N/C
10	N/C
11	N/C
12	N/C

### Resolver

Pin	Function
1	N/C
2	Thermal Sensor +
3	S4 COS -
4	S3 SIN -
5	R2 REF -
6	Thermal Sensor -
7	S2 COS +
8	S1 SIN +
9	R1 REF +
10	N/C
11	N/C
12	N/C

### HIPERFACE® Analog

Pin	Function
1	Thermal Sensor +
2	Thermal Sensor -
3	N/C
4	REF SIN
5	REF COS
6	Data +
7	Data -
8	SIN +
9	COS +
10	Vcc
11	GND
12	N/C

Connector Part Number: EEDA-101-NN-00-00-0001-000

Note: The connector part numbers given are only valid for the "00" and "01" customization/seal option variants. For mating connector selection, please work with TE Connectivity to select the proper option based on your cable design (cable diameter and conductor size). Pinout still valid for AKM Washdown "0W" and AKM Food Grade "0F" Stainless Steel Hummel connector variants.

# Hybrid Single Cable Options – Power & Feedback

## 9-, and E Hybrid Connector Pinouts

### 9- Connector Pinout – Hybrid combined power and SFD3, SFD-M, and HDSL feedback

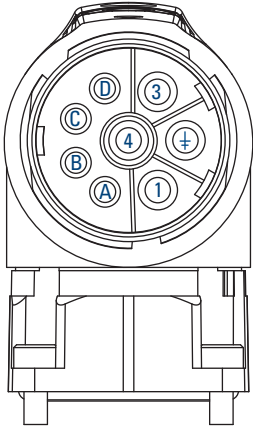

#### Power + SFD3/SFD-M/DSL

Pin	Function
1	U
⊕	PE
3	W
4	V
A	Brake +
B	Brake -
C	SFD - / DSL -
D	SFD + / DSL +

#### Power + SFD2

Pin	Function
1	U
⊕	PE
3	W
4	V
A	SFD +5 V
B	SFD +5 V RTN
C	SFD COM -
D	SFD COM +

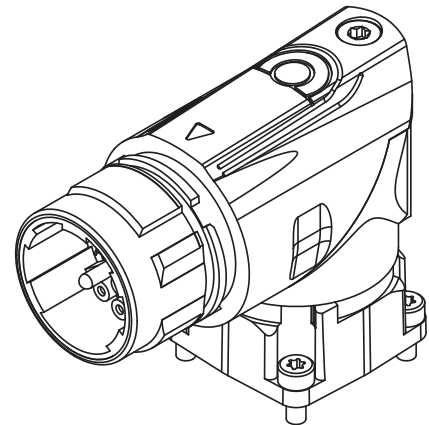

D- Connector

Power + SFD2 /SFD3 / DSL

Connector Part Number:  
BEDC-110-NN-00-00-1216-000

### itec®- 9- Connector Pinout – AKM1 only

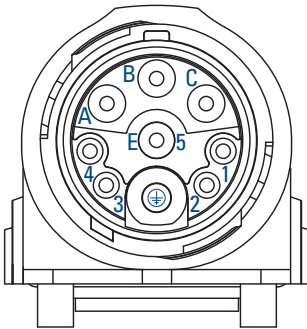

Power + SFD3

#### Power + SFD3

Pin	Function
1	Brake +
2	Brake -
3	SFD -
4	SFD +
5/E	N/C
A	Phase U
B	Phase W
C	Phase V
⊕	PE

#### Power + SFD2

Pin	Function
1	SFD +5 V
2	SFD +5 V RTN
3	SFD COM -
4	SFD COM+
5/E	N/C
A	Phase U
B	Phase W
C	Phase V
⊕	PE

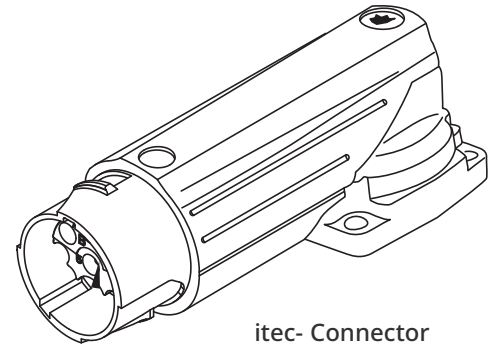

itec- Connector

Connector Part Number:  
EEDA-201-NN-00-00-0800-000

### E- Connector Pinout – AKM7-8 only

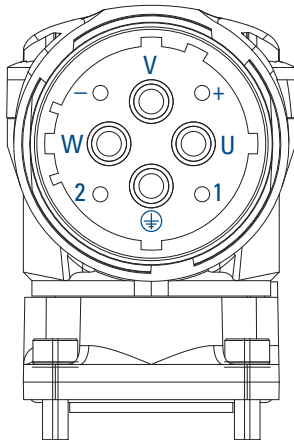

#### Power + SFD3

Pin	Function
U	U
⊕	PE
W	W
V	V
+	Brake +
-	Brake -
1	SFD-
2	SFD+

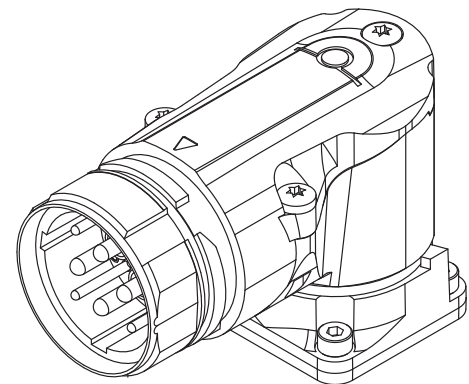

E- Connector

Note: The connector part numbers given are only valid for the "00" and "01" customization/seal option variants. For mating connector selection, please work with TE Connectivity to select the proper option based on your cable design (cable diameter and conductor size). Pinout still valid for AKM Washdown "0W" and AKM Food Grade "0F" Stainless Steel Hummel connector variants.

# AKM® Servo Motor Connector Pinouts

## Dual Molex Cable Options – Power & Feedback

### “M” Power and Feedback Connector Options

(AKM 1, 2, 3 & 4 Only) If additional dimensions or connectors are required, contact Kollmorgen Customer Support.

#### “M” Power Connector Options

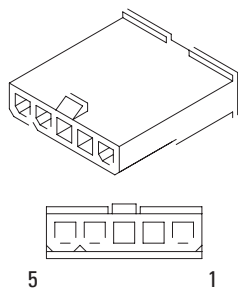

##### Power Connector – No Brake

Pin	Function	Color
1	U	Blue
2	V	Brown
3	W	Violet
4	Gnd	Grn/Yel
5	Shield	

Shield Connected to Motor  
Ground Internal to Motor

##### Power Connector – Brake

Pin	Function	Color
1	U	Blue
2	V	Brown
3	W	Violet
4	Gnd	Grn/Yel
5	Shield	
6	Brake+	Black
7	Brake-	Black
8	N/C	

Shield Connected to Motor  
Ground Internal to Motor

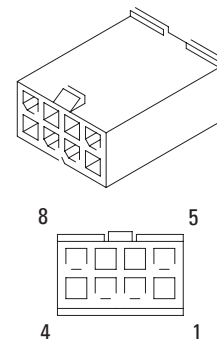

#### “M” Feedback Connector Options

##### SFD

Pin	Function	Color
1	SFD +5V	Red
2	SFD +5V RTN	Black
3	SFD COM-	Yellow
4	SFD COM+	Blue
5	SFD COM Shield	
6	N/C	
7	N/C	
8	N/C	
9	N/C	
10	N/C	

Shield is Not Connected at Motor End

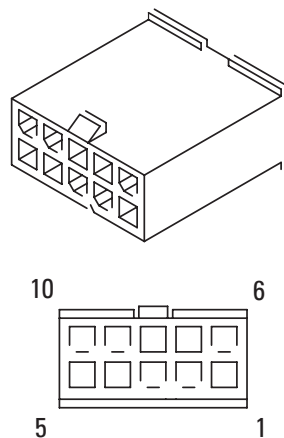

##### Resolver

Pin	Function	Color
1	N/C	
2	Thermal Sensor +	Orange
3	S4, COS-	Blue
4	S3, SIN-	Black
5	R2, REF-	Blk/Wht
6	Thermal Sensor -	Orange/White
7	S2, COS+	Yellow
8	S1, SIN+	Red
9	R1, REF+	Red/Wht
10	Shield	

Shield is Not Connected at Motor End

##### Commutating Encoder

Pin	Function	Color
1	B	Green
2	B	Grn/Blk
3	A	Blue
4	A	Blue/Blk
5	Z	Violet
6	Z	Violet/Blk
7	Gnd	Black
8	Thermal Sensor +	Orange
9	Thermal Sensor -	Orange/White
10	Vcc	Red
11	N/C	
12	N/C	
13	N/C	
14	N/C	
15	U	Brown
16	V	Grey
17	W	White
18	Shield	

Shield is Not Connected at Motor End

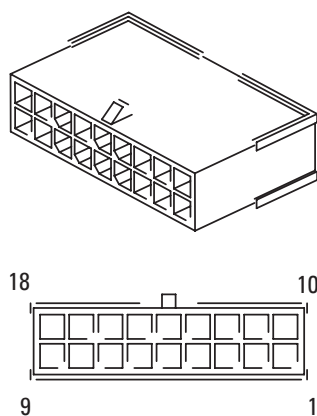

##### Absolute Encoder

Pin	“AA” & “AB”	DA, DB & LA, LB	Color
1	B-	B-	Red/Blk
2	Gnd	Gnd	Wht/Grn
3	A-	A-	Yel/Blk
4	Vcc (5Vdc)	Vcc (5Vdc)	Brn/Grn
5	Data	Data	Gray
6	N/C	N/C	
7	Thermal Sensor+	Thermal Sensor+	Green
8	Clock	Clock	Violet
9	B+	B+	Blu/Blk
10	Un Sense (Common)	Un Sense (Common)	White
11	A+	A+	Grn/Blk
12	Up Sense (VCC)	Up Sense (VCC)	Blue
13	Data	Data	Pink
14	Thermal Sensor-	Thermal Sensor-	Brown
15	Clock	Clock	Yellow
16	N/C	N/C	
17	N/C	N/C	
18	N/C	Shield	

Shield is Not Connected at Motor End

# Hybrid Molex Cable Options – Power & Feedback

## “P” Power + SFD Connector Option

(AKM 1, 2, 3 & 4 Only - Not available for Brake Motors)

### Power + SFD

Pin	Function	Color
1	SFD +5V	Red
2	SFD +5V RTN	Black
3	Power Shield	
4	Ground	Grn/Yel
5	U	Blue
6	SFD COM-	Yellow
7	SFD COM+	Blue
8	SFD COM Shield	
9	V	Brown
10	W	Violet

Power Shield Connected to Motor Ground Internal to Motor

Feedback Shield is Not Connected at Motor End

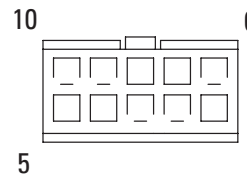
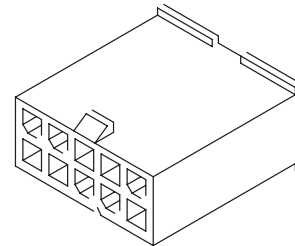

## Molex® Connector-Cable Lookup Table

(AKM 1, 2, 3 & 4 Only)



## Molex® Cable Mating Connectors

Cable Function	Connector Option Code	Motor Cable Connector	Motor Cable Composition	Mating Connector
Power	M	Molex 39-01-4056 (Eng No. 5559-05P3)	5-Pin Power Connector - No Brake	Molex 39-01-4050
		Molex 39-01-3083 (Eng No. 5559-08P1)	8-pin Power Connector with Brake	Molex 39-01-2080
Molex 43020-1001		8-Pin SFD	Molex 43025-1000	
Molex 43020-1001		8-Pin Resolver	Molex 43025-1000	
Feedback		Molex 43020-1801	18-Pin Commutating Encoder	Molex 43025-1800
		Molex 43020-1801	18-Pin Absolute Encoder DA, DB, LA, LB	Molex 43025-1800
		Molex 43020-1801	18-Pin Absolute Encoder AA, AB	Molex 43025-1800
	Molex 43020-1801	18-Pin Absolute Encoder AA, AB	Molex 43025-1800	
Power + SFD	P	Molex 39-01-3103 (Eng No. 5559-10P1)	10-Pin Power + SFD - No Brake	Molex 39-01-2100

# AKM Technical Guide

## I. L10 Bearing Fatigue

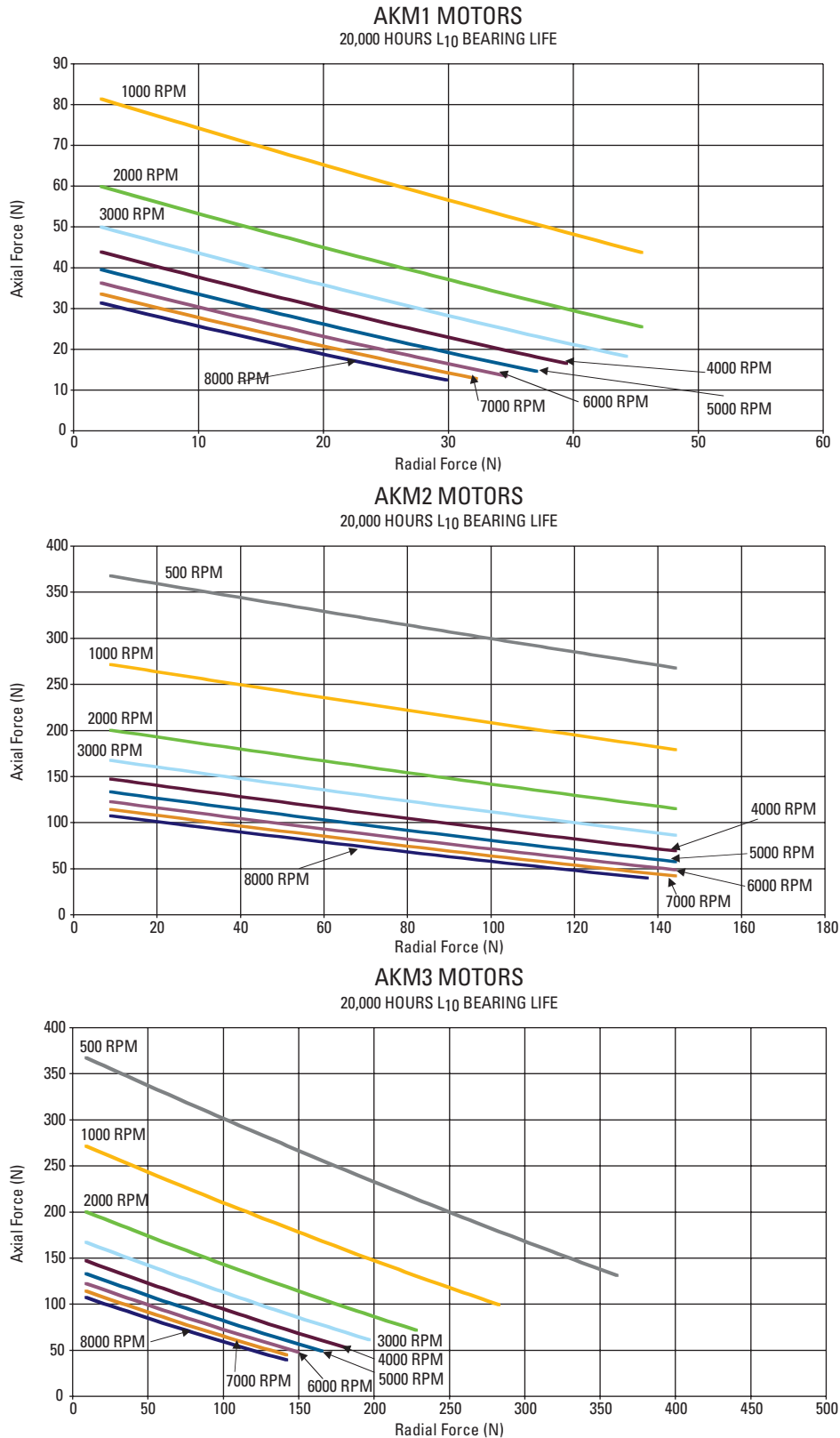

**AKM4 MOTORS**  
20,000 HOURS L<sub>10</sub> BEARING LIFE

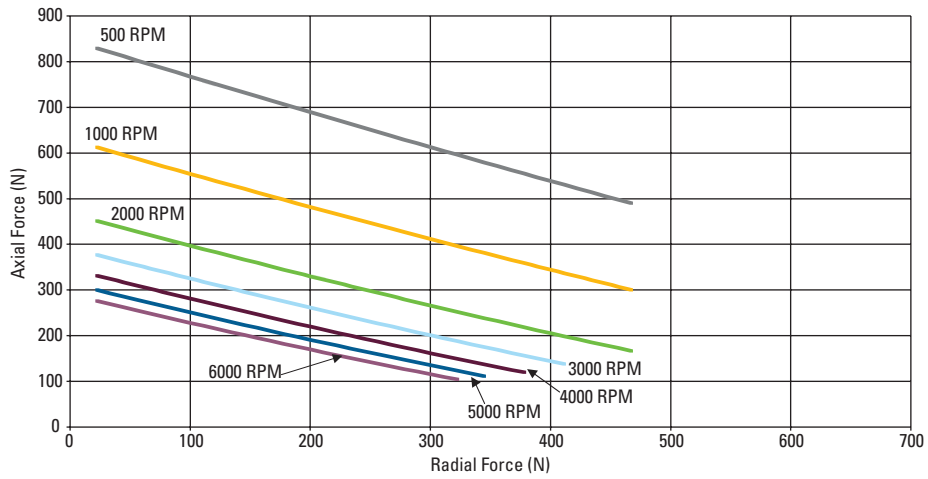

**AKM5 MOTORS**  
20,000 HOURS L<sub>10</sub> BEARING LIFE

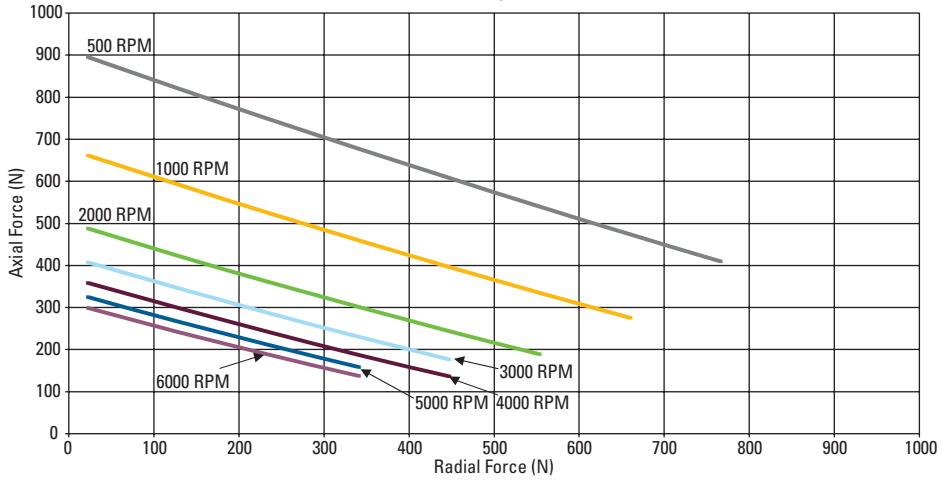

**AKM6 MOTORS**  
20,000 HOURS L<sub>10</sub> BEARING LIFE

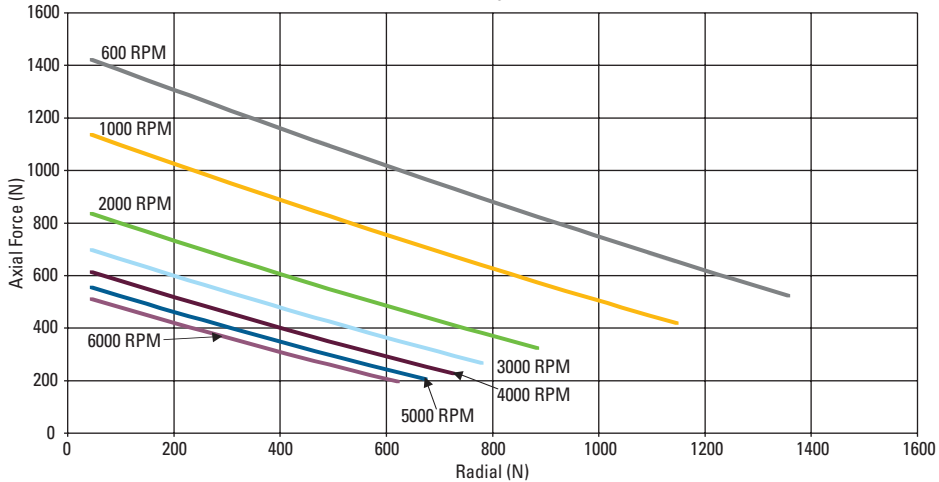

## I. L10 Bearing Fatigue (Continued)

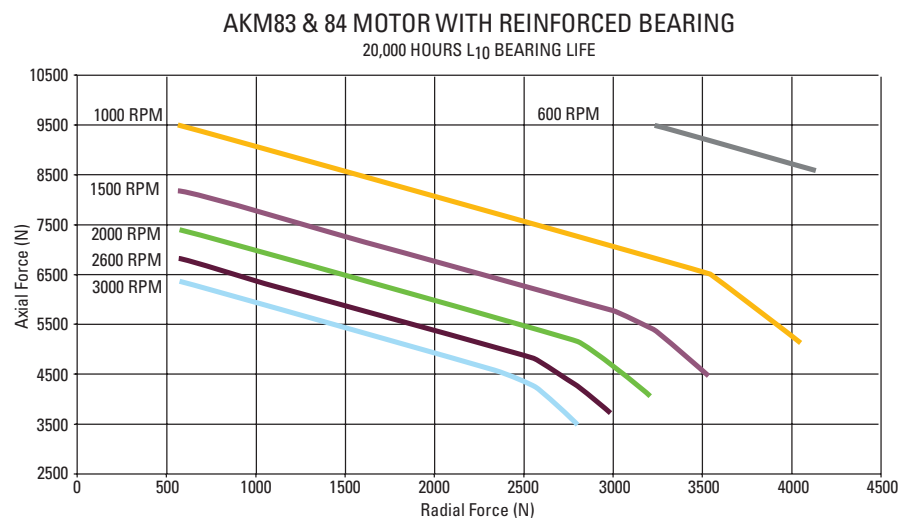
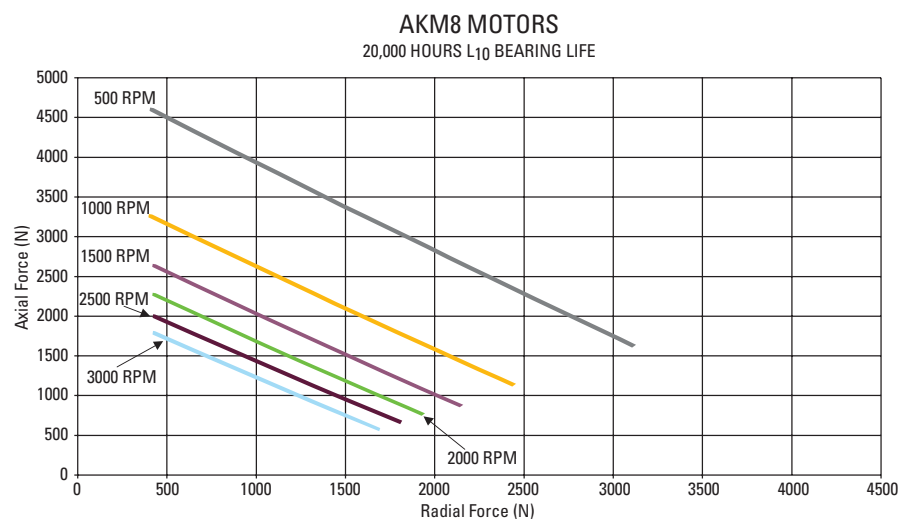
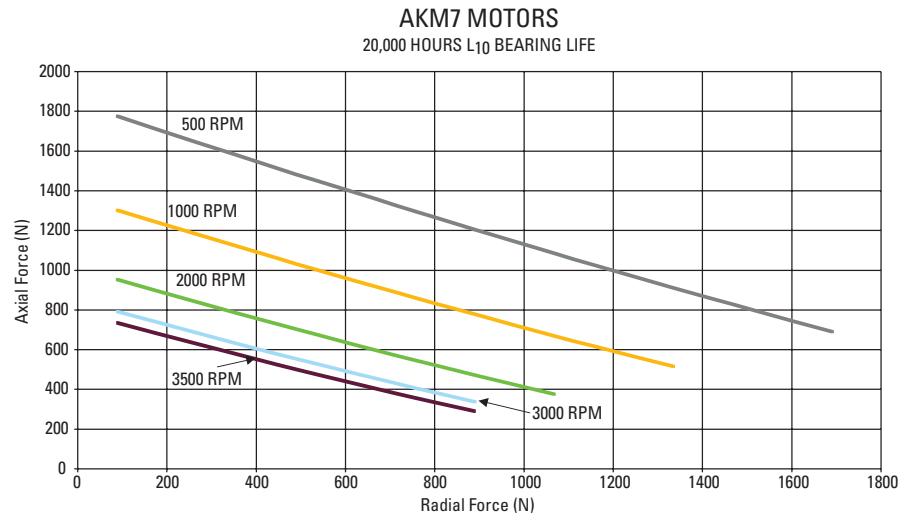

## II. Shaft Loading

Motor	Max. Radial Force (N)	Max. Axial Force (N)
AKM1	48	200
AKM2	150	600
AKM3	340	600
AKM4	500	1400
AKM5	830	1740
AKM6	1940	2200
AKM7	2300	3000
AKM8	2752	4750

The maximum radial load ratings reflect the following assumptions:

1. Motors are operated with peak torque of the longest member of the frame size.
2. Fully reversed load applied to the end of the smallest diameter standard mounting shaft extension. Excluding AKM4X-EK which is rated at 240 N max. radial force.
3. Infinite life with 99% reliability.
4. Safety factor = 2.

## III. Teflon Shaft Seals

There is a normal break-in period for our Teflon® shaft seals. Best conditions during the break-in period would be at the operational temperature and speed that would be typical for the application.

During the break-in period, some “shedding” of Teflon material is normal. The debris is not a sign of seal deterioration or failure. The material “shed” should be reduced with usage.

Typically, a few hours at operational speed is enough to break-in the shaft seal.

## IV. Thermal Sensor Protective Devices

The standard version of each motor is fitted with an electrically isolated PTC Avalanche-Type thermal sensor or PT1000 RTD Linear thermal sensor, depending on connector (see the Connector Options table). The thermal sensors do not provide any protection against short, heavy overloading.

The motor can be delivered with a PT1000 or KTY84/130 equivalent sensor optionally for certain connectors (see Thermal Sensor options 1 and 2). Please consult Kollmorgen Customer Support for optional thermal device requests based on motor configuration.

With digital feedback systems SFD (C), SFD3 (CA), SFD-M (CB) and Hiperface DSL (GE/GF), the temperature sensor status is transmitted digitally and evaluated in the drive.

Provided that our configured feedback cables are used, the sensor is integrated into the monitoring system of the digital servo amplifiers.

### Thermal Device Options: Resistance vs. Temperature Graphs

Kollmorgen AKD drives can directly interpret information from the motor thermal sensors to properly reflect the motor winding temperature. For other drives please refer to the graph Delta Between Motor Winding and Thermal Device on the following page.

#### Standard

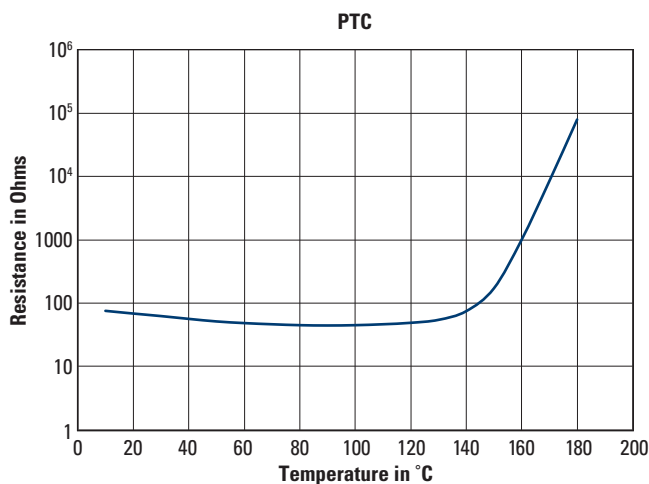

#### Option 1

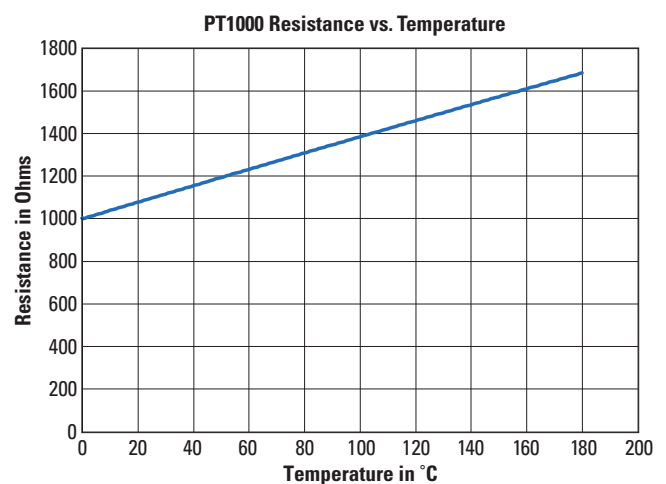

#### Option 2

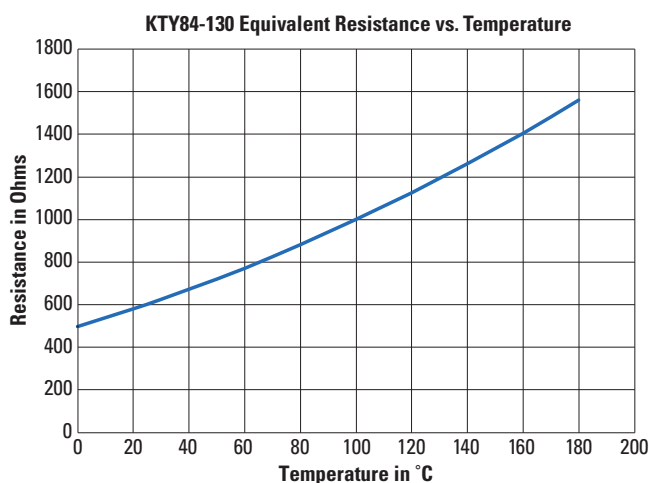

Note 1: PTC thermistor (155°C ± 5°C switching temperature) installed.

Resistance at 25°C: ≤550 ohms.

Switching Resistance: ≥1330 ohms within ±5°C of switch temperature.

Note 2: Optional KTY84-130 Nominal Resistance at 25°C, 603 ohms.

# AKM Technical Guide

## V. Delta Between Motor Winding and Thermal Device

When using a drive other than the Kollmorgen AKD you will need to account for the difference (Delta) in temperature between the value reported by the thermal sensor and the actual motor winding temperature. This is necessary to insure proper operation and protection of the motor.

The provided graph shows the delta between the reported device temperature on the x axis and the motor winding temperature on the y axis and should be used to adjust the response of the system for the difference between the thermal sensors reported temperature and the actual motor winding temperature.

### Examples:

At 60°C on thermal device temperature the winding temperature will be 1.8°C higher (61.8°C).

At 130°C on thermal device temperature the winding temperature will be 8.1°C higher (138.1°C).

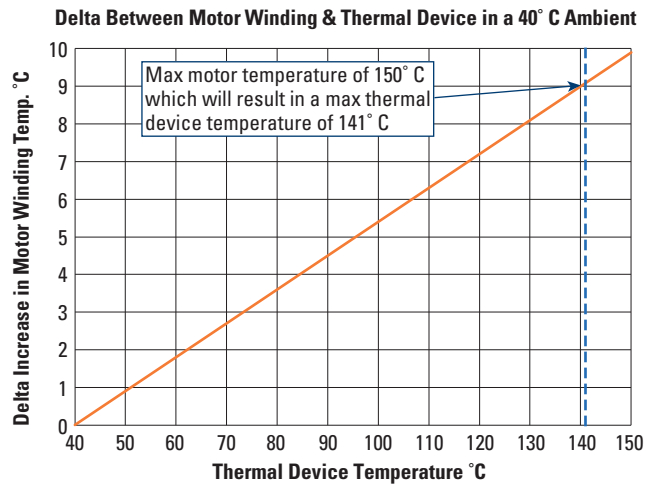

## VI. Motor Phasing Diagram

When the motor is rotated clockwise (CW) as viewed from front shaft end, the following BEMF voltage waveforms result:

- » Voltage phase-UV leads Voltage phase-VW by 120-degrees
- » Voltage phase-VW leads Voltage phase-WU by 120-degrees
- » Voltage phase-WU leads Voltage phase-UV by 120-degrees

### BEMF Waveforms

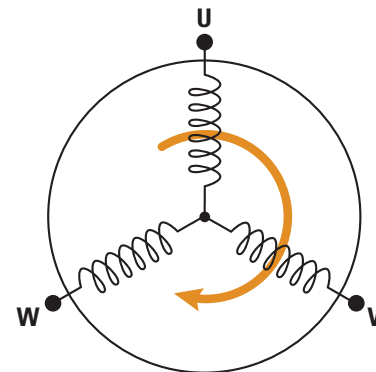
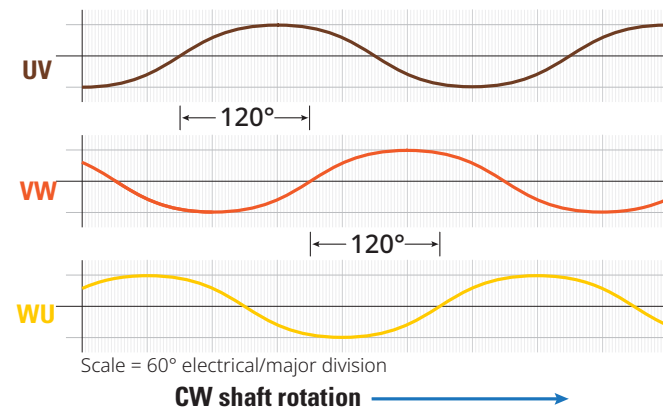

# Complete Motion and Automation Solutions

The highest performance and the right fit for any application.



## Online Design Tools

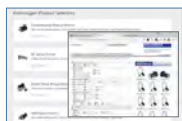

**Product Selector**  
Quickly choose the ideal products for your application needs.



**Motioneering®**  
Size your motion system based on application requirements and motion profiles.

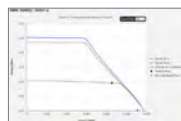

**Performance Curve Generator**  
Optimize housed and frameless motor windings based on power and environmental factors.



**3D Models**  
Visualize products in 3D and download CAD files for use in your design.



**Stepper Optimizer**  
Interactively choose the most efficient stepper solution for your application.



**AKD2G Safe Dynamic Brake Calculator**  
Specify and size the right braking components while saving development time.



Learn more and try our design tools now.

## More Expertise for a More Successful Machine

Our global engineering, service and support network provides deep knowledge of all the major industries that rely on advanced motion control and automation technology. We offer world-class engineering expertise, self-service design tools, personalized field service, and easy access to our design, application and manufacturing centers in strategic locations across the globe.

## About Kollmorgen

Kollmorgen, a Regal Rexnord brand, has more than 100 years of motion experience, proven in the industry's highest-performing, most reliable motors, drives, linear actuators, AGV (Automated Guided Vehicle) control solutions, and automation control platforms. We deliver breakthrough solutions that combine exceptional performance, reliability and ease of use, giving machine builders an irrefutable marketplace advantage.

Australian Distributor for Kollmorgen



**MOTION WERKZ**

hello@motion-werkz.com

www.motion-werkz.com

Call us: 0499 885 772

**KOLLMORGEN**

REGAL REXN RD BRAND

[www.kollmorgen.com](http://www.kollmorgen.com)

Specifications are subject to change without notice. It is the responsibility of the product user to determine the suitability of this product for a specific application. All trademarks are the property of their respective owners

© 2025 Kollmorgen Corporation. All rights reserved

KM\_SG\_000077\_RevF\_EN