

EKM Series Servo Motors

Selection Guide

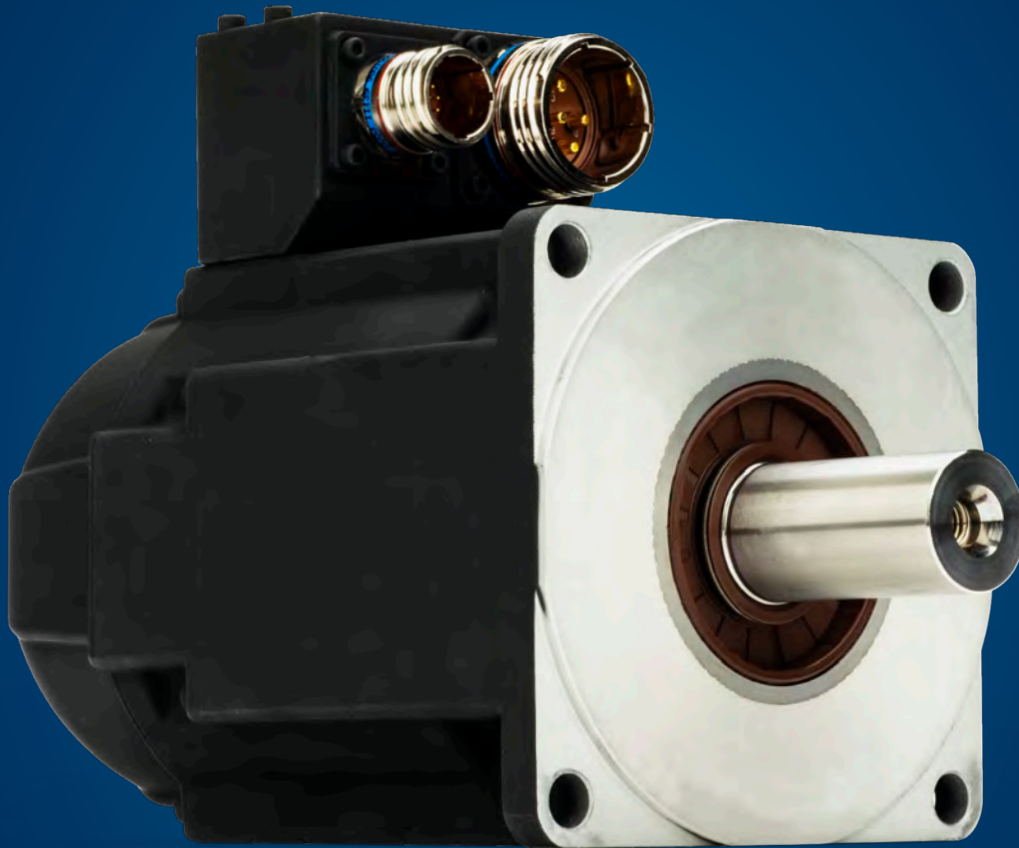

For Aerospace & Defense Applications

Australian Distributor for Kollmorgen



hello@motion-werkz.com
www.motion-werkz.com
Call us: 0499 885 772

KOLLMORGEN

A REGAL REXNORD BRAND

Kollmorgen – Serving the Aerospace and Defense Industry

The Kollmorgen team provides aerospace and defense customers with high standards of quality, innovation and technology to improve a machine's performance and reliability. In addition, Altra Motion's global manufacturing footprint, rapid customization and prototyping capabilities drive quick lead times which empowers Kollmorgen's customers to commission their machines faster.

Kollmorgen also offers the aerospace and defense industry unparalleled depth and breadth of motion control product solutions through a worldwide service and support infrastructure made up of field service engineers and support teams that are available when and where customers need them.



Removing the Barriers of Design, Sourcing, and Time

At Kollmorgen, we know that OEM engineers can achieve a lot more when obstacles aren't in the way. So, we clear obstacles in three important ways:

Integrating Standard and Custom Products

The optimal solution is often not clear-cut. Our application expertise allows us to modify standard products or develop totally custom solutions across our whole product portfolio so that designs can take flight.

Providing Motion Solutions, Not Just Components

As companies reduce their supplier base and focus their engineering manpower on the product design, they need a total system supplier with a wide range of integrated solutions. Kollmorgen offers complete solutions as well as motion subsystems that combine programming software, engineering services and best-in-class motion components.

Global Footprint

With direct sales, engineering support, manufacturing facilities, and distributors spanning the Americas, Europe, the Middle East, and Asia, we're close to OEMs worldwide. Our proximity helps speed delivery and lend support where and when they're needed.

Financial and Operational Stability

Kollmorgen is part of Regal Rexnord. A key driver in the growth of all Regal Rexnord segments is the Regal Rexnord Business System, which relies on the principle of "kaizen" – or continuous improvement. Using world-class tools, cross-disciplinary teams of exceptional people evaluate processes and develop plans that result in superior performance.

Kollmorgen: Your partner. In Motion.

Trademarks

AKD is a registered trademark of Kollmorgen Corporation
 AKM is a registered trademark of Kollmorgen Corporation
 Cartridge DDR is a registered trademark of Kollmorgen Corporation
 EnDat is a registered trademark of Dr. Johannes Heidenhain GmbH
 EtherCAT is a registered trademark and patented technology, licensed by Beckhoff Automation GmbH
 Ethernet/IP is a registered trademark of ODVA, Inc.
 Ethernet/IP Communication Stack copyright (c) 2009, Rockwell Automation
 sercos@ is a registered trademark of sercos@ international e.V.
 HIPERFACE and HIPERFACE DSL are registered trademarks of Max Stegmann GmbH
 PROFINET is a registered trademark of PROFINET and PROFINET International (PI)
 SIMATIC is a registered trademark of SIEMENS AG
 SpeedTec, ytec, itec and htec are registered trademarks of TE Connectivity Ltd.
 Windows is a registered trademark of Microsoft Corporation

Table of Contents

- ▶ **EKM Series Servo Motor Introduction** 4
- ▶ **EKM Series Servo Motor Quick Guide** 6
- ▶ **EKM Series Servo Motor Nomenclature** 9
- ▶ **EKM Performance and Dimension Data** 10
 - EKM2x 10
 - EKM3x 12
 - EKM4x 14
 - EKM5x 16
 - EKM6x 18
 - EKM7x 20
- ▶ **L₁₀ Bearing Fatigue Life and Shaft Fatigue Rating** 22
- ▶ **EKM Motor Resolver Feedback Details** 24
- ▶ **Failsafe, Holding Brake** 24
- ▶ **EKM Motor Connector Pinouts** 25
- ▶ **Kollmorgen Solutions** 27
 - Automation and Motion Control 27
 - Self-help Tools 27

EKM Servo Motor Introduction

Enhanced, High-Performance, Brushless AC Servo motors

EKM Series Motors are Mil-Spec 810E rated and IP67 sealed for duty in harsh environmental conditions.

- » Industry leading power and torque density
- » Meets IP67 sealing requirements and is 100% leak-tested housing for further moisture blocking
- » Ideal for most military specifications
- » C.O.T.S (commercial off the shelf) solution
- » Standard product offering with customization available



Features

Torque

Offers 0.43 to 53 N-m continuous stall torque (3.8 to 467 lb in).

Speed

Speeds up to 8000 rpm meet high speed application requirements while the windings can be specifically tailored to lower speeds as well.

Voltage

EKM Series Motors feature 480 Vac High Voltage Insulation.

Feedback

Rugged Resolver feedback can survive the most extreme environments.

Friction Torque

Low-cog, low harmonic distortion magnetic designs.

Connectivity

High performance nickel-plated MIL-C-38999 connectors with total environmental sealing, quick mating, triple lead threaded, self-locking coupling, as well as EMI and RFI shielding. In addition, both front-facing and rear-facing options are available.

Thermal

EKM Series Motors are rated for operation over a temperature range of -51°C to 54°C and feature 155°C (class F) insulation materials which include a thermistor.

Corrosion

Stainless steel shaft and fasteners prevent external corrosion while a chemical agent resistant paint allows resistance to harsh outdoor environments and chemicals.

Sealing

IP67 rated for ingress prevention and brief submergence as well as 100-psi wash down. In addition, a viton shaft seal comes standard.

Shock

Tested per MIL-STD-810E, Method 516.4, Procedure 1, 75g half sine wave pulses for 11 ms, 3 times in each axis (total of 18 shocks).

Vibration

Tested per MIL-STD-810E, Method 514.4, Procedure 1, Operational 0.01g²/Hz 5-30Hz, 0.02g²/Hz 75-500Hz, 0.006g²/Hz 900-2000 Hz.

Mounting

International Standard Mount available.

Additional motion control solutions are available with these options:

- » Fail-safe brakes
- » Shaft variations
- » Custom windings

Advanced Motor Design Features

The enhanced EKM motor series is Mil-Spec 810E rated, IP67 sealed, and comes standard with a stainless steel shaft and chemical-agent-resistant paint.

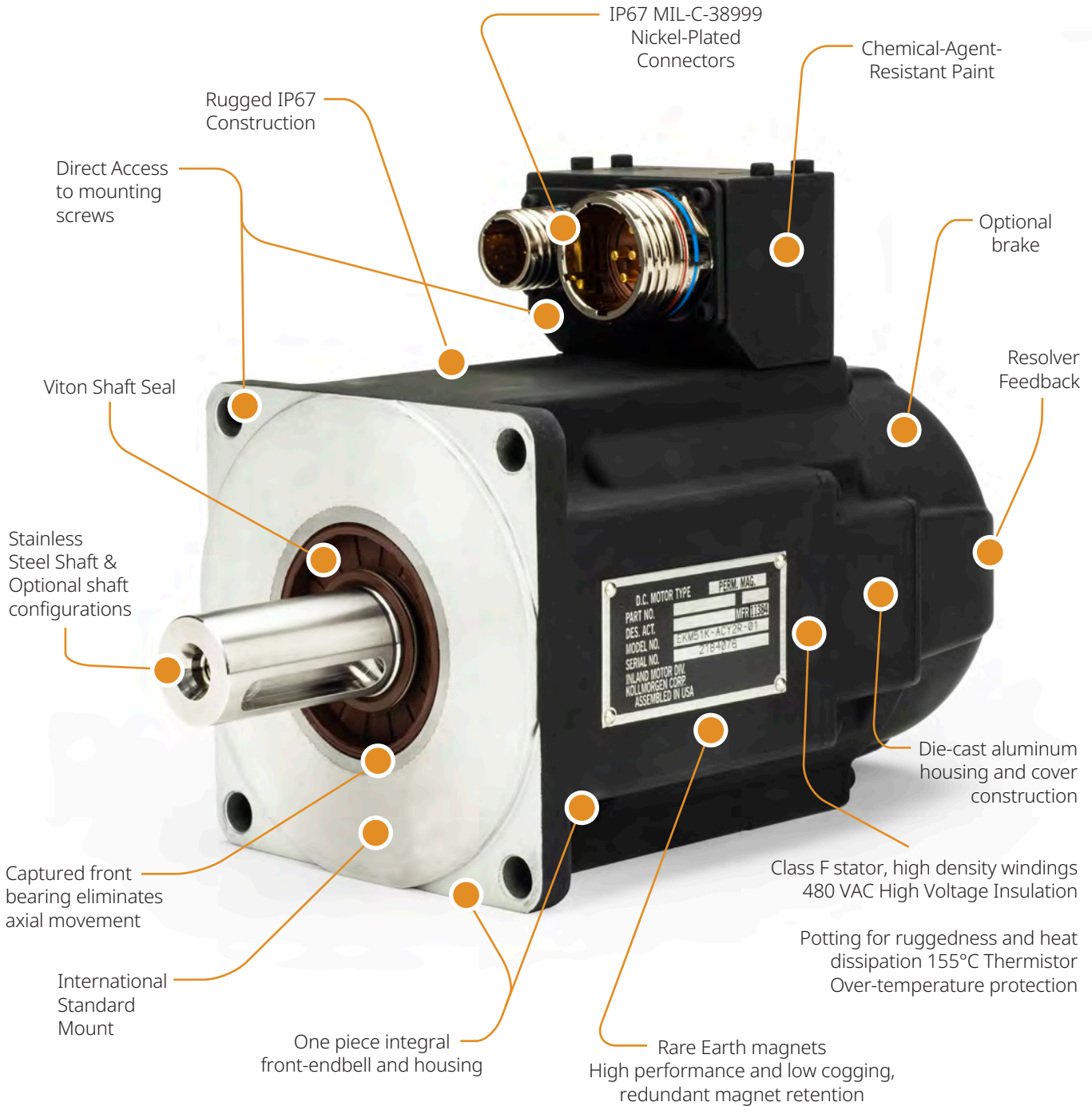

Note: The EKM Series is not CE compliant.

EKM Servo Motor Quick Guide

Motor Performance, 240 Vac (320 Vdc bus) assuming Sinusoidal Commutation ^①

Motor Model	Peak Stall Torque T _{ps} ^② N-m (lb-in)	Peak Torque at Max. Speed T _{ms} N-m (lb-in)	Cont. Stall Torque T _{cs} N-m (lb-in)	Cont. Rated Torque T _{cr} N-m (lb-in)	Speed at Knee ω _k rpm	Rated Speed ω _r rpm	Max. Speed ω _{max} rpm	Cont. Stall Current I _{cs} Arms	Current at Peak Torque I _{ps} Arms
EKM21C	1.42 (12.6)	0.70 (6.22)	0.43 (3.57)	0.34 (3.02)	4,210	8,000	8,000	1.58	6.30
EKM22C	2.68 (23.7)	0.0 (0.0)	0.79 (7.02)	0.73 (6.49)	1,810	3,500	5,620	1.39	5.60
EKM22E	2.71 (24.0)	1.56 (13.8)	0.82 (7.28)	0.65 (5.77)	5,160	8,000	8,000	2.73	10.9
EKM23C	3.72 (32.9)	0.0 (0.0)	1.08 (9.58)	1.03 (9.12)	1,330	2,500	4,250	1.41	5.60
EKM23D	3.79 (33.5)	0.0 (0.0)	1.11 (9.84)	0.98 (8.69)	2,950	5,000	6,520	2.19	8.80
EKM23F	3.83 (33.9)	3.23 (28.6)	1.13 (10.0)	0.89 (7.89)	6,910	8,000	8,000	4.31	17.2
EKM24C	4.68 (41.4)	0.0 (0.0)	1.33 (11.8)	1.27 (11.27)	1,170	2,000	3,530	1.42	5.70
EKM24D	4.71 (41.7)	0.0 (0.0)	1.36 (12.0)	1.24 (11.0)	2,520	4,000	5,410	2.21	8.80
EKM24F	4.77 (42.2)	2.37 (21.0)	1.37 (12.1)	1.07 (9.49)	5,420	8,000	8,000	3.89	15.6
EKM31C	3.83 (33.9)	0.0 (0.0)	1.10 (9.76)	1.07 (9.47)	1,220	2,500	4,040	1.37	5.50
EKM31E	3.95 (34.9)	0.72 (6.39)	1.15 (10.2)	0.90 (7.98)	3,970	6,000	8,000	2.99	12.0
EKM32C	6.87 (60.8)	0.0 (0.0)	1.95 (17.3)	1.90 (16.8)	623	1,500	2,460	1.44	5.70
EKM32D	7.00 (61.9)	0.0 (0.0)	1.99 (17.6)	1.88 (16.7)	1,580	2,500	3,750	2.23	8.90
EKM32H	7.21 (63.8)	2.82 (25.0)	2.05 (18.2)	1.40 (12.4)	5,210	7,000	8,000	5.50	22.0
EKM33C	9.71 (85.9)	0.0 (0.0)	2.66 (23.6)	2.59 (22.9)	291	1,000	1,840	1.47	5.90
EKM33E	9.91 (87.6)	0.0 (0.0)	2.74 (24.3)	2.57 (22.8)	1,360	2,000	3,130	2.58	10.3
EKM33H	10.2 (89.8)	0.0 (0.0)	2.83 (25.0)	2.22 (19.7)	3,960	5,500	6,630	5.62	22.5
EKM41C	6.05 (53.6)	0.0 (0.0)	1.88 (16.6)	1.83 (16.2)	604	1,200	2,550	1.46	5.80
EKM41E	6.21 (54.9)	0.0 (0.0)	1.95 (17.2)	1.75 (15.5)	1,680	3,000	4,810	2.85	11.4
EKM41H	6.29 (55.6)	3.73 (33.0)	1.99 (17.6)	1.55 (13.7)	3,640	6,000	6,000	5.60	22.4
EKM42E	11.2 (99.3)	0.0 (0.0)	3.35 (29.6)	3.05 (27.0)	1,000	1,800	2,730	2.74	11.0
EKM42G	11.4 (101)	0.0 (0.0)	3.46 (30.6)	2.83 (25.0)	2,050	3,500	4,650	4.80	19.2
EKM42J	11.5 (102)	6.45 (57.0)	3.49 (30.8)	2.31 (20.4)	3,790	6,000	6,000	8.40	33.7
EKM43E	15.8 (140)	0.0 (0.0)	4.63 (40.9)	4.17 (36.9)	724	1,500	1,995	2.76	11.0
EKM43G	16.0 (142)	0.0 (0.0)	4.73 (41.8)	3.93 (34.7)	1,600	2,500	3,460	4.87	19.5
EKM43K	16.2 (143)	5.37 (47.5)	4.83 (42.7)	2.55 (22.5)	3,410	6,000	6,000	9.60	38.3
EKM44E	19.8 (175)	0.0 (0.0)	5.69 (50.3)	5.13 (45.3)	655	1,200	1,677	2.85	11.4
EKM44G	20.1 (178)	0.0 (0.0)	5.81 (51.4)	4.83 (42.7)	1,400	2,000	2,885	5.00	20.0
EKM44J	20.3 (180)	0.0 (0.0)	5.93 (52.4)	3.77 (33.3)	2,680	4,000	5,005	8.80	35.2
EKM51E	11.5 (101)	0.0 (0.0)	4.57 (40.4)	4.28 (37.8)	917	1,200	2,000	2.75	28.3
EKM51G	11.6 (102)	0.0 (0.0)	4.62 (40.8)	3.90 (34.5)	1,900	2,500	3,470	4.84	14.5
EKM51K	11.9 (105)	4.30 (38.0)	4.77 (42.2)	2.22 (19.6)	3,830	5,500	6,000	9.40	28.3
EKM52G	21.4 (189)	0.0 (0.0)	8.30 (73.4)	7.56 (66.8)	1,090	1,500	1,915	4.72	14.2
EKM52K	21.8 (193)	0.0 (0.0)	8.47 (74.9)	6.67 (59.0)	2,360	3,000	3,685	9.30	27.8
EKM52M	21.8 (193)	0.0 (0.0)	8.47 (74.9)	5.07 (44.8)	3,440	4,500	5,220	13.1	39.4
EKM53G	29.6 (262)	0.0 (0.0)	11.3 (99.7)	10.6 (93.5)	841	1,000	1,440	4.77	14.3
EKM53K	30.0 (265)	0.0 (0.0)	11.5 (101)	9.97 (88.1)	1,870	2,000	2,780	9.40	28.1
EKM53M	29.7 (263)	0.0 (0.0)	11.3 (99.7)	8.59 (76.1)	2,860	3,000	4,050	13.4	40.3
EKM53P	29.7 (263)	0.0 (0.0)	11.3 (99.7)	5.75 (50.9)	4,200	5,000	5,770	19.1	57.4
EKM54K	38.3 (338)	0.0 (0.0)	14.3 (126)	12.6 (111)	1,570	1,800	2,290	9.70	29.2
EKM54L	37.4 (330)	0.0 (0.0)	14.0 (123)	11.4 (101)	2,200	2,500	3,040	12.5	37.5
EKM54N	37.5 (331)	0.0 (0.0)	14.0 (123)	9.72 (85.9)	3,170	3,500	4,320	17.8	53.4
EKM62K	29.9 (264)	0.0 (0.0)	12.0 (105)	10.2 (89.7)	1,470	2,000	2,700	9.60	28.7
EKM62M	30.0 (265)	0.0 (0.0)	12.0 (105)	9.25 (81.8)	2,100	3,000	3,770	13.4	40.3
EKM62P	30.2 (267)	0.0 (0.0)	12.1 (106)	7.85 (69.4)	3,040	4,500	5,250	18.8	56.5
EKM63K	42.2 (374)	0.0 (0.0)	16.6 (146)	14.7 (129)	1,200	1,500	2,020	9.90	29.7
EKM63M	42.8 (378)	0.0 (0.0)	16.8 (148)	14.1 (124)	1,700	2,000	2,770	13.8	41.4
EKM63N	42.8 (378)	0.0 (0.0)	16.8 (148)	12.8 (113)	2,180	3,000	3,500	17.4	52.2
EKM64K	53.3 (471)	0.0 (0.0)	20.6 (182)	19.0 (168)	932	1,200	1,510	9.20	27.5
EKM64L	53.9 (476)	0.0 (0.0)	20.8 (183)	18.2 (160)	1,340	1,500	2,080	12.8	38.4
EKM64P	52.7 (465)	0.0 (0.0)	20.2 (178)	15.8 (139)	2,100	2,500	3,120	18.6	55.9
EKM65K	64.3 (568)	0.0 (0.0)	24.6 (217)	22.6 (199)	859	1,000	1,350	9.80	29.4
EKM65M	65.0 (574)	0.0 (0.0)	24.8 (219)	21.7 (191)	1,230	1,500	1,860	13.6	40.9
EKM65N	63.5 (561)	0.0 (0.0)	24.1 (213)	19.6 (173)	1,720	2,000	2,500	17.8	53.3
EKM72P	78.3 (692)	0.0 (0.0)	29.2 (258)	23.6 (208)	1,300	1,800	2,170	18.7	56.1
EKM73P	111 (979)	0.0 (0.0)	41.4 (365)	34.5 (305)	1,010	1,300	1,610	19.5	58.6

① See detailed motor specifications beginning on page 10.

② Peak torque ratings are for 5 seconds.

Motor Performance, 400 Vac (560 Vdc bus) assuming Sinusoidal Commutation ^①

Motor Model	Peak Stall Torque T _{ps} ^② N-m (lb-in)	Peak Torque at Max. Speed T _{ms} N-m (lb-in)	Cont. Stall Torque T _{cs} N-m (lb-in)	Cont. Rated Torque T _{cr} N-m (lb-in)	Speed at Knee ω _k rpm	Rated Speed ω _r rpm	Max. Speed ω _{max} rpm	Cont. Stall Current I _{cs} Arms	Current at Peak Torque I _{ps} Arms
EKM22C	2.68 (23.7)	1.25 (11.1)	0.79 (7.01)	0.63 (5.60)	4,560	8,000	8,000	1.39	5.60
EKM23C	3.72 (32.9)	0.0 (0.0)	1.08 (9.57)	0.94 (8.34)	3,610	5,500	7,450	1.41	5.60
EKM23D	3.79 (33.5)	2.82 (25.0)	1.11 (9.84)	0.87 (7.72)	6,240	8,000	8,000	2.19	8.80
EKM24C	4.68 (41.4)	0.0 (0.0)	1.33 (11.8)	1.20 (10.6)	3,160	4,500	6,190	1.42	5.70
EKM24D	4.71 (41.6)	2.43 (21.5)	1.36 (12.1)	1.06 (9.40)	5,430	8,000	8,000	2.21	8.80
EKM31C	3.83 (33.9)	0.0 (0.0)	1.10 (9.75)	0.95 (8.42)	3,220	5,000	7,090	1.37	5.50
EKM32C	6.87 (60.8)	0.0 (0.0)	1.95 (17.3)	1.81 (16.0)	2,050	3,000	4,310	1.44	5.70
EKM32D	7.00 (61.9)	0.0 (0.0)	1.99 (17.6)	1.60 (14.2)	3,610	5,500	6,560	2.23	8.90
EKM33C	9.71 (85.9)	0.0 (0.0)	2.66 (23.5)	2.49 (22.0)	1,460	2,000	3,230	1.47	5.90
EKM33E	9.91 (87.6)	0.0 (0.0)	2.74 (24.3)	2.29 (20.3)	3,170	4,500	5,490	2.58	10.3
EKM41C	6.05 (53.5)	0.0 (0.0)	1.88 (16.6)	1.70 (15.0)	1,580	3,000	4,480	1.46	5.80
EKM41E	6.21 (54.9)	3.22 (28.5)	1.95 (17.2)	1.51 (13.3)	3,330	6,000	6,000	2.85	11.4
EKM42C	11.0 (97.5)	0.0 (0.0)	3.28 (29.0)	3.03 (26.8)	910	1,500	2,510	1.40	5.61
EKM42E	11.2 (99.3)	0.0 (0.0)	3.35 (29.6)	2.74 (24.2)	2,130	3,500	4,790	2.74	11.0
EKM42G	11.4 (101)	6.64 (58.7)	3.46 (30.6)	2.28 (20.2)	3,890	6,000	6,000	4.80	19.2
EKM43E	15.8 (140)	0 (0)	4.63 (40.9)	3.85 (34.0)	1,640	2,500	3,490	2.76	11.0
EKM43G	16.0 (142)	1.18 (10.4)	4.73 (41.8)	2.94 (26.0)	3,100	5,000	6,000	4.87	19.5
EKM44E	19.8 (175)	0.0 (0.0)	5.69 (50.3)	4.73 (41.8)	1,470	2,000	2,945	2.85	11.4
EKM44G	20.1 (178)	0.0 (0.0)	5.81 (51.4)	3.69 (32.6)	2,730	4,000	5,050	5.00	20.0
EKM44J	20.3 (180)	15.9 (141)	5.93 (52.4)	2.68 (23.7)	4,960	6,000	6,000	8.80	35.2
EKM51E	11.5 (101)	0.0 (0.0)	4.57 (40.4)	3.85 (34.0)	1,920	2,500	3,490	2.75	8.24
EKM51G	11.6 (102)	1.13 (9.99)	4.62 (40.8)	2.49 (22.0)	3,580	5,000	6,000	4.84	14.5
EKM52E	21.2 (187)	0.0 (0.0)	8.21 (72.6)	7.48 (66.1)	1,280	1,500	2,150	3.00	9.00
EKM52G	21.4 (189)	0.0 (0.0)	8.30 (73.4)	6.93 (61.3)	2,130	2,500	3,350	4.72	14.2
EKM52K	21.8 (192)	8.39 (74.2)	8.47 (74.9)	3.77 (33.3)	4,330	5,500	6,000	9.30	27.8
EKM53G	29.6 (261)	0.0 (0.0)	11.3 (99.6)	9.72 (85.9)	1,680	2,000	2,515	4.77	14.3
EKM53K	30.0 (265)	0.0 (0.0)	11.5 (101)	7.52 (66.5)	3,470	4,000	4,855	9.40	28.1
EKM54G	37.7 (333)	0.0 (0.0)	14.2 (125)	12.8 (113)	1,420	1,500	2,085	5.00	14.9
EKM54K	38.3 (338)	0.0 (0.0)	14.3 (126)	9.97 (88.1)	2,940	3,500	4,015	9.70	29.2
EKM54L	37.4 (330)	0.0 (0.0)	14.0 (124)	8.00 (70.7)	4,030	4,500	5,315	12.5	37.5
EKM62G	29.6 (261)	0.0 (0.0)	11.7 (103)	10.2 (89.7)	1,330	1,800	2,430	4.85	14.6
EKM62K	29.9 (263)	0.0 (0.0)	12.0 (106)	8.76 (77.4)	2,710	3,500	4,705	9.60	28.7
EKM62M	30.0 (264)	11.2 (98.6)	12.0 (106)	5.49 (48.5)	3,810	6,000	6,000	13.4	40.3
EKM63G	41.6 (367)	0.0 (0.0)	16.3 (144)	14.8 (130)	941	1,200	1,625	4.48	13.4
EKM63K	42.4 (374)	0.0 (0.0)	16.6 (146)	12.7 (112)	2,230	3,000	3,520	9.90	29.7
EKM63M	42.8 (378)	0.0 (0.0)	16.8 (148)	11.1 (97.7)	3,100	4,000	4,840	13.8	41.4
EKM63N	42.8 (378)	7.50 (66.3)	16.8 (148)	9.35 (82.7)	3,940	5,000	6,000	17.4	52.2
EKM64K	53.3 (471)	0.0 (0.0)	20.6 (182)	17.0 (150)	1,760	2,000	2,645	9.20	27.5
EKM64L	53.9 (476)	0.0 (0.0)	20.8 (183)	15.4 (136)	2,470	3,000	3,635	12.8	38.4
EKM64P	52.7 (465)	0.0 (0.0)	20.2 (178)	11.7 (103)	3,810	4,500	5,455	18.6	55.9
EKM65K	64.3 (568)	0.0 (0.0)	24.6 (217)	20.0 (176)	1,630	2,000	2,365	9.80	29.4
EKM65M	65.0 (574)	0.0 (0.0)	24.8 (219)	19.0 (168)	2,280	2,500	3,245	13.6	40.9
EKM65N	63.5 (561)	0.0 (0.0)	24.1 (213)	15.8 (139)	3,150	3,500	4,365	17.8	53.3
EKM72K	79.0 (698)	0.0 (0.0)	29.5 (260)	25.0 (220)	1,100	1,500	1,855	9.30	27.8
EKM72M	79.5 (702)	0.0 (0.0)	29.8 (263)	23.4 (206)	1,560	2,000	2,585	13.0	38.9
EKM72P	78.3 (691)	0.0 (0.0)	29.2 (258)	19.9 (175)	2,350	3,000	3,795	18.7	56.1
EKM73M	113 (997)	0.0 (0.0)	41.8 (369)	33.6 (297)	1,230	1,500	1,935	13.6	40.8
EKM73P	111 (979)	0.0 (0.0)	41.4 (366)	28.3 (250)	1,830	2,400	2,825	19.5	58.6
EKM74L	143 (1262)	0.0 (0.0)	52.8 (466)	45.3 (400)	941	1,200	1,455	12.9	38.7
EKM74P	142 (1253)	0.0 (0.0)	52.3 (462)	37.4 (330)	1,420	1,800	2,115	18.5	55.5

① See detailed motor specifications beginning on page 10.

② Peak torque ratings are for 5 seconds.

EKM Servo Motor Quick Guide

Motor Performance, 480 Vac (640 Vdc bus) assuming Sinusoidal Commutation ^①

Motor Model	Peak Stall Torque T_{ps} ^② N-m (lb-in)	Peak Torque at Max. Speed T_{ms} N-m (lb-in)	Cont. Stall Torque T_{cs} N-m (lb-in)	Cont. Rated Torque T_{cr} N-m (lb-in)	Speed at Knee ω_k rpm	Rated Speed ω_r rpm	Max. Speed ω_{max} rpm	Cont. Stall Current I_{cs} Arms	Current at Peak Torque I_{ps} Arms
EKM22C	2.68 (23.7)	1.71 (15.1)	0.79 (7.01)	0.63 (5.60)	5,440	8,000	8,000	1.39	5.60
EKM23C	3.72 (32.9)	0.80 (7.1)	1.08 (9.57)	0.90 (7.98)	4,340	7,000	8,000	1.41	5.60
EKM23D	3.79 (33.5)	2.82 (25.0)	1.11 (9.84)	0.87 (7.72)	7,320	8,000	8,000	2.19	8.80
EKM24C	4.68 (41.4)	0.0 (0.0)	1.33 (11.8)	1.17 (10.4)	3,800	5,500	7,080	1.42	5.70
EKM24D	4.71 (41.7)	3.46 (30.6)	1.36 (12.0)	1.06 (9.4)	6,390	8,000	8,000	2.21	8.80
EKM31C	3.83 (33.9)	0.21 (1.88)	1.10 (9.75)	0.86 (7.63)	3,850	6,000	7,990	1.37	5.50
EKM32C	6.87 (60.8)	0.0 (0.0)	1.95 (17.3)	1.78 (15.8)	2,510	3,500	4,930	1.44	5.70
EKM32D	7.00 (61.9)	0.0 (0.0)	1.99 (17.6)	1.53 (13.6)	4,280	6,000	7,500	2.23	8.90
EKM33C	9.71 (85.9)	0.0 (0.0)	2.66 (23.5)	2.45 (21.7)	1,820	2,500	3,680	1.47	5.90
EKM33E	9.91 (87.6)	0.0 (0.0)	2.74 (24.2)	2.22 (19.7)	3,760	5,000	6,270	2.58	10.3
EKM41C	6.05 (53.5)	0.0 (0.0)	1.88 (16.6)	1.67 (14.8)	1,880	3,500	5,120	1.46	5.80
EKM41E	6.21 (54.9)	4.01 (35.4)	1.95 (17.2)	1.51 (13.3)	3,870	6,000	5,990	2.85	11.4
EKM42C	11.0 (97.5)	0.0 (0.0)	3.28 (29)	2.95 (26.1)	1,120	2,000	2,870	1.40	5.61
EKM42E	11.2 (99.3)	0.0 (0.0)	3.35 (29.6)	2.65 (23.4)	2,500	4,000	5,470	2.74	11.0
EKM42G	11.4 (101)	7.92 (70.0)	3.46 (30.6)	2.28 (20.1)	4,500	6,000	6,000	4.80	19.2
EKM43E	15.8 (140)	0.0 (0.0)	4.63 (40.9)	3.69 (32.6)	1,930	3,000	4,000	2.76	11.0
EKM43G	16.0 (142)	6.68 (59.0)	4.73 (41.8)	2.50 (22.1)	3,600	6,000	6,000	4.87	19.5
EKM44E	19.8 (175)	0.0 (0.0)	5.69 (50.3)	4.49 (39.7)	1,730	2,500	3,370	2.85	11.4
EKM44G	20.1 (178)	0.0 (0.0)	5.81 (51.4)	3.12 (27.6)	3,180	5,000	5,780	5.00	20.0
EKM44J	20.3 (180)	18 (159)	5.93 (52.4)	2.68 (23.7)	5,720	6,000	6,000	8.80	35.2
EKM51E	11.5 (101)	0.0 (0.0)	4.57 (40.4)	3.67 (32.4)	2,240	3,000	4,010	2.75	8.24
EKM51G	11.6 (102)	5.81 (51.4)	4.62 (40.8)	1.81 (16)	4,140	6,000	6,000	4.84	14.5
EKM52E	21.2 (187)	0.0 (0.0)	8.21 (72.6)	7.15 (63.2)	1,500	2,000	2,470	3.00	9.00
EKM52G	21.4 (189)	0.0 (0.0)	8.30 (73.4)	6.53 (57.7)	2,480	3,000	3,840	4.72	14.2
EKM52K	21.8 (192)	15.7 (139)	8.47 (74.9)	3.12 (27.6)	4,990	6,000	6,000	9.30	27.8
EKM53G	29.6 (261)	0.0 (0.0)	11.3 (100)	9.37 (82.8)	1,960	2,400	2,880	4.77	14.3
EKM53K	30 (265)	0.0 (0.0)	11.5 (101)	6.72 (59.4)	4,000	4,500	5,550	9.40	28.1
EKM54G	37.7 (333)	0.0 (0.0)	14.2 (125)	12.2 (108)	1,660	2,000	2,390	5.00	14.9
EKM54K	38.3 (338)	0.0 (0.0)	14.3 (126)	9.12 (80.6)	3,390	4,000	4,590	9.70	29.2
EKM62G	29.6 (261)	0.0 (0.0)	11.7 (103)	10.0 (88.0)	1,550	2,000	2,790	4.85	14.6
EKM62K	29.9 (264)	0.0 (0.0)	12.0 (106)	7.77 (68.7)	3,130	4,500	5,400	9.60	28.7
EKM62M	30.0 (265)	18.6 (164)	12.0 (106)	5.49 (48.5)	4,380	6,000	6,000	13.4	40.3
EKM63G	41.6 (367)	0.0 (0.0)	16.3 (144)	14.4 (127)	1,100	1,500	1,860	4.48	13.4
EKM63K	42.4 (374)	0.0 (0.0)	16.6 (146)	11.8 (104)	2,570	3,500	4,030	9.90	29.7
EKM63M	42.8 (378)	0.0 (0.0)	16.8 (148)	10.3 (90.6)	3,570	4,500	5,550	13.8	41.4
EKM63N	42.8 (378)	24.4 (215)	16.8 (148)	6.75 (59.7)	4,530	6,000	6,000	17.4	52.2
EKM64K	53.3 (471)	0.0 (0.0)	20.6 (182)	16.1 (142)	2,040	2,500	3,030	9.20	27.5
EKM64L	53.9 (476)	0.0 (0.0)	20.8 (183)	14.2 (125)	2,850	3,500	4,160	12.8	38.4
EKM64P	52.7 (465)	15.4 (136)	20.2 (178)	8.80 (78.0)	4,380	5,500	6,000	18.6	55.9
EKM65K	64.3 (568)	0.0 (0.0)	24.6 (217)	19.5 (172)	1,890	2,200	2,710	9.80	29.4
EKM65M	65.0 (574)	0.0 (0.0)	24.8 (219)	17.9 (158)	2,620	3,000	3,720	13.6	40.9
EKM65N	63.5 (561)	0.0 (0.0)	24.1 (213)	14.5 (128)	3,620	4,000	4,990	17.8	53.3
EKM72K	79.0 (698)	0.0 (0.0)	29.5 (260)	23.8 (210)	1,270	1,800	2,130	9.30	27.8
EKM72M	79.5 (702)	0.0 (0.0)	29.8 (263)	21.9 (193)	1,790	2,500	2,960	13.0	38.9
EKM72P	78.3 (692)	0.0 (0.0)	29.2 (258)	18.0 (159)	2,700	3,500	4,350	18.7	56.1
EKM73M	113 (997)	0.0 (0.0)	41.8 (369)	31.9 (282)	1,420	1,800	2,220	13.6	40.8
EKM73P	111 (979)	0.0 (0.0)	41.4 (366)	26.1 (230)	2,100	2,800	3,230	19.5	58.6
EKM74L	143 (1262)	0.0 (0.0)	52.8 (466)	41.3 (365)	1,090	1,400	1,670	12.9	38.7
EKM74P	142 (1253)	0.0 (0.0)	52.3 (462)	35.7 (315)	1,630	2,000	2,420	18.5	55.5

① See detailed motor specifications beginning on page 10.

② Peak torque ratings are for 5 seconds.

EKM Model Nomenclature

EKM Brushless Servo Motor

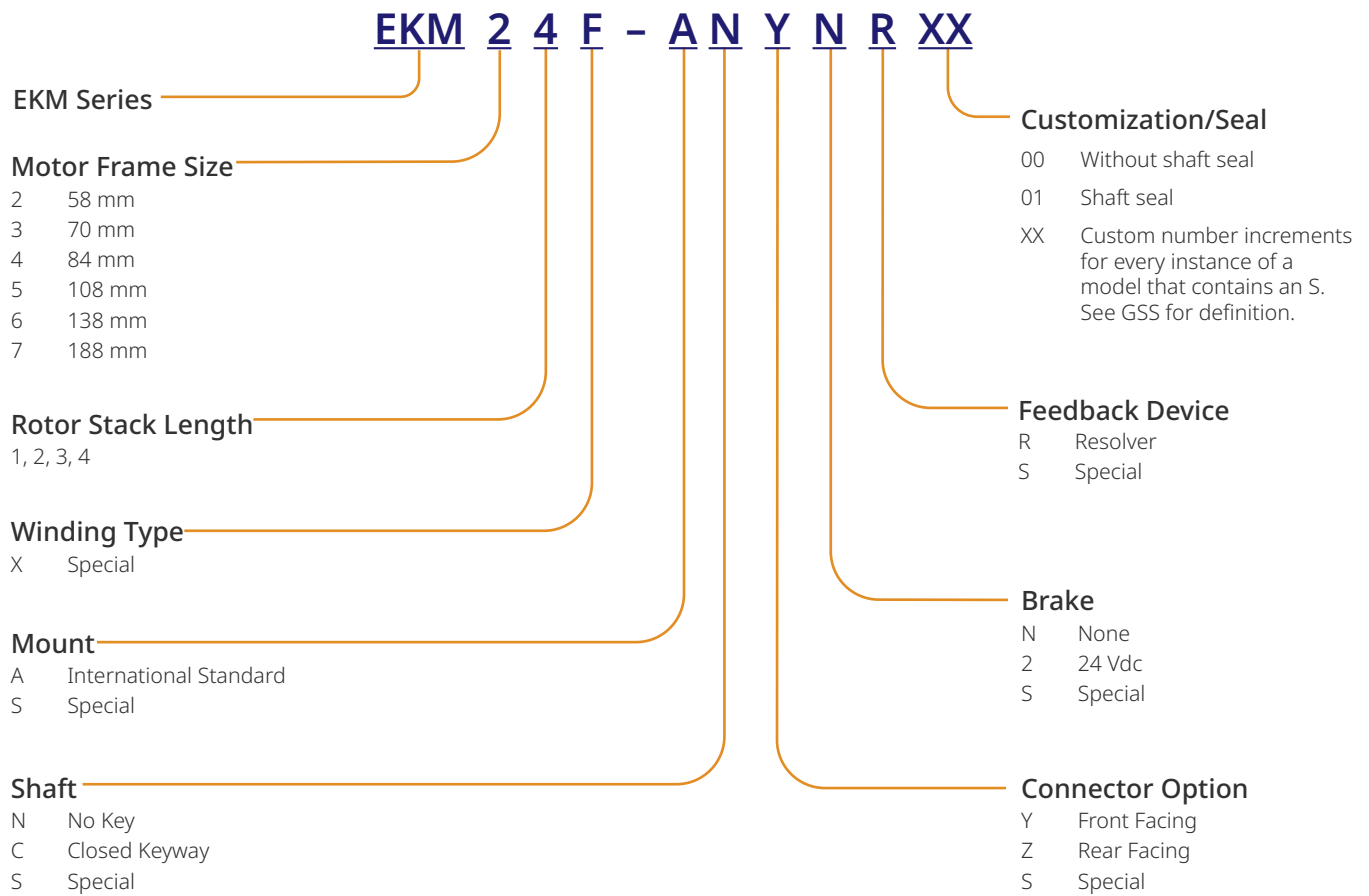

EKM Servo Motor Specifications

EKM2x Performance Data – Up to 480 Vac (640 Vdc bus) voltage

Performance & Parameters	Symbol	Units	EKM21			EKM22			EKM23			EKM24				
			Windings			Windings			Windings			Windings				
			C	E	G	C	E	G	C	D	F	C	D	F		
Max Rated Voltage	-	Vac	240	120	-	480	240	120	480	480	240	480	480	240		
		Vdc	320	160	75	640	320	160	640	640	320	640	640	320		
Continuous (Stall) Torque ⑤	Tcs	N-m	0.433	0.453	0.453	0.793	0.823	0.833	1.08	1.11	1.13	1.33	1.36	1.37		
		lb-in	3.83	4.01	4.01	7.02	7.29	7.38	9.59	9.86	10.03	11.8	12.1	12.2		
Continuous (Stall) Current	Ics	Arms	1.58	3.11	4.87	1.39	2.73	4.82	1.41	2.19	4.31	1.42	2.21	3.89		
		Adc	1.94	3.81	5.97	1.70	3.34	5.90	1.73	2.68	5.28	1.74	2.71	4.73		
Peak Torque	Tp	N-m	1.42	1.44	1.46	2.68	2.71	2.74	3.72	3.79	3.83	4.68	4.71	4.77		
		lb-in	12.6	12.7	12.9	23.7	24.0	24.3	32.9	33.6	33.9	41.4	41.7	42.2		
Peak Current	Ip	Arms	6.30	12.4	19.5	5.60	10.9	19.3	5.60	8.80	17.2	5.70	8.80	15.6		
		Adc	7.72	15.2	23.9	6.86	13.4	23.6	6.86	10.8	21.1	6.98	10.8	19.1		
Torque Constant at 140°C	Kt	N-m / Arms	0.30	0.16	0.10	0.61	0.32	0.18	0.80	0.52	0.27	0.97	0.63	0.36		
		lb-in / Arms	2.7	1.4	0.9	5.4	2.8	1.6	7.1	4.6	2.4	8.6	5.6	3.2		
BEMF Constant ②	Ke	Vrms / Krpm	19.5	10.2	6.6	39.0	20.4	11.7	51.8	33.8	17.6	62.4	40.8	23.4		
Resistance ②	Rm	Ohms	13.0	3.42	1.44	20.0	5.22	1.77	21.2	8.77	2.34	20.4	9.02	2.94		
Inductance ②	mH	mH	19	5.2	2.2	36	10	3.2	41	17	4.7	44	19	6.2		
75 VDC	Rated Speed ① ③	Nrtd	rpm	-	2000	4000	-	1000	2500	-	-	1500	-	-	1000	
		Rated Torque ① ③ ⑤	Trtd	N-m	-	0.433	0.413	-	0.803	0.783	-	-	1.10	-	-	1.34
				lb-in	-	3.83	3.66	-	7.11	6.93	-	-	9.77	-	-	11.9
Rated Power ① ③	Prtd	kW	-	0.091	0.17	-	0.084	0.20	-	-	0.17	-	-	0.14		
		Hp	-	0.12	0.23	-	0.11	0.27	-	-	0.23	-	-	0.19		
120 Vac (160 Vdc)	Rated Speed ① ③	Nrtd	rpm	2500	7000	-	1000	3500	7000	1000	1500	4500	-	1500	3000	
		Rated Torque ① ③ ⑤	Trtd	N-m	0.413	0.363	-	0.783	0.763	0.693	1.06	1.07	1.02	-	1.31	1.28
				lb-in	3.66	3.21	-	6.93	6.76	6.14	9.41	9.50	9.06	-	11.6	11.4
Rated Power ① ③	Prtd	kW	0.11	0.27	-	0.082	0.28	0.51	0.11	0.17	0.48	-	0.21	0.40		
		Hp	0.14	0.36	-	0.11	0.37	0.68	0.15	0.23	0.65	-	0.28	0.54		
240 Vac (320 Vdc)	Rated Speed ① ③	Nrtd	rpm	8000	-	-	3500	8000	-	2500	5000	8000	2000	4000	8000	
		Rated Torque ① ③ ⑤	Trtd	N-m	0.343	-	-	0.733	0.653	-	1.03	0.983	0.893	1.27	1.24	1.07
				lb-in	3.04	-	-	6.49	5.78	-	9.15	8.71	7.91	11.3	11.0	9.50
Rated Power ① ③	Prtd	kW	0.29	-	-	0.27	0.55	-	0.27	0.51	0.75	0.27	0.52	0.90		
		Hp	0.39	-	-	0.36	0.73	-	0.36	0.69	1.00	0.36	0.70	1.20		
400 Vac (560 Vdc)	Rated Speed ① ③	Nrtd	rpm	-	-	-	8000	-	-	5500	8000	-	4500	8000	-	
		Rated Torque ① ③ ⑤	Trtd	N-m	-	-	-	0.633	-	-	0.943	0.873	-	1.20	1.06	-
				lb-in	-	-	-	5.61	-	-	8.35	7.73	-	10.7	9.41	-
Rated Power ① ③	Prtd	kW	-	-	-	0.53	-	-	0.54	0.73	-	0.57	0.89	-		
		Hp	-	-	-	0.71	-	-	0.73	0.98	-	0.76	1.19	-		
480 Vac (640 Vdc)	Rated Speed ① ③	Nrtd	rpm	-	-	-	8000	-	-	7000	8000	-	5500	8000	-	
		Rated Torque ① ③ ⑤	Trtd	N-m	-	-	-	0.633	-	-	0.903	0.873	-	1.17	1.06	-
				lb-in	-	-	-	5.61	-	-	8.00	7.73	-	10.39	9.41	-
Rated Power ① ③	Prtd	kW	-	-	-	0.53	-	-	0.66	0.73	-	0.68	0.89	-		
		Hp	-	-	-	0.71	-	-	0.89	0.98	-	0.91	1.19	-		
Inertia (includes resolver)	Jm	kg-cm ²	0.11			0.16			0.22			0.27				
		lb-in-s ²	9.50E-05			1.40E-04			1.90E-04			2.40E-04				
Brake Inertia (additional)	Jm	kg-cm ²	0.012			0.012			0.012			0.012				
		lb-in-s ²	1.10E-05			1.10E-05			1.10E-05			1.10E-05				
Static Friction (includes shaft seal)	Tf	N-m	0.049			0.052			0.054			0.057				
		lb-in	0.434			0.461			0.478			0.505				
Viscous Damping	Kdv	N-m / krpm	0.0046			0.0055			0.0065			0.0074				
		lb-in / krpm	0.04			0.05			0.06			0.07				
Weight ⑥	W	kg	0.91			1.18			1.45			1.77				
		lb	2.00			2.60			3.20			3.90				
Thermal Time Constant	TCT	minutes	8			9			10			11				
Thermal Resistance	Rth	°C / Watt	1.43			1.19			1.10			1.07				
Heat Sink Size	Aluminum	inch	10" x 10" x 1/4"			10" x 10" x 1/4"			10" x 10" x 1/4"			10" x 10" x 1/4"				
Poles Pair			3			3			3			3				
Maximum Mechanical Speed ④	Nmax	rpm	8,000			8,000			8,000			8,000				

Notes:

① Motor Performance based on $\Delta T = 100^\circ\text{C}$ in a 40°C ambient (winding temp = 140°C) with listed Heat Sink.

② Motor Parameters BEMF, Resistance, and Inductance measured at 25°C .

③ All data referenced to sinusoidal commutation.

④ Speed may be limited by Vbus.

⑤ Brake option reduces continuous torque by: EKM21 = 0.0 Nm, EKM22 = 0.01 Nm, EKM23 = 0.02 Nm, EKM24 = 0.05 Nm

⑥ Motor weight does not include brake option. EKM2 brake adds 0.27 kg (0.59 lb).

EKM2x Frame Dimensional Drawings

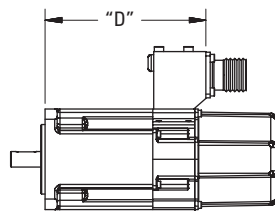
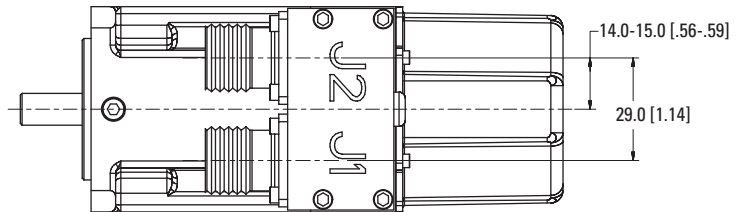
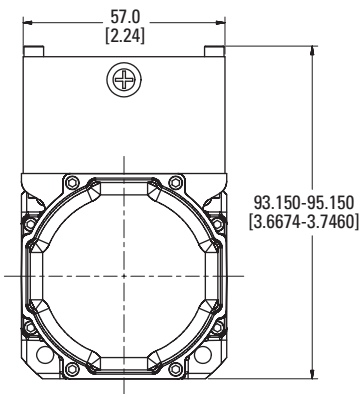
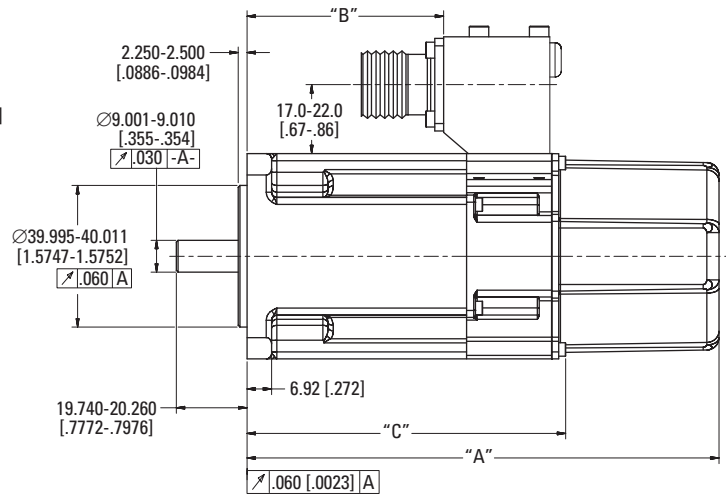
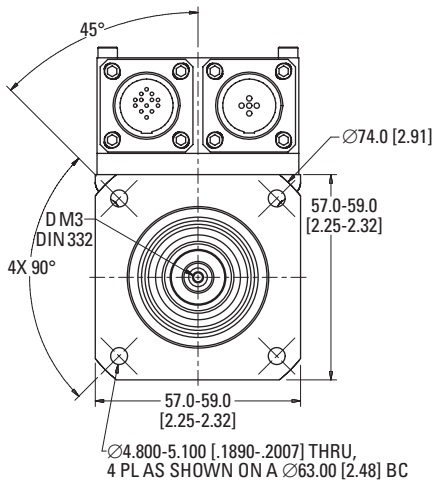

REAR CONNECTOR MOUNTING OPTION

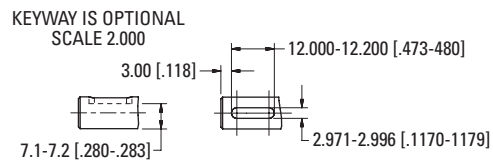

KEYWAY IS OPTIONAL
SCALE 2.000

Model	"A"	"B"	"C"	"D"
EKM21	132.35 - 134.35	54.0 - 57.0	89.05 - 91.05	91.0 - 94.0
EKM22	151.35 - 153.35	73.0 - 75.0	108.05 - 110.05	110.0 - 113.0
EKM23	170.35 - 172.35	92.0 - 95.0	127.05 - 129.05	129.0 - 132.0
EKM24	189.35 - 191.35	111.0 - 114.0	146.05 - 148.05	148.0 - 151.0

Dimensions are in mm [inches].
Product designed in metric.
English conversions provided for reference only.

*Complete EKM series model nomenclature can be found on page 9.

EKM Servo Motor Specifications

EKM3x Performance Data – Up to 480 Vac (640 Vdc bus) voltage

Performance & Parameters	Symbol	Units	EKM31			EKM32			EKM33				
			Windings			Windings			Windings				
			C	E	H	C	D	H	C	E	H		
Max Rated Voltage	-	Vac	480	240	120	480	480	240	480	480	240		
		Vdc	640	320	160	640	640	320	640	640	320		
Continuous (Stall) Torque ⑤	T _{cs}	N-m	1.10	1.15	1.18	1.95	1.99	2.05	2.66	2.74	2.83		
		lb-in	9.8	10.2	10.5	17.3	17.7	18.2	23.6	24.3	25.1		
Continuous (Stall) Current	I _{cs}	Arms	1.37	2.99	5.85	1.44	2.23	5.50	1.47	2.58	5.62		
		Adc	1.68	3.66	7.17	1.76	2.73	6.74	1.80	3.16	6.88		
Peak Torque	T _p	N-m	3.83	3.95	4.01	6.87	7.00	7.21	9.71	9.91	10.2		
		lb-in	33.9	35.0	35.5	60.8	62.0	63.9	86.0	87.8	90.3		
Peak Current	I _p	Arms	5.50	12.0	23.4	5.70	8.90	22.0	5.90	10.3	22.5		
		Adc	6.74	14.7	28.7	6.98	10.9	27.0	7.23	12.6	27.6		
Torque Constant at 140°C	K _t	N-m / Arms	0.85	0.41	0.21	1.40	0.92	0.39	1.86	1.10	0.52		
		lb-in / Arms	7.5	3.6	1.9	12.4	8.1	3.5	16.5	9.7	4.6		
BEMF Constant ②	K _e	V _{rms} / Krpm	54.5	26.1	13.7	89.8	59.0	24.8	120	70.6	33.4		
Resistance ②	R _m	Ohms	21.4	4.74	1.29	23.8	10.30	1.69	26.6	9.01	1.96		
Inductance ②	mH	mH	38	8.6	2.4	47	20	3.6	54	19	4.1		
75 VDC	Rated Speed ① ③	Nrtd	-	750	2000	-	-	1200	-	-	800		
		Rated Torque ① ③ ⑤	T _{rtd}	N-m	-	1.14	1.15	-	-	2.01	-	-	2.77
				lb-in	-	10.1	10.2	-	-	17.8	-	-	24.6
Rated Power ① ③	P _{rtd}	kW	-	0.090	0.24	-	-	0.25	-	-	0.23		
		Hp	-	0.12	0.32	-	-	0.34	-	-	0.31		
120 Vac (160 Vdc)	Rated Speed ① ③	Nrtd	-	2500	6000	-	1000	3000	-	-	2500		
		Rated Torque ① ③ ⑤	T _{rtd}	N-m	-	1.12	0.923	-	1.95	1.91	-	-	2.61
				lb-in	-	9.95	8.17	-	17.3	16.9	-	-	23.1
Rated Power ① ③	P _{rtd}	kW	-	0.29	0.58	-	0.20	0.60	-	-	0.68		
		Hp	-	0.39	0.78	-	0.27	0.81	-	-	0.92		
240 Vac (320 Vdc)	Rated Speed ① ③	Nrtd	2500	6000	-	1500	2500	7000	1000	2000	5500		
		Rated Torque ① ③ ⑤	T _{rtd}	N-m	1.07	0.903	-	1.90	1.88	1.40	2.59	2.57	2.22
				lb-in	9.50	8.00	-	16.9	16.7	12.4	23.0	22.8	19.7
Rated Power ① ③	P _{rtd}	kW	0.28	0.57	-	0.30	0.49	1.03	0.27	0.54	1.28		
		Hp	0.38	0.76	-	0.40	0.66	1.38	0.36	0.72	1.72		
400 Vac (560 Vdc)	Rated Speed ① ③	Nrtd	5000	-	-	3000	5500	-	2000	4500	-		
		Rated Torque ① ③ ⑤	T _{rtd}	N-m	0.953	-	-	1.81	1.60	-	2.49	2.29	-
				lb-in	8.44	-	-	16.1	14.2	-	22.1	20.3	-
Rated Power ① ③	P _{rtd}	kW	0.50	-	-	0.57	0.92	-	0.52	1.08	-		
		Hp	0.67	-	-	0.76	1.24	-	0.70	1.45	-		
480 Vac (640 Vdc)	Rated Speed ① ③	Nrtd	6000	-	-	3500	6000	-	2500	5000	-		
		Rated Torque ① ③ ⑤	T _{rtd}	N-m	0.863	-	-	1.78	1.53	-	2.45	2.22	-
				lb-in	7.64	-	-	15.8	13.6	-	21.7	19.7	-
Rated Power ① ③	P _{rtd}	kW	0.54	-	-	0.65	0.96	-	0.64	1.16	-		
		Hp	0.73	-	-	0.88	1.29	-	0.86	1.56	-		
Inertia (includes resolver)	J _m	kg-cm ²	0.33			0.59			0.85				
		lb-in-s ²	2.90E-04			5.20E-04			7.50E-04				
Brake Inertia (additional)	J _m	kg-cm ²	0.012			0.012			0.012				
		lb-in-s ²	1.10E-05			1.10E-05			1.10E-05				
Static Friction (includes shaft seal)	T _f	N-m	0.061			0.067			0.073				
		lb-in	0.540			0.593			0.646				
Viscous Damping	K _{dv}	N-m / krpm	0.002			0.003			0.004				
		lb-in / krpm	0.02			0.03			0.04				
Weight ⑥	W	kg	1.64			2.32			3.00				
		lb	3.60			5.10			6.60				
Thermal Time Constant	TCT	minutes	14			17			20				
Thermal Resistance	R _{th}	°C / Watt	1.11			0.92			0.78				
Heat Sink Size	Aluminum	inch	10" x 10" x 1/4"			10" x 10" x 1/4"			10" x 10" x 1/4"				
Poles Pair			4			4			4				
Maximum Mechanical Speed ④	N _{max}	rpm	8,000			8,000			8,000				

Notes:

① Motor Performance based on ΔT = 100°C in a 40°C ambient (winding temp = 140°C) with listed Heat Sink.

② Motor Parameters BEMF, Resistance, and Inductance measured at 25°C.

③ All data referenced to sinusoidal commutation.

④ Speed may be limited by V_{bus}.

⑤ Brake option reduces continuous torque by: EKM31 = 0.0 Nm, EKM32 = 0.05 Nm, EKM33 = 0.1 Nm,

⑥ Motor weight does not include brake option. EKM3 brake adds 0.35 kg (0.77 lb.).

EKM3x Frame Dimensional Drawings

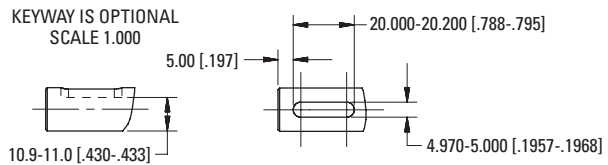
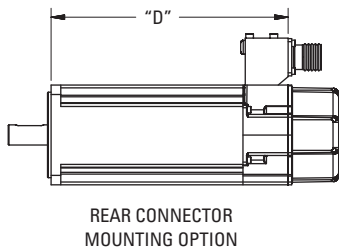
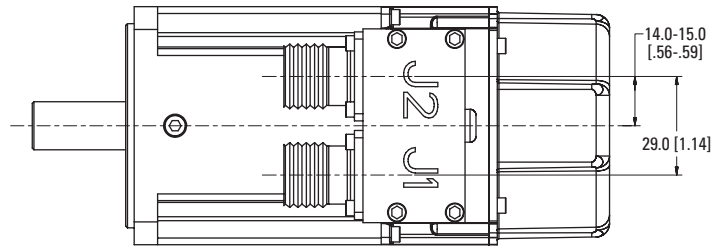
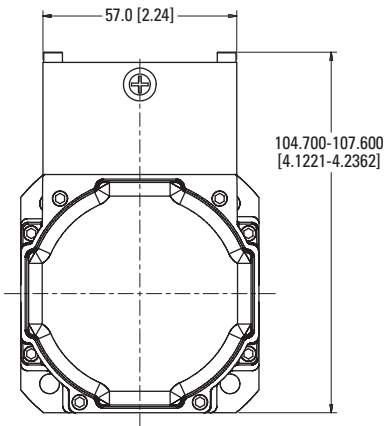
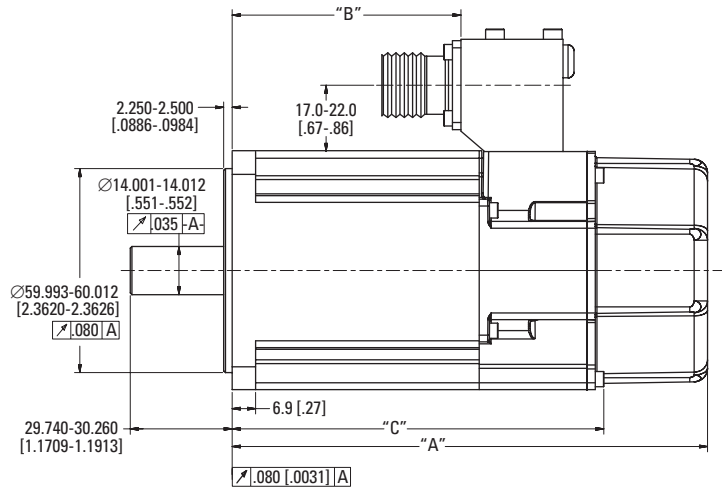
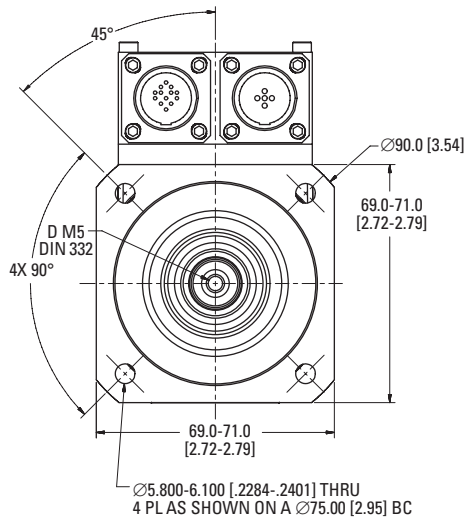

Model	"A"	"B"	"C"	"D"
EKM31	138.74 - 140.74	65.74 - 88.74	108.24 - 110.24	102.74 - 105.74
EKM32	169.74 - 171.74	96.74 - 99.74	139.24 - 141.24	133.74 - 136.74
EKM33	200.74 - 202.74	127.74 - 130.74	170.24 - 172.24	164.74 - 167.74

Dimensions are in mm [inches].
 Product designed in metric.
 English conversions provided for reference only.

*Complete EKM series model nomenclature can be found on page 9.

EKM Servo Motor Specifications

EKM4x Performance Data – Up to 480 Vac (640 Vdc bus) voltage

Performance & Parameters	Symbol	Units	EKM41			EKM42				EKM43			EKM44			
			Windings			Windings				Windings			Windings			
			C	E	H	C	E	G	J	E	G	K	E	G	J	
Max Rated Voltage	-	Vac	480	480	240	480	480	480	240	480	480	240	480	480	480	
		Vdc	640	640	320	640	640	640	320	640	640	320	640	640	640	
Continuous (Stall) Torque ⑤	T _{cs}	N-m	1.88	1.95	1.99	3.28	3.35	3.46	3.49	4.63	4.73	4.83	5.69	5.81	5.93	
		lb-in	16.6	17.3	17.6	29.0	29.7	30.6	30.9	41.0	41.9	42.8	50.4	51.4	52.5	
Continuous (Stall) Current	I _{cs}	A _{rms}	1.46	2.85	5.60	1.40	2.74	4.80	8.40	2.76	4.87	9.60	2.90	5.00	8.80	
		A _{dc}	1.79	3.49	6.86	1.72	3.36	5.88	10.3	3.38	5.97	11.8	3.55	6.13	10.8	
Peak Torque	T _p	N-m	6.05	6.21	6.29	11.0	11.2	11.4	11.5	15.8	16.0	16.2	19.8	20.1	20.3	
		lb-in	53.6	55.0	55.7	97.4	99.2	101	102	140	142	143	175	178	180	
Peak Current	I _p	A _{rms}	5.80	11.4	22.4	5.61	11.0	19.2	33.7	11.0	19.5	38.3	11.4	20.0	35.2	
		A _{dc}	7.11	14.0	27.4	6.87	13.5	23.5	41.3	13.5	23.9	46.9	13.97	24.5	43.1	
Torque Constant at 140°C	K _t	N-m / A _{rms}	1.34	0.71	0.37	2.40	1.26	0.74	0.43	1.72	0.99	0.52	2.04	1.19	0.69	
		lb-in / A _{rms}	11.9	6.29	3.28	21.4	11.2	6.55	3.81	15.2	8.77	4.61	18.1	10.5	6.11	
BEMF Constant ②	K _e	V _{rms} / K _r rpm	86.3	45.6	23.7	154	80.9	47.5	27.5	111	63.9	33.2	132	76.6	44.2	
Resistance ②	R _m	Ohms	21.3	6.02	1.56	27.5	7.78	2.51	0.800	8.61	2.81	0.740	8.04	2.80	0.940	
Inductance ②	mH	mH	66	18	5.0	97	27	9.2	3.1	33	11	2.9	34	12	3.8	
75 VDC	Rated Speed ① ③	N _{rtd}	rpm	-	-	1000	-	-	-	-	-	-	-	-	-	
		T _{rtd}	N-m	-	-	1.92	-	-	-	-	-	-	-	-	-	
			lb-in	-	-	17.0	-	-	-	-	-	-	-	-	-	
		P _{rtd}	kW	-	-	0.20	-	-	-	-	-	-	-	-	-	
Hp	-		-	0.27	-	-	-	-	-	-	-	-	-			
120 Vac (160 Vdc)	Rated Speed ① ③	N _{rtd}	rpm	-	1200	3000	-	-	-	3000	-	-	2500	-	-	
		T _{rtd}	N-m	-	1.81	1.75	-	-	-	2.96	-	-	4.01	-	-	
			lb-in	-	16.0	15.5	-	-	-	26.2	-	-	35.5	-	-	
		P _{rtd}	kW	-	0.23	0.55	-	-	-	0.93	-	-	1.05	-	-	
Hp	-		0.30	0.74	-	-	-	1.25	-	-	1.41	-	-			
240 Vac (320 Vdc)	Rated Speed ① ③	N _{rtd}	rpm	1200	3000	6000	-	1800	3500	6000	1500	2500	6000	1200	2000	4000
		T _{rtd}	N-m	1.81	1.75	1.55	-	3.05	2.83	2.31	4.17	3.93	2.55	5.15	4.83	3.77
			lb-in	16.0	15.5	13.7	-	27.0	25.1	20.4	36.9	34.8	22.6	45.6	42.8	33.4
		P _{rtd}	kW	0.23	0.55	0.97	-	0.57	1.04	1.45	0.65	1.03	1.60	0.65	1.01	1.58
Hp	0.30		0.74	1.30	-	0.77	1.39	1.94	0.88	1.38	2.15	0.87	1.36	2.12		
400 Vac (560 Vdc)	Rated Speed ① ③	N _{rtd}	rpm	3000	6000	-	1500	3500	6000	-	2500	5000	-	2000	4000	6000
		T _{rtd}	N-m	1.70	1.51	-	3.03	2.74	2.28	-	3.85	2.94	-	4.73	3.69	2.68
			lb-in	15.0	13.4	-	26.8	24.3	20.2	-	34.1	26.0	-	41.9	32.7	23.7
		P _{rtd}	kW	0.53	0.95	-	0.48	1.00	1.43	-	1.01	1.54	-	0.99	1.55	1.68
Hp	0.72		1.27	-	0.64	1.35	1.92	-	1.35	2.06	-	1.33	2.07	2.26		
480 Vac (640 Vdc)	Rated Speed ① ③	N _{rtd}	rpm	3500	6000	-	2000	4000	6000	-	3000	6000	-	2500	5000	6000
		T _{rtd}	N-m	1.67	1.51	-	2.95	2.65	2.28	-	3.69	2.50	-	4.49	3.12	2.68
			lb-in	14.8	13.4	-	26.1	23.5	20.2	-	32.7	22.1	-	39.8	27.6	23.7
		P _{rtd}	kW	0.61	0.95	-	0.62	1.11	1.43	-	1.16	1.57	-	1.18	1.63	1.68
Hp	0.82		1.27	-	0.83	1.49	1.92	-	1.55	2.10	-	1.58	2.19	2.26		
Inertia (includes resolver)	J _m	kg-cm ²	0.81			1.5				2.1			2.7			
		lb-in-s ²	7.20E-04			1.30E-03				1.80E-03			2.40E-03			
Brake Inertia (additional)	J _m	kg-cm ²	0.068			0.068				0.068			0.068			
		lb-in-s ²	6.00E-05			6.00E-05				6.00E-05			6.00E-05			
Static Friction (includes shaft seal)	T _f	N-m	0.085			0.097				0.109			0.121			
		lb-in	0.753			0.859				0.965			1.07			
Viscous Damping	K _{dv}	N-m / K _r rpm	0.009			0.013				0.017			0.021			
		lb-in / K _r rpm	0.08			0.12				0.15			0.19			
Weight ⑥	W	Kg	2.55			3.50				4.45			0.54			
		lb	5.60			7.70				9.80			11.9			
Thermal Time Constant	TCT	minutes	13			17				20			24			
Thermal Resistance	R _{th}	°C / Watt	0.97			0.80				0.70			0.65			
Heat Sink Size	Aluminum	inch	10" x 10" x 1/4"			10" x 10" x 1/4"				10" x 10" x 1/4"			10" x 10" x 1/4"			
Poles Pair			5			5				5			5			
Maximum Mechanical Speed ④	N _{max}	rpm	6,000			6,000				6,000			6,000			

Notes:

① Motor Performance based on ΔT = 100°C in a 40°C ambient (winding temp = 140°C) with listed Heat Sink.

② Motor Parameters BEMF, Resistance, and Inductance measured at 25°C.

③ All data referenced to sinusoidal commutation.

④ Speed may be limited by V_{bus}.

⑤ Brake option reduces continuous torque by 0.012 Nm

⑥ Motor weight does not include brake option. EKM4 brake adds 0.63 kg (1.39 lb.).

EKM4x Frame Dimensional Drawings

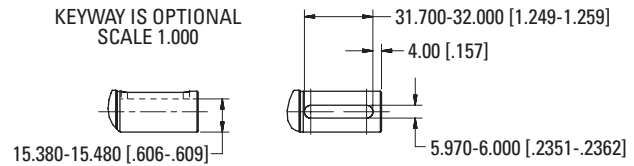
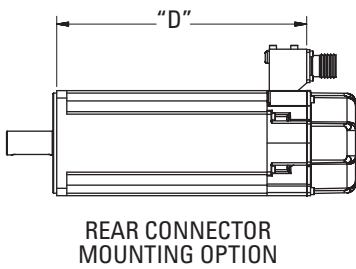
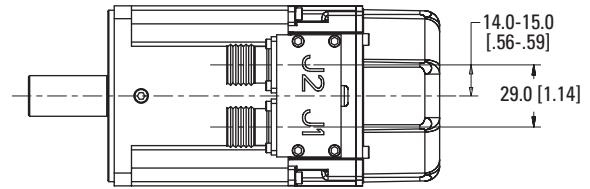
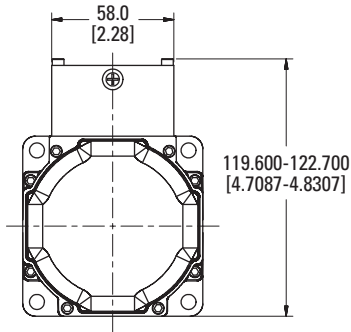
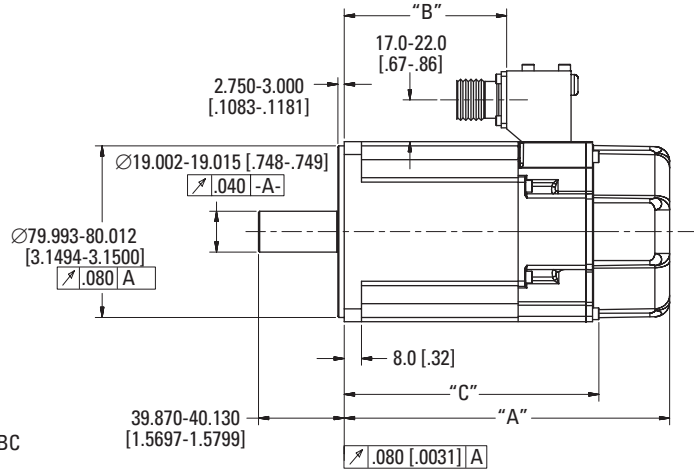
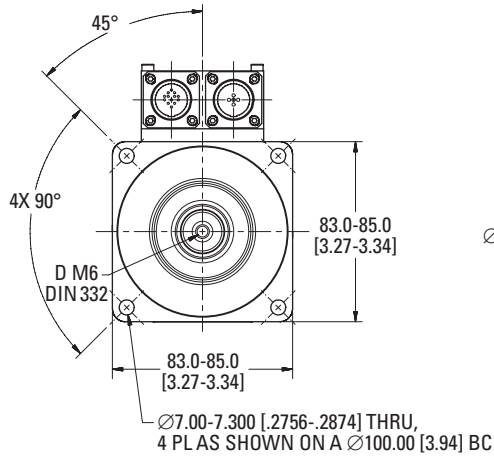

Model	"A"	"B"	"C"	"D"
EKM41	150.75 - 152.75	74.25 - 77.25	117.25 - 119.25	111.25 - 114.25
EKM42	179.75 - 181.75	103.25 - 106.25	146.25 - 148.25	140.25 - 143.25
EKM43	208.75 - 210.75	132.25 - 135.25	175.25 - 177.25	169.25 - 172.25
EKM44	237.75 - 239.75	161.25 - 164.25	204.25 - 206.25	198.25 - 201.25

Dimensions are in mm [inches].
 Product designed in metric.
 English conversions provided for reference only.

*Complete EKM series model nomenclature can be found on page 9.

EKM Servo Motor Specifications

EKM5x Performance Data – Up to 480 Vac (640 Vdc bus) voltage

Performance & Parameters	Symbol	Units	EKM51				EKM52				EKM53				EKM54			
			Windings			E	Windings			E	Windings			E	Windings			E
E	G	K	E	G	K		M	G	K		M	P	G		K	L	N	
Max Rated Voltage	-	Vac	480	480	240	480	480	480	240	480	480	240	240	480	480	400	240	
		Vdc	640	640	320	640	640	640	320	640	640	320	320	640	640	560	320	
Continuous (Stall) Torque ⑤	Tcs	N-m	4.57	4.62	4.77	8.21	8.30	8.47	8.47	11.3	11.5	11.3	11.3	14.2	14.3	14.0	14.0	
		lb-in	40.5	40.9	42.2	72.7	73.5	75.0	75.0	100	102	100	100	125	126	124	124	
Continuous (Stall) Current	Ics	Arms	2.75	4.84	9.4	2.99	4.72	9.30	13.1	4.77	9.40	13.4	19.1	5.00	9.7	12.5	17.8	
		Adc	3.37	5.93	11.5	3.66	5.8	11.4	16.0	5.8	11.5	16.4	23.4	6.13	11.9	15.3	21.8	
Peak Torque	T _p	N-m	11.5	11.6	11.9	21.2	21.4	21.8	21.8	29.6	30.0	29.7	29.7	37.7	38.3	37.4	37.5	
		lb-in	102	102	105	187	189	193	193	262	266	263	263	334	339	331	332	
Peak Current	I _p	Arms	8.24	14.5	28.3	9.00	14.2	27.8	39.4	14.3	28.1	40.3	57.4	14.9	29.2	37.5	53.4	
		Adc	10.1	17.8	34.7	11.0	17.4	34.1	48.3	17.5	34.4	49.4	70.3	18.3	35.8	45.9	65.4	
Torque Constant at 140°C	K _t	N-m / Arms	1.72	0.99	0.52	2.79	1.79	0.93	0.66	2.39	1.24	0.85	0.60	2.88	1.50	1.13	0.80	
		lb-in / Arms	15.2	8.77	4.61	24.7	15.9	8.24	5.84	21.2	11.0	7.53	5.31	25.5	13.3	10.0	7.08	
BEMF Constant ②	K _e	Vrms / Krpm	110	63.6	33.5	179	115	60.1	42.4	154	79.8	54.7	38.4	185	96.6	72.9	51.3	
Resistance ②	R _m	Ohms	8.98	2.87	0.75	8.96	3.70	0.96	0.49	3.97	1.06	0.51	0.28	4.08	1.08	0.65	0.33	
Inductance ②	mH	mH	37	12	3.4	45	19	5.0	2.5	21	5.7	2.7	1.3	23	6.2	3.5	1.8	
75 VDC Rated Speed ① ③	N _{rtd}	rpm	-	-	-	-	-	-	-	-	-	-	-	-	-	-	-	
		N-m	-	-	-	-	-	-	-	-	-	-	-	-	-	-	-	
Rated Torque ① ③ ⑤	T _{rtd}	lb-in	-	-	-	-	-	-	-	-	-	-	-	-	-	-	-	
		kW	-	-	-	-	-	-	-	-	-	-	-	-	-	-	-	
Rated Power ① ③	P _{rtd}	Hp	-	-	-	-	-	-	-	-	-	-	-	-	-	-	-	
		rpm	-	-	2500	-	-	-	-	-	-	-	-	-	-	-	-	-
120 Vac (160 Vdc) Rated Speed ① ③	N _{rtd}	rpm	-	-	4.02	-	-	-	-	-	-	-	-	-	-	-	-	
		N-m	-	-	35.6	-	-	-	-	-	-	-	-	-	-	-	-	
Rated Torque ① ③ ⑤	T _{rtd}	lb-in	-	-	1.05	-	-	-	-	-	-	-	-	-	-	-	-	
		kW	-	-	1.41	-	-	-	-	-	-	-	-	-	-	-	-	
Rated Power ① ③	P _{rtd}	Hp	-	-	1.41	-	-	-	-	-	-	-	-	-	-	-	-	
		rpm	1200	2500	5500	-	1500	3000	4500	1000	2000	3000	5000	-	1800	2500	3500	
240 Vac (320 Vdc) Rated Speed ① ③	N _{rtd}	rpm	1200	2500	5500	-	1500	3000	4500	1000	2000	3000	5000	-	1800	2500	3500	
		N-m	4.28	3.89	2.22	-	7.56	6.67	5.07	10.6	9.97	8.59	5.75	-	12.6	11.4	9.72	
Rated Torque ① ③ ⑤	T _{rtd}	lb-in	37.9	34.4	19.7	-	67.0	59.1	44.9	93.6	88.3	76.1	50.9	-	111	100.7	86.1	
		kW	0.54	1.02	1.28	-	1.19	2.10	2.39	1.11	2.09	2.70	3.01	-	2.37	2.98	3.56	
Rated Power ① ③	P _{rtd}	Hp	0.72	1.37	1.71	-	1.59	2.81	3.20	1.48	2.80	3.62	4.04	-	3.18	3.99	4.78	
		rpm	2500	5000	-	1500	2500	5500	-	2000	4000	-	-	-	1500	3500	4500	-
400 Vac (560 Vdc) Rated Speed ① ③	N _{rtd}	rpm	2500	5000	-	1500	2500	5500	-	2000	4000	-	-	-	1500	3500	4500	
		N-m	3.85	2.49	-	7.48	6.93	3.77	-	9.72	7.52	-	-	-	12.8	9.92	8.00	
Rated Torque ① ③ ⑤	T _{rtd}	lb-in	34.1	22.1	-	66.2	61.4	33.4	-	86.1	66.6	-	-	-	113	87.9	70.8	
		kW	1.01	1.30	-	1.17	1.81	2.17	-	2.04	3.15	-	-	-	2.01	3.64	3.77	
Rated Power ① ③	P _{rtd}	Hp	1.35	1.75	-	1.58	2.43	2.91	-	2.73	4.22	-	-	-	2.69	4.87	5.05	
		rpm	3000	6000	-	2000	3000	6000	-	2400	4500	-	-	-	2000	4000	-	
480 Vac (640 Vdc) Rated Speed ① ③	N _{rtd}	rpm	3000	6000	-	2000	3000	6000	-	2400	4500	-	-	-	2000	4000	-	
		N-m	3.67	1.81	-	7.15	6.53	3.12	-	9.37	6.72	-	-	-	12.2	9.12	-	
Rated Torque ① ③ ⑤	T _{rtd}	lb-in	32.5	16.0	-	63.3	57.8	27.6	-	83.0	59.5	-	-	-	108	80.8	-	
		kW	1.15	1.14	-	1.50	2.05	1.96	-	2.35	3.17	-	-	-	2.55	3.82	-	
Rated Power ① ③	P _{rtd}	Hp	1.55	1.52	-	2.01	2.75	2.63	-	3.16	4.24	-	-	-	3.42	5.12	-	
		Inertia (includes resolver)	Jm	kg-cm ²	3.4			6.2			9.1				12			
Brake Inertia (additional)	Jm	lb-in-s ²	3.00E-03			5.50E-03				8.10E-03				1.10E-02				
		kg-cm ²	0.17			0.17				0.17				0.17				
Static Friction (includes shaft seal)	T _f	lb-in	1.35			1.51				1.66				1.83				
		N-m	0.152			0.170				0.188				0.207				
Viscous Damping	K _{dv}	N-m / krpm	0.033			0.042				0.052				0.061				
		lb-in / krpm	0.29			0.37				0.46				0.54				
Weight ⑥	W	Kg	4.50			6.10				7.68				9.27				
		lb	9.90			13.4				16.9				20.4				
Thermal Time Constant	TCT	minutes	20			24				28				31				
Thermal Resistance	R _{th}	°C / Watt	0.68			0.56				0.50				0.45				
Heat Sink Size	Aluminum	inch	12" x 12" x 1/2"			12 x 12" x 1/2"				12" x 12" x 1/2"				12" x 12" x 1/2"				
Poles Pair			5			5				5				5				
Maximum Mechanical Speed ④	N _{max}	rpm	6,000			6,000				6,000				6,000				

Notes:

① Motor Performance based on ΔT = 100°C in a 40°C ambient (winding temp = 140°C) with listed Heat Sink.

② Motor Parameters BEMF, Resistance, and Inductance measured at 25°C.

③ All data referenced to sinusoidal commutation.

④ Speed may be limited by V_{bus}.

⑤ Brake option reduces continuous torque by: EKM51 = 0.15 Nm, EKM52 = 0.26 Nm, EKM53 = 0.35 Nm, EKM54 = 0.43 Nm

⑥ Motor weight does not include brake option. EKM5 brake adds 1.1 kg (2.42 lb).

EKM5x Frame Dimensional Drawings

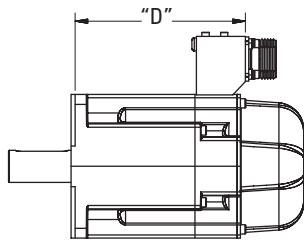
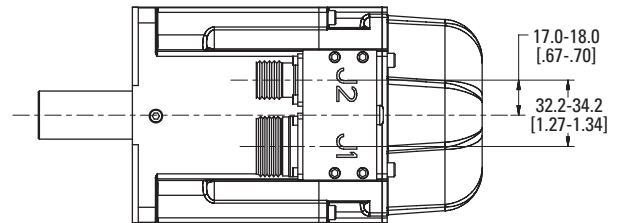
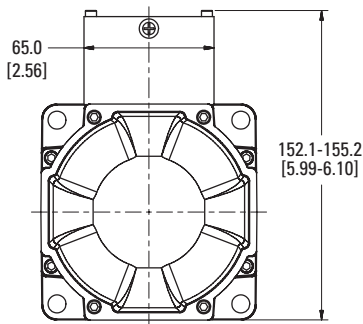
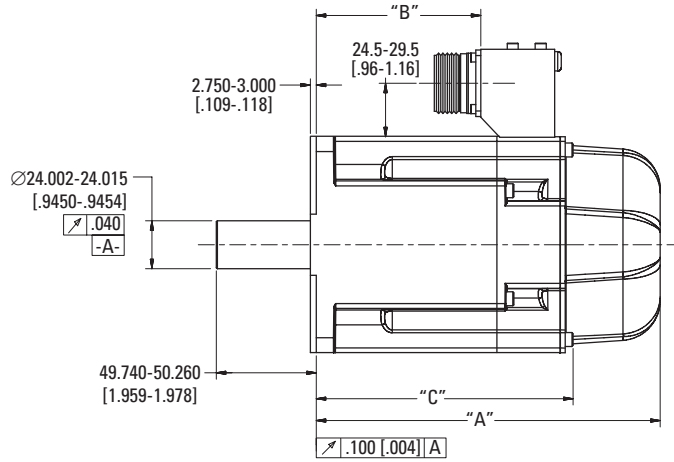
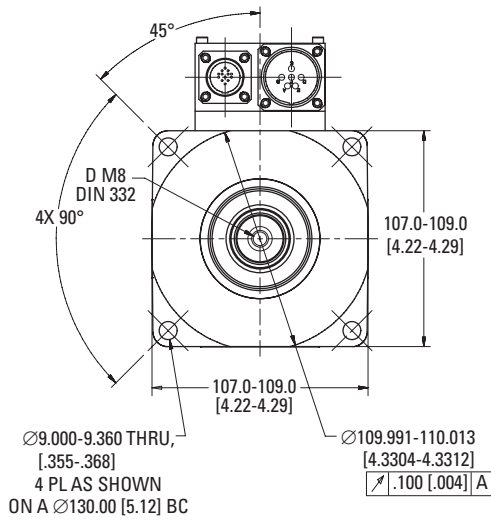

REAR CONNECTOR MOUNTING OPTION

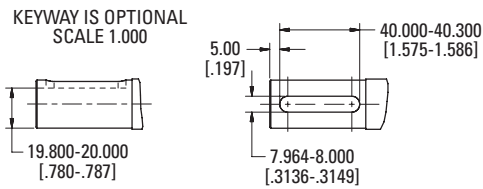

Model	"A"	"B"	"C"	"D"
EKM51	170.95 - 172.95	80.75 - 83.75	125.95 - 127.95	126.75 - 129.75
EKM52	201.95 - 203.95	111.75 - 114.75	156.95 - 158.95	157.75 - 160.75
EKM53	232.95 - 234.95	142.75 - 145.75	187.95 - 189.95	188.75 - 191.75
EKM54	263.95 - 265.95	173.75 - 176.75	218.95 - 220.95	219.75 - 222.75

Dimensions are in mm [inches].
Product designed in metric.
English conversions provided for reference only.

*Complete EKM series model nomenclature can be found on page 9.

EKM Servo Motor Specifications

EKM6x Performance Data – Up to 480 Vac (640 Vdc bus) voltage

Performance & Parameters	Symbol	Units	EKM62				EKM63				EKM64			EKM65			
			Windings				Windings				Windings			Windings			
			G	K	M	P	G	K	M	N	K	L	P	K	M	N	
Max Rated Voltage	-	Vac	480	480	480	240	480	480	480	480	480	480	480	480	480	480	480
		Vdc	640	640	640	320	640	640	640	640	640	640	640	640	640	640	640
Continuous (Stall) Torque ⑤	Tcs	N-m	11.7	12.0	12.0	12.1	16.3	16.6	16.8	16.8	20.6	20.8	20.2	24.6	24.8	24.1	
		In-lb	103	106	106	107	144	147	148	148	182	184	178	217	219	213	
Continuous (Stall) Current	Ics	Arms	4.9	9.6	13.4	18.8	4.5	9.9	13.8	17.4	9.2	12.8	18.6	9.8	13.6	17.8	
		Adc	6.00	11.8	16.4	23.0	5.51	12.1	16.9	21.3	11.3	15.7	22.8	12.01	16.7	21.8	
Peak Torque	Tp	N-m	29.6	29.9	30.0	30.2	41.6	42.4	42.8	42.8	53.3	53.9	52.7	64.3	65.0	63.5	
		In-lb	262	265	266	267	368	375	379	379	472	477	467	569	576	562	
Peak Current	Ip	Arms	14.6	28.7	40.3	56.5	13.4	29.7	41.4	52.2	27.5	38.4	55.9	29.4	40.9	53.3	
		Adc	17.9	35.2	49.4	69.2	16.4	36.4	50.7	63.9	33.7	47.0	68.5	36.0	50.1	65.3	
Torque Constant at 140°C	Kt	N-m / Arms	2.47	1.28	0.91	0.66	3.70	1.71	1.24	0.98	2.28	1.66	1.10	2.54	1.85	1.38	
		In-lb / Arms	21.9	11.3	8.06	5.84	32.8	15.1	11.0	8.68	20.2	14.70	9.74	22.5	16.4	12.2	
BEMF Constant ②	Ke	Vrms / Krpm	159	82.1	58.8	42.2	238	110	79.9	63.3	147	107	71.0	164	119	88.8	
Resistance ②	Rm	Ohms	4.13	1.08	0.57	0.30	5.50	1.14	0.61	0.39	1.41	0.75	0.36	1.35	0.73	0.43	
Inductance ②		mH	32	8.5	4.4	2.2	44	9.3	4.9	3.1	12	6.2	2.8	11	6.1	3.4	
75 VDC	Rated Speed ① ③	Nrt	rpm	-	-	-	-	-	-	-	-	-	-	-	-	-	-
		Trtd	N-m	-	-	-	-	-	-	-	-	-	-	-	-	-	-
120 Vac (160 Vdc)	Rated Torque ① ③ ⑤	Trtd	In-lb	-	-	-	-	-	-	-	-	-	-	-	-	-	-
		Prt	kW	-	-	-	-	-	-	-	-	-	-	-	-	-	-
240 Vac (320 Vdc)	Rated Power ① ③	Prt	Hp	-	-	-	-	-	-	-	-	-	-	-	-	-	-
		Nrt	rpm	-	-	-	-	-	-	-	-	-	-	-	-	-	-
400 Vac (560 Vdc)	Rated Speed ① ③	Nrt	rpm	-	-	-	-	-	-	-	-	-	-	-	-	-	-
		Trtd	N-m	-	-	-	-	-	-	-	-	-	-	-	-	-	-
480 Vac (640 Vdc)	Rated Torque ① ③ ⑤	Trtd	In-lb	-	-	-	-	-	-	-	-	-	-	-	-	-	-
		Prt	kW	-	-	-	-	-	-	-	-	-	-	-	-	-	-
75 VDC	Rated Speed ① ③	Nrt	rpm	-	-	-	-	-	-	-	-	-	-	-	-	-	-
		Trtd	N-m	-	-	-	-	-	-	-	-	-	-	-	-	-	-
120 Vac (160 Vdc)	Rated Torque ① ③ ⑤	Trtd	In-lb	-	-	-	-	-	-	-	-	-	-	-	-	-	-
		Prt	kW	-	-	-	-	-	-	-	-	-	-	-	-	-	-
240 Vac (320 Vdc)	Rated Power ① ③	Prt	Hp	-	-	-	-	-	-	-	-	-	-	-	-	-	-
		Nrt	rpm	-	-	-	-	-	-	-	-	-	-	-	-	-	-
400 Vac (560 Vdc)	Rated Speed ① ③	Nrt	rpm	-	-	-	-	-	-	-	-	-	-	-	-	-	-
		Trtd	N-m	-	-	-	-	-	-	-	-	-	-	-	-	-	-
480 Vac (640 Vdc)	Rated Torque ① ③ ⑤	Trtd	In-lb	-	-	-	-	-	-	-	-	-	-	-	-	-	-
		Prt	kW	-	-	-	-	-	-	-	-	-	-	-	-	-	-
75 VDC	Rated Speed ① ③	Nrt	rpm	-	-	-	-	-	-	-	-	-	-	-	-	-	-
		Trtd	N-m	-	-	-	-	-	-	-	-	-	-	-	-	-	-
120 Vac (160 Vdc)	Rated Torque ① ③ ⑤	Trtd	In-lb	-	-	-	-	-	-	-	-	-	-	-	-	-	-
		Prt	kW	-	-	-	-	-	-	-	-	-	-	-	-	-	-
240 Vac (320 Vdc)	Rated Power ① ③	Prt	Hp	-	-	-	-	-	-	-	-	-	-	-	-	-	-
		Nrt	rpm	-	-	-	-	-	-	-	-	-	-	-	-	-	-
400 Vac (560 Vdc)	Rated Speed ① ③	Nrt	rpm	-	-	-	-	-	-	-	-	-	-	-	-	-	-
		Trtd	N-m	-	-	-	-	-	-	-	-	-	-	-	-	-	-
480 Vac (640 Vdc)	Rated Torque ① ③ ⑤	Trtd	In-lb	-	-	-	-	-	-	-	-	-	-	-	-	-	-
		Prt	kW	-	-	-	-	-	-	-	-	-	-	-	-	-	-
75 VDC	Rated Speed ① ③	Nrt	rpm	-	-	-	-	-	-	-	-	-	-	-	-	-	-
		Trtd	N-m	-	-	-	-	-	-	-	-	-	-	-	-	-	-
120 Vac (160 Vdc)	Rated Torque ① ③ ⑤	Trtd	In-lb	-	-	-	-	-	-	-	-	-	-	-	-	-	-
		Prt	kW	-	-	-	-	-	-	-	-	-	-	-	-	-	-
240 Vac (320 Vdc)	Rated Power ① ③	Prt	Hp	-	-	-	-	-	-	-	-	-	-	-	-	-	-
		Nrt	rpm	-	-	-	-	-	-	-	-	-	-	-	-	-	-
400 Vac (560 Vdc)	Rated Speed ① ③	Nrt	rpm	-	-	-	-	-	-	-	-	-	-	-	-	-	-
		Trtd	N-m	-	-	-	-	-	-	-	-	-	-	-	-	-	-
480 Vac (640 Vdc)	Rated Torque ① ③ ⑤	Trtd	In-lb	-	-	-	-	-	-	-	-	-	-	-	-	-	-
		Prt	kW	-	-	-	-	-	-	-	-	-	-	-	-	-	-
75 VDC	Rated Speed ① ③	Nrt	rpm	-	-	-	-	-	-	-	-	-	-	-	-	-	-
		Trtd	N-m	-	-	-	-	-	-	-	-	-	-	-	-	-	-
120 Vac (160 Vdc)	Rated Torque ① ③ ⑤	Trtd	In-lb	-	-	-	-	-	-	-	-	-	-	-	-	-	-
		Prt	kW	-	-	-	-	-	-	-	-	-	-	-	-	-	-
240 Vac (320 Vdc)	Rated Power ① ③	Prt	Hp	-	-	-	-	-	-	-	-	-	-	-	-	-	-
		Nrt	rpm	-	-	-	-	-	-	-	-	-	-	-	-	-	-
400 Vac (560 Vdc)	Rated Speed ① ③	Nrt	rpm	-	-	-	-	-	-	-	-	-	-	-	-	-	-
		Trtd	N-m	-	-	-	-	-	-	-	-	-	-	-	-	-	-
480 Vac (640 Vdc)	Rated Torque ① ③ ⑤	Trtd	In-lb	-	-	-	-	-	-	-	-	-	-	-	-	-	-
		Prt	kW	-	-	-	-	-	-	-	-	-	-	-	-	-	-
75 VDC	Rated Speed ① ③	Nrt	rpm	-	-	-	-	-	-	-	-	-	-	-	-	-	-
		Trtd	N-m	-	-	-	-	-	-	-	-	-	-	-	-	-	-
120 Vac (160 Vdc)	Rated Torque ① ③ ⑤	Trtd	In-lb	-	-	-	-	-	-	-	-	-	-	-	-	-	-
		Prt	kW	-	-	-	-	-	-	-	-	-	-	-	-	-	-
240 Vac (320 Vdc)	Rated Power ① ③	Prt	Hp	-	-	-	-	-	-	-	-	-	-	-	-	-	-
		Nrt	rpm	-	-	-	-	-	-	-	-	-	-	-	-	-	-
400 Vac (560 Vdc)	Rated Speed ① ③	Nrt	rpm	-	-	-	-	-	-	-	-	-	-	-	-	-	-
		Trtd	N-m	-	-	-	-	-	-	-	-	-	-	-	-	-	-
480 Vac (640 Vdc)	Rated Torque ① ③ ⑤	Trtd	In-lb	-	-	-	-	-	-	-	-	-	-	-	-	-	-
		Prt	kW	-	-	-	-	-	-	-	-	-	-	-	-	-	-
75 VDC	Rated Speed ① ③	Nrt	rpm	-	-	-	-	-	-	-	-	-	-	-	-	-	-
		Trtd	N-m	-	-	-	-	-	-	-	-	-	-	-	-	-	-
120 Vac (160 Vdc)	Rated Torque ① ③ ⑤	Trtd	In-lb	-	-	-	-	-	-	-	-	-	-	-	-	-	-
		Prt	kW	-	-	-	-	-	-	-	-	-	-	-	-	-	-
240 Vac (320 Vdc)	Rated Power ① ③	Prt	Hp	-	-	-	-	-	-	-	-	-	-	-	-	-	-
		Nrt	rpm	-	-	-	-	-	-	-	-	-	-	-	-	-	-
400 Vac (560 Vdc)	Rated Speed ① ③	Nrt	rpm	-	-	-	-	-	-	-	-	-	-	-	-	-	-
		Trtd	N-m	-	-	-	-	-	-	-	-	-	-	-	-	-	-
480 Vac (640 Vdc)	Rated Torque ① ③ ⑤	Trtd	In-lb	-	-	-	-	-	-	-	-	-	-	-	-	-	-
		Prt	kW	-	-	-	-	-	-	-	-	-	-	-	-	-	-
75 VDC	Rated Speed ① ③	Nrt	rpm	-	-	-	-	-	-	-	-	-	-	-	-	-	-
		Trtd	N-m	-	-	-	-	-	-	-	-	-	-	-	-	-	-
120 Vac (160 Vdc)	Rated Torque ① ③ ⑤	Trtd	In-lb	-	-	-	-	-	-	-	-	-	-	-	-	-	-
		Prt	kW	-	-	-	-	-	-	-	-	-	-	-	-	-	-
240 Vac (320 Vdc)	Rated Power ① ③	Prt	Hp	-	-	-	-	-	-	-	-	-	-	-	-	-	-
		Nrt	rpm	-	-	-	-	-	-	-	-	-	-	-	-	-	-
400 Vac (560 Vdc)	Rated Speed ① ③	Nrt	rpm	-	-												

EKM6x Frame Dimensional Drawings

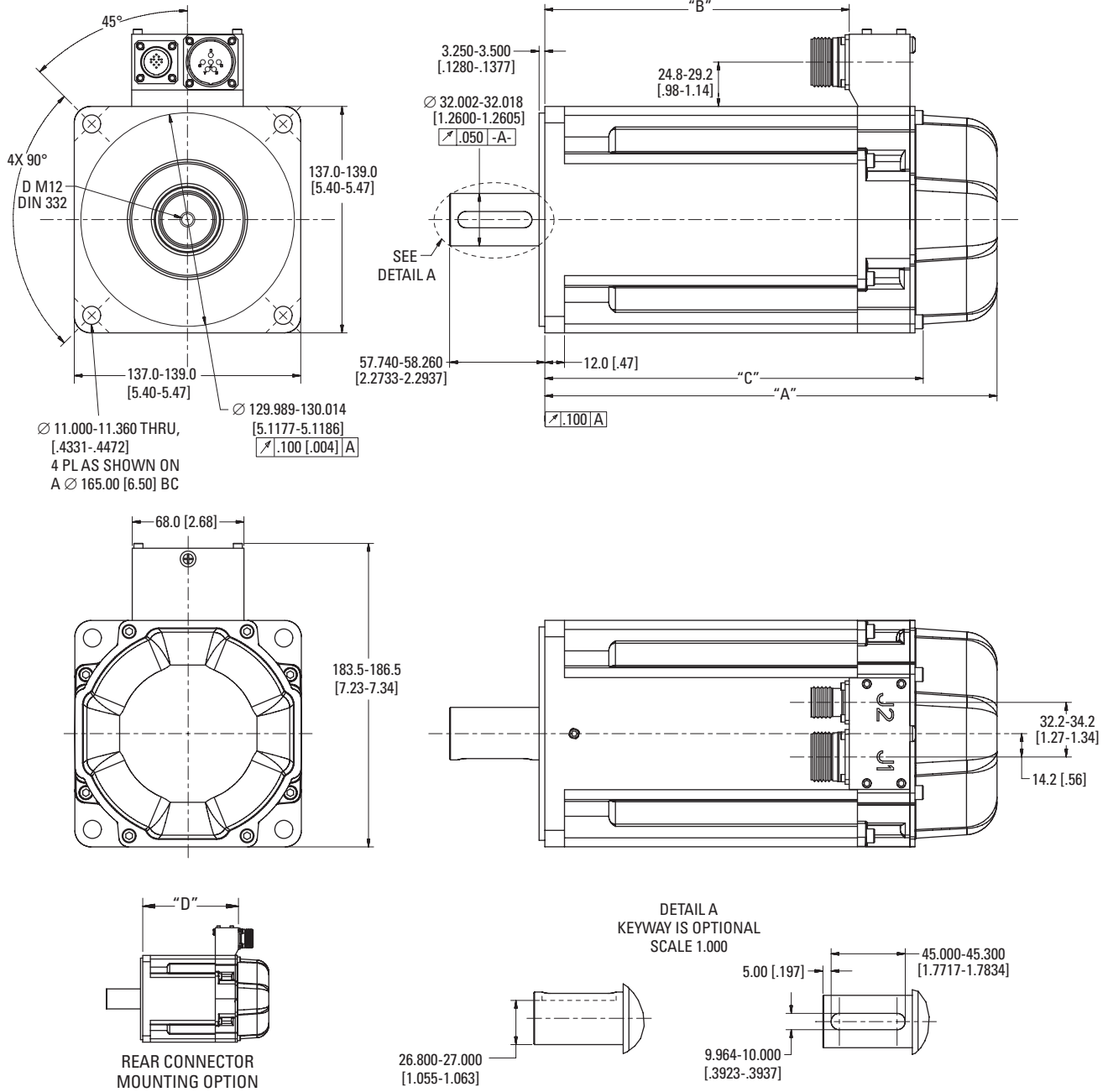

Model	"A"	"B"	"C"	"D"
EKM62	199.55 - 201.55	109.00 - 112.00	154.6 - 156.6	135.7 - 138.8
EKM63	224.55 - 226.55	134.00 - 137.00	179.6 - 181.6	160.7 - 163.8
EKM64	249.55 - 251.55	159.00 - 162.00	204.6 - 206.6	185.7 - 188.8
EKM65	274.55 - 276.55	184.00 - 187.00	229.6 - 231.6	210.7 - 213.8

Dimensions are in mm [inches].
 Product designed in metric.
 English conversions provided for reference only.

*Complete EKM series model nomenclature can be found on page 9.

EKM Servo Motor Specifications

EKM7x Performance Data – Up to 480 Vac (640 Vdc bus) voltage

Performance & Parameters	Symbol	Units	EKM72			EKM73		EKM74	
			Windings			Windings		Windings	
			K	M	P	M	P	L	P
Max Rated Voltage	-	Vac	480	480	480	480	480	480	480
		Vdc	640	640	640	640	640	640	640
Continuous (Stall) Torque ⑤	Tcs	N-m	29.5	29.8	29.2	41.8	41.4	52.8	52.3
		lb-in	261	263	258	370	366	467	463
Continuous (Stall) Current	Ics	Arms	9.30	13.0	18.7	13.6	19.5	12.9	18.5
		Adc	11.4	15.9	22.9	16.7	23.9	15.8	22.7
Peak Torque	Tp	N-m	79.0	79.5	78.3	113	111	143	142
		lb-in	700	704	693	1001	983	1266	1258
Peak Current	Ip	Arms	27.8	38.9	56.1	40.8	58.6	38.7	55.5
		Adc	34.1	47.7	68.7	50.0	71.8	47.4	68.0
Torque Constant at 140°C	Kt	N-m / Arms	3.23	2.33	1.58	3.10	2.13	4.14	2.84
		lb-in / Arms	28.6	20.6	14.0	27.5	18.9	36.7	25.2
BEMF Constant ②	Ke	Vrms / Krpm	208	150	102	200	137	266	183
Resistance ②	Rm	Ohms	1.36	0.69	0.35	0.76	0.38	0.93	0.47
Inductance ②	mH	mH	21	11	5.0	12	5.9	16	7.7
75 VDC	Rated Speed ① ③	Nrtd	-	-	-	-	-	-	-
		Trtd	-	-	-	-	-	-	-
120 Vac (160 Vdc)	Rated Torque ① ③ ⑤	N-m	-	-	-	-	-	-	-
		lb-in	-	-	-	-	-	-	-
240 Vac (320 Vdc)	Rated Power ① ③	kW	-	-	-	-	-	-	-
		Hp	-	-	-	-	-	-	-
400 Vac (560 Vdc)	Rated Speed ① ③	Nrtd	-	-	1800	-	1300	-	-
		Trtd	-	-	23.6	-	34.5	-	-
480 Vac (640 Vdc)	Rated Torque ① ③ ⑤	N-m	-	-	209	-	305	-	-
		lb-in	-	-	209	-	305	-	-
75 VDC	Rated Power ① ③	kW	-	-	4.44	-	4.69	-	-
		Hp	-	-	5.95	-	6.29	-	-
120 Vac (160 Vdc)	Rated Speed ① ③	Nrtd	1500	2000	3000	1500	2400	1200	1800
		Trtd	24.9	23.4	19.9	33.6	28.3	43.3	39.4
240 Vac (320 Vdc)	Rated Torque ① ③ ⑤	N-m	220	207	176	297	250	383	348
		lb-in	220	207	176	297	250	383	348
400 Vac (560 Vdc)	Rated Power ① ③	kW	3.90	4.89	6.24	5.27	7.10	5.43	7.42
		Hp	5.23	6.56	8.36	7.06	9.52	7.29	9.94
480 Vac (640 Vdc)	Rated Speed ① ③	Nrtd	1800	2500	3500	1800	2800	1400	2000
		Trtd	23.8	21.9	18.0	31.9	26.1	41.3	35.7
75 VDC	Rated Torque ① ③ ⑤	N-m	210	194	159	282	231	365	316
		lb-in	210	194	159	282	231	365	316
120 Vac (160 Vdc)	Rated Power ① ③	kW	4.48	5.72	6.58	6.00	7.64	6.05	7.47
		Hp	6.00	7.67	8.82	8.05	10.24	8.11	10.01
Inertia (includes resolver)	Jm	kg-cm ²	65			92		120	
		lb-in-s ²	0.057			0.082		0.110	
Brake Inertia (additional)	Jm	kg-cm ²	1.64			1.64		1.64	
		lb-in-s ²	1.46E-03			1.46E-03		1.46E-03	
Static Friction (includes shaft seal)	Tf	N-m	0.41			0.49		0.58	
		lb-in	3.63			4.34		5.14	
Viscous Damping	Kdv	N-m / krpm	0.06			0.13		0.2	
		lb-in / krpm	0.5			1.2		1.8	
Weight ⑥	W	Kg	20.0			27.0		33.9	
		lb	44.0			59.4		74.6	
Thermal Time Constant	TCT	minutes	46			53		60	
Thermal Resistance	Rth	°C / Watt	0.39			0.33		0.30	
Heat Sink Size	Aluminum	inch	18" x 18" x 1/2"			18" x 18" x 1/2"		18" x 18" x 1/2"	
Poles Pair			5			5		5	
Maximum Mechanical Speed ④	Nmax	rpm	6,000			6,000		6,000	

Notes:

① Motor Performance based on $\Delta T = 100^\circ\text{C}$ in a 40°C ambient (winding temp = 140°C) with listed Heat Sink.

② Motor Parameters BEMF, Resistance, and Inductance measured at 25°C .

③ All data referenced to sinusoidal commutation.

④ Speed may be limited by Vbus.

⑤ Brake option reduces continuous torque by 1.0 N-m

⑥ Motor weight does not include brake option. EKM7 brake adds 2.9 kg (6.38 lb).

EKM7x Frame Dimensional Drawings

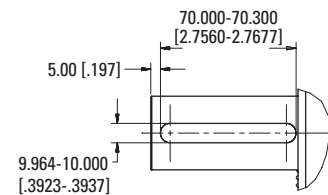
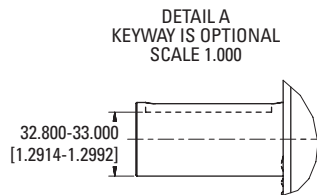
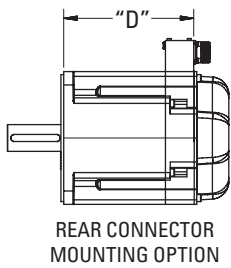
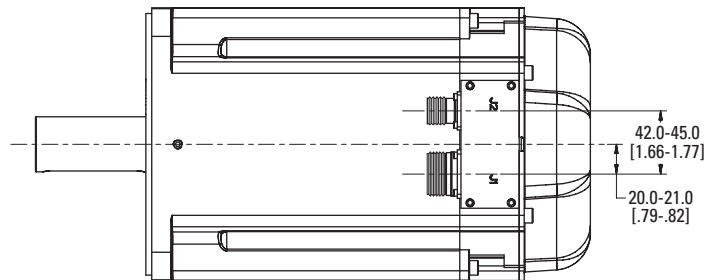
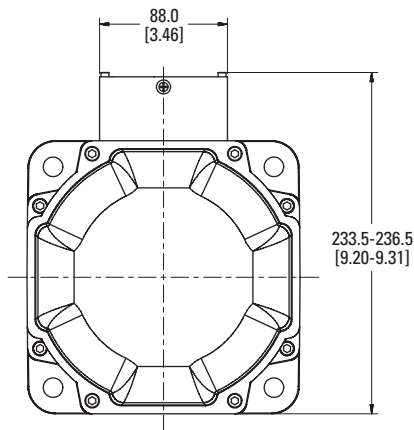
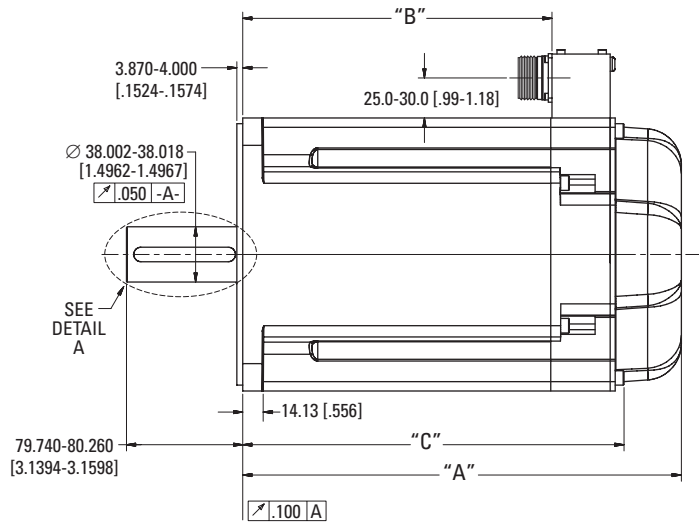
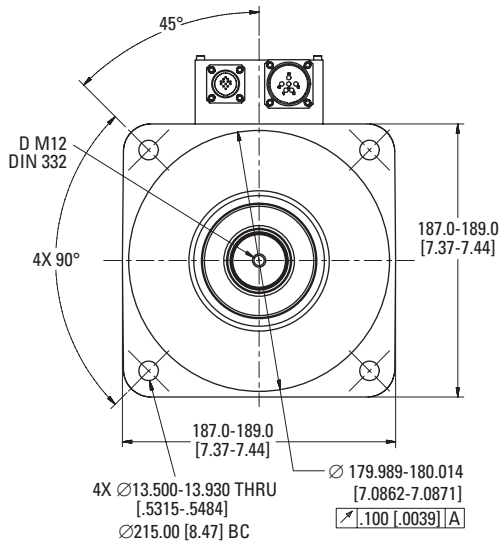

Model	"A"	"B"	"C"	"D"
EKM72	232.92 - 234.92	142.85 - 145.29	193.42 - 195.42	182.85 - 185.29
EKM73	266.92 - 268.92	176.85 - 179.29	227.42 - 229.42	216.85 - 219.29
EKM74	300.92 - 302.92	210.85 - 213.29	261.42 - 263.42	250.85 - 253.29

Dimensions are in mm [inches].
 Product designed in metric.
 English conversions provided for reference only.

*Complete EKM series model nomenclature can be found on page 9.

L10 Bearing Fatigue and Shaft Loading

L10 Bearing Fatigue

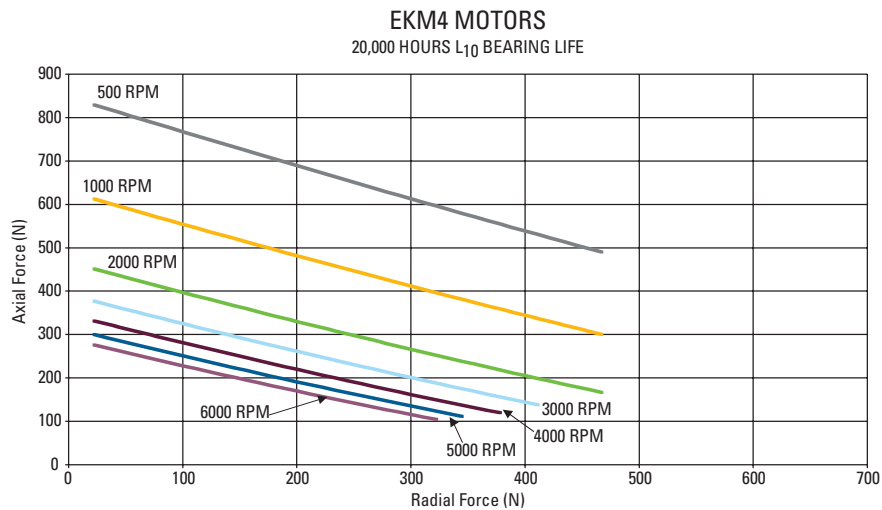
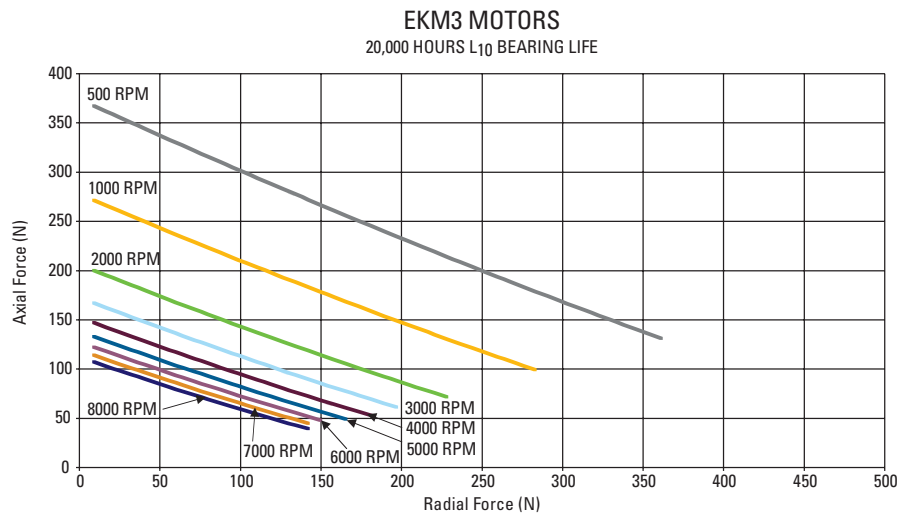
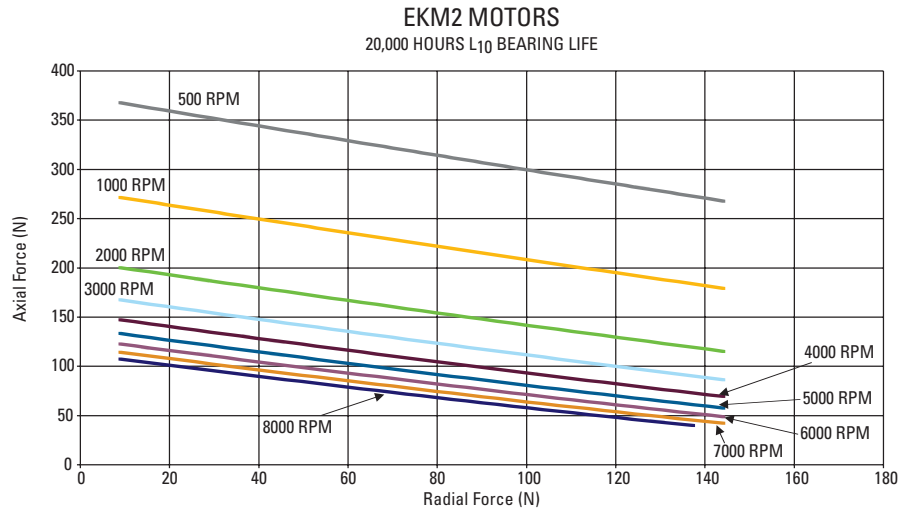

L10 Bearing Fatigue

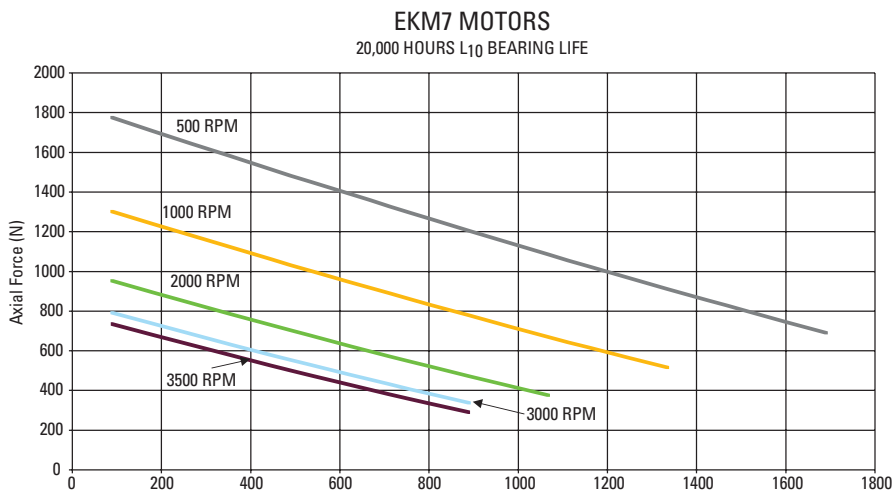
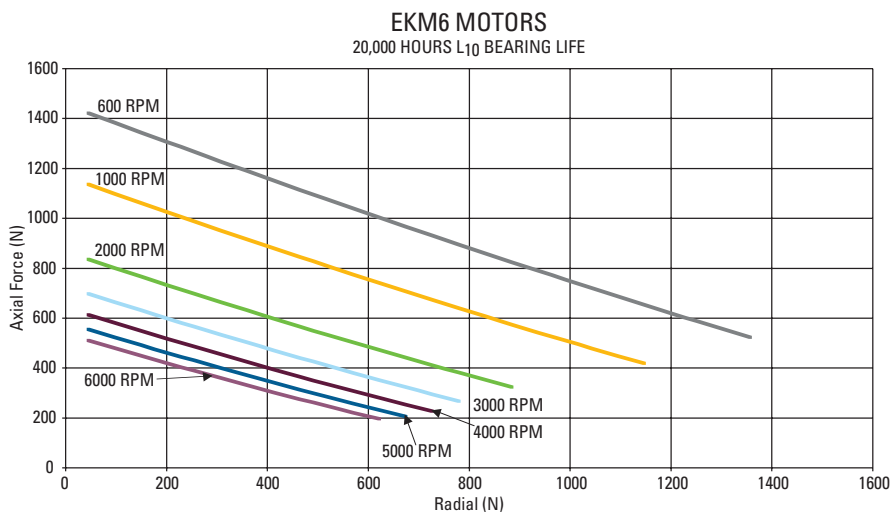
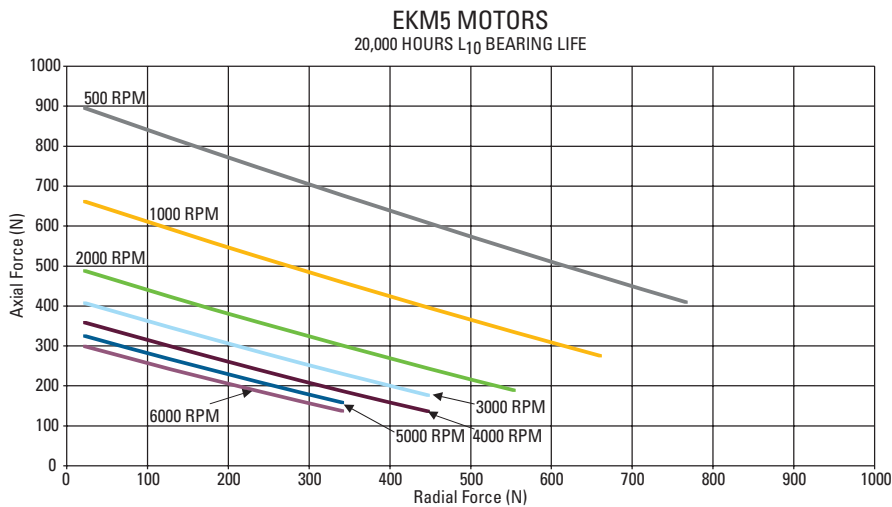

Shaft Loading

Motor	Max. Radial Force (N)	Max. Axial Force (N)
AKM1	48	200
AKM2	150	600
AKM3	340	600
AKM4	500	1400
AKM5	830	1740
AKM6	1940	2200
AKM7	2300	3000
AKM8	2752	4750

The maximum radial load ratings reflect the following assumptions:

1. Motors are operated with peak torque of the longest member of the frame size.
2. Fully reversed load applied to the end of the smallest diameter standard mounting shaft extension. Excluding AKM4X-EK which is rated at 240 N max. radial force.
3. Infinite life with 99% reliability.
4. Safety factor = 2.

EKM Motor Resolver Feedback

Phasing Diagram - All Motors

General notes:

- When motor is rotated CW (viewed from drive shaft end), these waveforms result:
Voltage U, leads V, leads W. Voltage U-W leads Voltage V-W by 60° electrical.
- PTC thermistor (155°C ± 5°C switching temperature) installed. Resistance at 25°C: ≤550 ohms. Switching Resistance: ≥1330 ohms within ±5°C of switch temperature.
- Standard outline drawings showing mounting dimensions and standard winding information are available on our website at www.kollmorgen.com or by calling Kollmorgen Customer Support at 1-540-633-3545, or through email at support@kollmorgen.com.

Motor Winding Configuration

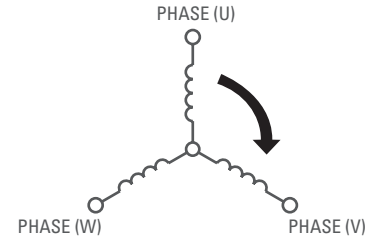

Resolver (Primary Feedback)

Resolver Data	Units	EKM 2, 3, 4	EKM 5, 6, 7
Type		1 Speed	1 Speed
Input Voltage	V _{rms}	7.0	8.0
Frequency	k Hz	10	8.0
Input Current Max.	mA	32	52
Transformation Ratio	10%	0.5	0.5
Null Voltage	mV _{rms}	50	30
Max. Error (pk-pk)	MINS.	16	20
Phase Shift	DEG	-9°	-3°
Operating Temperature	°C	-55° to 155°	-55° to 155°
Rotor Inertia Max.	kg cm ²	0.046	0.497

Resolver Winding Configuration

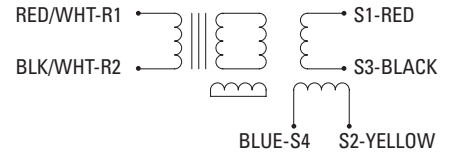

$$E_{R1-R2} = E \sin(\omega T)$$

$$E_{S1-S3} = K E_{R1-R2} \sin \theta$$

$$E_{S2-S4} = K E_{R1-R2} \cos \theta$$

Resolver Alignment

With positive DC current into phase W and out of phase V (U floats) the resolver is aligned to electrical ±5 counts. ie. Voltage S1-S3 set to null voltage S2-S4 max in phase with reference (R1-R2).

Failsafe, Holding Brake

The holding brake is designed to provide static holding torque to the motor shaft with the brake coil de-energized. The brake must first be released (coil energized) prior to commanding motor rotation as determined by its drop-out time. The brake is intended for holding or “parking” of a stationary motor. Not intended for dynamic braking. There should be absolutely no motion of the rotor when power is removed from the brake coil.

EKM Motor Brake Specifications

Motor Family	Minimum Static Torque @120°C		Weight		Power Consumption @24V, 20°C	Current @24V, 20°C	Inertia		Closing Time (engage)	Opening Time (release)	Backlash ²	
	N-m	lb-in	Kg	lbs			Watts ±7%	ADC			kg-cm ²	lb-in-sec ²
EKM2	1.42	12.6	0.27	0.59	8.4	0.35	0.011	0.97E-05	18	20	1.01	0.46
EKM3	2.5	22.1	0.35	0.77	10.1	0.42	0.011	0.97E-05	10	25	1.01	0.46
EKM4	5.3	46.9	0.63	1.39	12.8	0.53	0.068	6.02E-05	15	35	0.81	0.37
EKM5	14.5	128	1.1	2.42	19.5	0.82	0.173	1.53E-04	15	80	0.71	0.31
EKM6	25	221	2	4.4	25.7	1.07	0.605	5.35E-04	20	105	0.51	0.24
EKM7	53	469	2.9	6.38	35.6	1.48	1.649	1.46E-03	35	110	0.44	0.20

1. Operating Voltage: 24 Vdc +/- 10%.

2. Maximum backlash is calculated using worst-case tolerancing, and typical backlash is calculated using statistical tolerancing.

EKM Motor Connector Pinouts

Connector Options – Customer is responsible for cabling. Please reference the information below to select the proper mating connector.

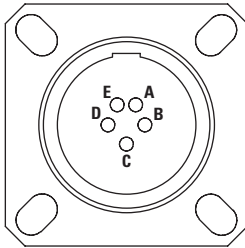

Power Connector

Manufacturer P/N: D38999/20FB5PN (Amphenol)
EKM 2X, 3X

Pin	Function	Color
A	Motor A	Blue
B	Motor B	Brown
C	Motor C	Violet
D	Ground	Green/Yellow
E	Filler Pin	N/C

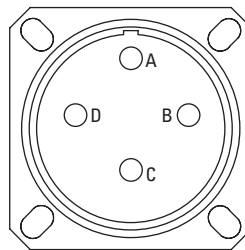

Power Connector

Manufacturer P/N: D38999/20FC4PN (Amphenol)
EKM 4X

Pin	Function	Color
A	Motor A	Blue
B	Motor B	Brown
C	Motor C	Violet
D	Ground	Green/Yellow

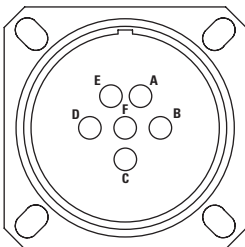

Power Connector

Manufacturer P/N: D38999/20FE6PN (Amphenol)
EKM 5X, 6X, 7X

Pin	Function	Color
A	Motor A	Blue
B	Motor B	Brown
C	Motor C	Violet
D	Ground	Green/Yellow
E	Filler Pin	N/C
F	Filler Pin	N/C

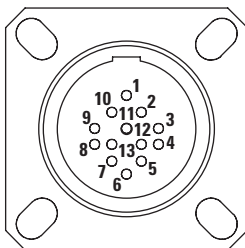

Feedback Signal Connector

Manufacturer P/N: D38999/20FB35PN (Amphenol)
EKM 2X, 3X, 4X, 5X, 6X, 7X

Pin	Function	Color
1	Filler Pin	N/C
2	Thermistor	Blue
3	S4: COS (-)	Blue
4	S3: SIN (-)	Black
5	R2: REF (-)	Black/White
6	Thermistor	Black
7	S2: COS (+)	Yellow
8	S1: SIN (+)	Red
9	R1: REF (+)	Red/White
10	Filler Pin	N/C
11	Brake (+)	Black
12	Brake (-)	Black
13	Filler Pin	N/C



Notes

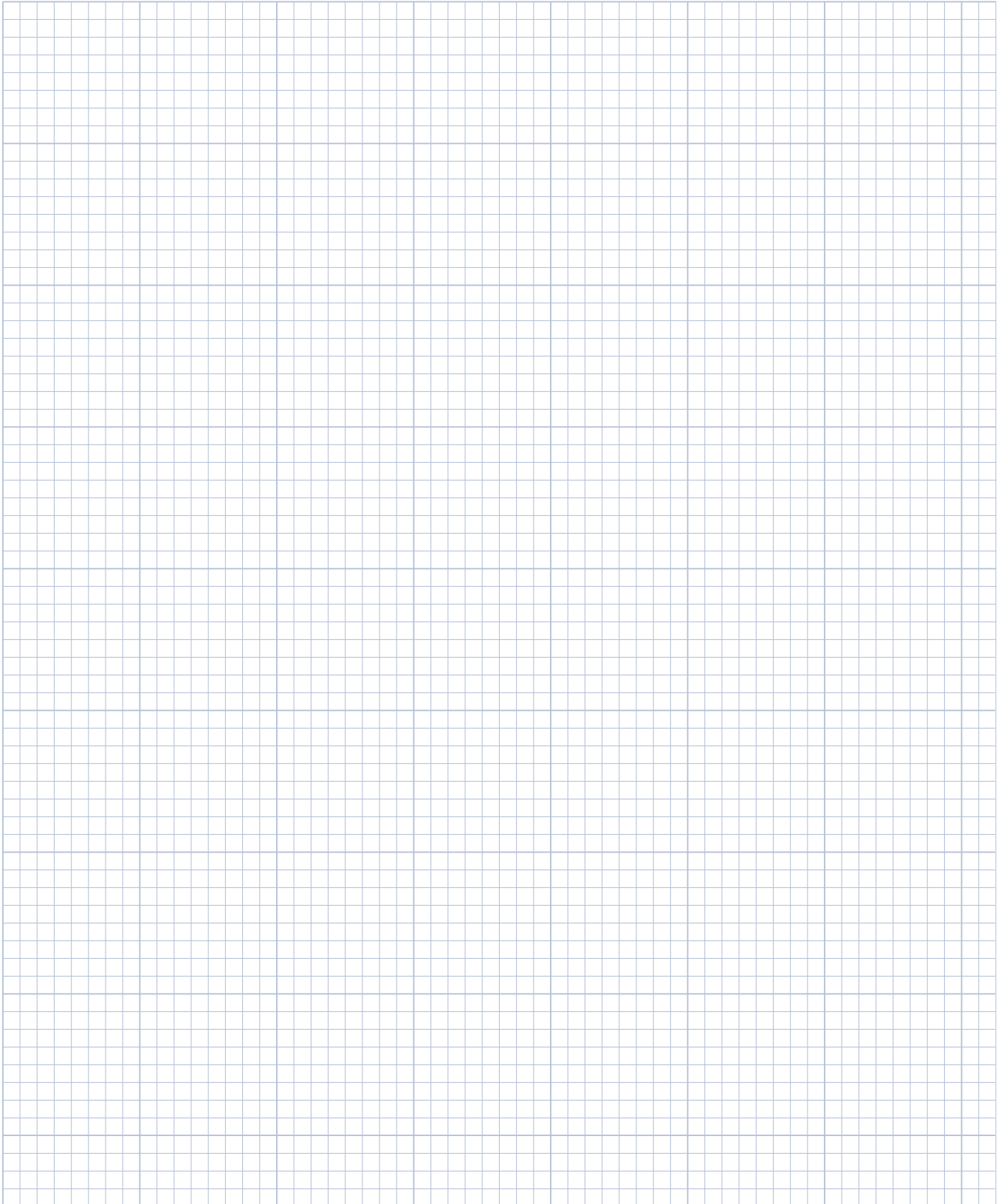

0.125 inch divisions

Complete Motion and Automation Solutions

The highest performance and the right fit for any application.



Online Design Tools

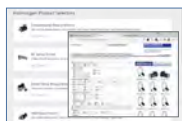

Product Selector

Quickly choose the ideal products for your application needs.



Motioneering[®]

Size your motion system based on application requirements and motion profiles.

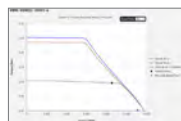

Performance Curve Generator

Optimize housed and frameless motor windings based on power and environmental factors.



3D Models

Visualize products in 3D and download CAD files for use in your design.



Stepper Optimizer

Interactively choose the most efficient stepper solution for your application.



AKD2G Safe Dynamic Brake Calculator

Specify and size the right braking components while saving development time.



Learn more and try our design tools now.

More Expertise for a More Successful Machine

Our global engineering, service and support network provides deep knowledge of all the major industries that rely on advanced motion control and automation technology. We offer world-class engineering expertise, self-service design tools, personalized field service, and easy access to our design, application and manufacturing centers in strategic locations across the globe.

About Kollmorgen

Kollmorgen, a Regal Rexnord brand, has more than 100 years of motion experience, proven in the industry's highest-performing, most reliable motors, drives, linear actuators, AGV (Automated Guided Vehicle) control solutions, and automation control platforms. We deliver breakthrough solutions that combine exceptional performance, reliability and ease of use, giving machine builders an irrefutable marketplace advantage.

Australian Distributor for Kollmorgen



hello@motion-werkz.com
www.motion-werkz.com
Call us: 0499 885 772

KOLLMORGEN

A REGAL REXNORD BRAND

www.kollmorgen.com

Specifications are subject to change without notice. It is the responsibility of the product user to determine the suitability of this product for a specific application. All trademarks are the property of their respective owners

© 2025 Kollmorgen Corporation. All rights reserved