

POWERPAC® K/N Series Stepper Motor

Selection Guide

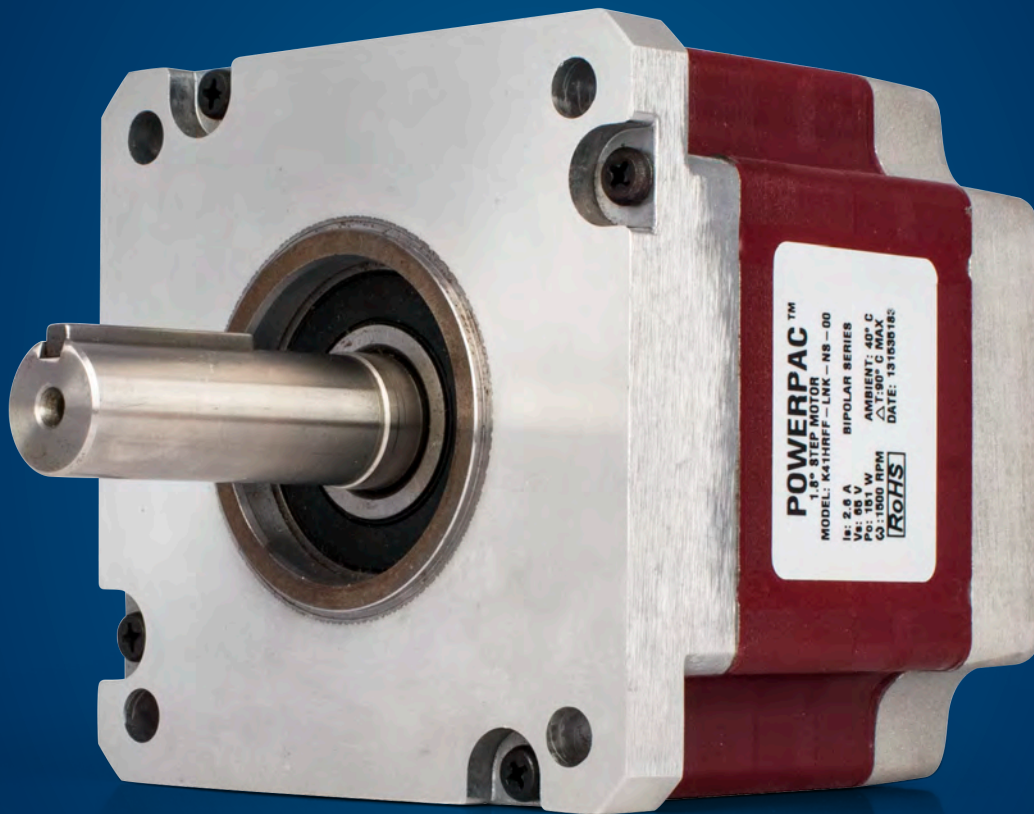

Australian Distributor for Kollmorgen



hello@motion-werkz.com
www.motion-werkz.com
Call us: 0499 885 772

KOLLMORGEN

A REGAL REXNORD BRAND

Kollmorgen: Your Partner, In Motion.

Every solution comes from a real understanding of the challenges facing machine designers and users.

Innovators consistently rate Kollmorgen as one of their best motion systems manufacturing partners. Whether you are looking for classic servo motors, direct-drive servo motors, stepper motors, drives & amplifiers, gearing, actuation, or multi-axis motion controllers, Kollmorgen is one of the few companies in the world that actually designs and manufactures all of these products.

Our customers are leaders in many industries such as Aerospace & Defense, Printing, Packaging & Converting, Food & Beverage Processing, Medical Imaging, In Vitro Diagnostics & Laboratory Automation, Pharmaceutical Manufacturing, Material Forming and Cutting, Oil & Gas, and Robotics. Kollmorgen is also a leader in Warehouse Automation, including complete AGV systems, software, awareness and autonomy.

Our Automation Solutions can be found on Mars and in space, ships and submarines, O&G drilling and metrology, surgical robots and laser eye surgery, even inside artificial hearts. These are just a few applications that demand high-performance and high-quality while satisfying their specific needs.

Because motion matters, it's our focus: Motion can distinctly differentiate a specific machine and deliver a marketplace advantage by increasing its performance and dramatically improving Overall Equipment Effectiveness (OEE).

High-performance motion can make your customer's machine more reliable and energy-efficient, enhance accuracy and improve operator safety. Motion also represents endless possibilities for innovation.

We've always understood this potential, and thus have kept motion at our core and in our Vision, Mission & Values, relentlessly developing products that offer precise control of torque, velocity and position accuracy in machines that rely on complex motion.

How To Use This Selection Guide:

This guide covers the technical information required to select and order K/N Series stepper motors. Select the proper motor using one of the following procedures:

- » If you're already familiar with these motors and the available options, refer to the Model Nomenclature on pg. 7 to verify the part number and corresponding motor options prior to order.
- » If you're not familiar with K/N motors and available options: first refer to the General Specifications, pg. 6. To further evaluate individual winding specifications refer to the Drawings and Performance Data. After all the technical parameters and options are determined, construct a part number using the Model Nomenclature (pg. 7).

Where To Order:

Kollmorgen utilizes an experienced channel of Authorized High-Tech Distributors (AHTDs) to assist our customers with applications, sizing and selection, ordering, and technical support. Visit our Distributor Locator to find locally available distributors.
www.kollmorgen.com/enus/where-to-buy/

Kollmorgen Customer Service Representatives are also available by phone or e-mail and can assist in selecting and contacting local distributors.

- » North America: 1-540-633-3545,
support@kollmorgen.com
- » Europe/Middle East/Africa: +49 (0) 2102 9394 0,
think@kollmorgen.com
- » Asia: +86-400 661 2802,
sales.china@kollmorgen.com

Table of Contents

▶ POWERPAC® K/N Series Stepper Motors	4
General Specifications	6
K / N Motor Nomenclature	7
K / N Motor Connection Information	8
▶ K3 / N3 Series Stepper Motors	10
K3 / N3 Motor Dimensional Drawings	10
K3 / N3 Motor Performance Data	14
K3 / N3 Motor Performance Curves	18
▶ K4 / N4 Series Stepper Motors	22
K4 / N4 Motor Dimensional Drawings	22
K4 / N4 Motor Performance Data	24
K4 / N4 Motor Performance Curves	28
▶ K / N Encoder Options	30

Trademarks

AKD is a registered trademark of Kollmorgen Corporation
AKM is a registered trademark of Kollmorgen Corporation
Cartridge DDR is a registered trademark of Kollmorgen Corporation
EnDat is a registered trademark of Dr. Johannes Heidenhain GmbH
EtherCAT is a registered trademark and patented technology, licensed by Beckhoff Automation GmbH
Ethernet/IP is a registered trademark of ODVA, Inc.
Ethernet/IP Communication Stack: copyright (c) 2009, Rockwell Automation
sercos® is a registered trademark of sercos® international e.V.
HIPERFACE and HIPERFACE DSL are registered trademarks of Max Stegmann GmbH
PROFINET is a registered trademark of PROFIBUS and PROFINET International (PI)
SIMATIC is a registered trademark of SIEMENS AG
SpeedTec, ytec, itec and htec are registered trademarks of TE Connectivity Ltd.
Windows is a registered trademark of Microsoft Corporation

POWERPAC® K/N Series Stepper Motors

POWERPAC® hybrid stepper motors deliver more power in a smaller package. These rugged NEMA 34 and 42 (90 and 110 mm) motors combine optimal magnetics in a housingless frame with a large diameter rotor and innovative rotor-stator design to produce more torque and smoother microstepping. The K Series incorporates flux-focusing SIGMAX® technology for higher acceleration with 25 percent more torque.

Features

- » Wide range of standard options
- » Affordable co-engineered modifications with a short lead time to meet unique application requirements
- » N3 models, NEMA 34 (90 mm) motors are available in 4 stack lengths with torque ratings from 3.2 to 15.4 N-m (454 to 2,180 oz-in) nominal holding torque.
- » K3 models, NEMA 34 (90 mm) motors are available in 4 stack lengths with torque ratings from 4.08 to 19.7 N-m (578 to 2,790 oz-in) nominal holding torque.
- » N4 models, NEMA 42 (110 mm) motors are available in 3 stack lengths with torque ratings from 8.12 to 30.8 N-m (1,150 to 4,365 oz-in) nominal holding torque.
- » K4 models, NEMA 42 (110 mm) motors are available in 3 stack lengths with torque ratings from 10.4 to 40.3 N-m (1,470 to 5,700 oz-in) nominal holding torque.
- » Extensive selection of shaft configurations, terminations, windings and co-engineered modifications to suit your application needs, time frame and budget
- » Speeds up to 3,000 rpm meet the velocity demands of most high-torque applications
- » Improved torque linearity (above rated current) provides high peak torque to boost acceleration in intermittent-duty applications
- » High torque at moderate speeds to enable a cost-effective alternative to servo motors
- » Low detent torque harmonic provides smoother microstepping performance
- » K Series incorporates SIGMAX® technology for 25% more torque than N Series
- » Runs cooler than comparable steppers to provide longer, more reliable motor life
- » Special rotor design enables high acceleration
- » Rugged, "housingless" square frame means more torque in a smaller package
- » IP65 sealing for splashproof protection
- » Two-phase design is compatible with most drives and provides smoother microstepping and lower power input versus three-phase motors
- » Optional encoder mounting provisions

K/N Series

The K/N Series are larger step motors with the power, rugged construction, and options that make these motors ideal for heavy industrial applications. Options include: IP65, terminal boxes and MS connectors. Enhanced versions provide the maximum performance torque available. This patented technology boosts torque an additional 25% to 40%. Custom motors are available to meet specific application needs including: modified shafts, connectors, lead-screws, and components mounted to the shaft.



K/N Series Benefits

- » More torque to drive heavy loads
- » Smaller drives result in a lower system cost
- » Higher efficiency enables lower operating costs

Size 34 K/N

2 Phase, 1.8° Step Motors. Frame size: 3.4 inch, 87 mm



Series	Construction		Holding Torque (Motor Mounted)		Length	
	Style	Stacks	Bipolar		in	mm
			oz-in	Nm		
K31	Enhanced	1	830	5.9	3.7	94
K32		2	1530	10.8	5.22	133
K33		3	2200	15.6	6.74	171
K34		4	2770	19.6	8.25	210
N31	Un-Enhanced	1	650	4.6	3.7	94
N32		2	1220	8.6	5.22	133
N33		3	1760	12.4	6.74	171
N34		4	2170	15.3	8.25	210

- » Captured heavy duty bearings
- » High voltage insulation system
- » Options:
 - Terminal box
 - MS connectors
 - Rear shaft
 - Encoder
 - Front shaft seal

Size 42 K/N

2 Phase, 1.8° Step Motors. Frame size: 4.3 inch, 110 mm



Series	Construction		Holding Torque (Motor Mounted)		Length	
	Style	Stacks	Bipolar		in	mm
			oz-in	Nm		
K41	Enhanced	1	2090	14.8	3.89	99
K42		2	4000	28.2	5.91	150
K43		3	5650	39.9	7.92	201
N41	Un-Enhanced	1	1630	11.5	3.89	99
N42		2	3140	22.2	5.91	150
N43		3	4340	30.6	7.92	201

- » Captured heavy duty bearings
- » High voltage insulation system
- » Options:
 - Terminal box
 - MS connectors
 - Rear shaft
 - Encoder
 - Front shaft seal

POWERPAC® K/N Series Stepper Motors

General Specifications

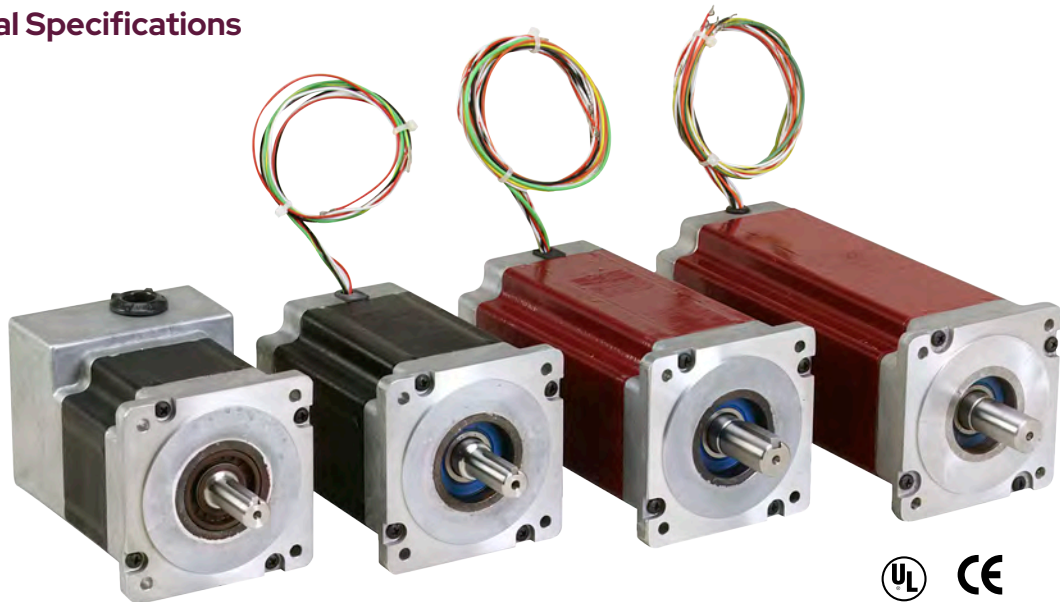

- » NEMA Sizes 34, 42
- » Standard (N) and enhanced (K) using SIGMAX technology
- » Standard NEMA mounting
- » UL, CE compliant
- » Unipolar or Bipolar windings
- » Standard Features: Shaft Flats or Keyways, Rear Shaft, Flying Leads or Motor-Mounted Connectors, Encoder Mounting Provisions, Incremental Encoders, Shaft Seals, Full IP65 Options
- » Co-Engineered Options: Shaft Modifications, Special Windings, Lead Lengths, Connectors

Phases	Bipolar and Unipolar
Full Steps per Revolution	200
Step Angle	1.8°
Step Accuracy (of one full step, no load)	± 1.5 % K3, K4 ± 3 % N3, N4
Operating Temperature	-20°C to +40°C
Insulation Class	Class B, 130°C
Insulation Voltage Rating	340 Vdc
Insulation Resistance	100 Megohms

K/N Series Stepper Motor Model Nomenclature

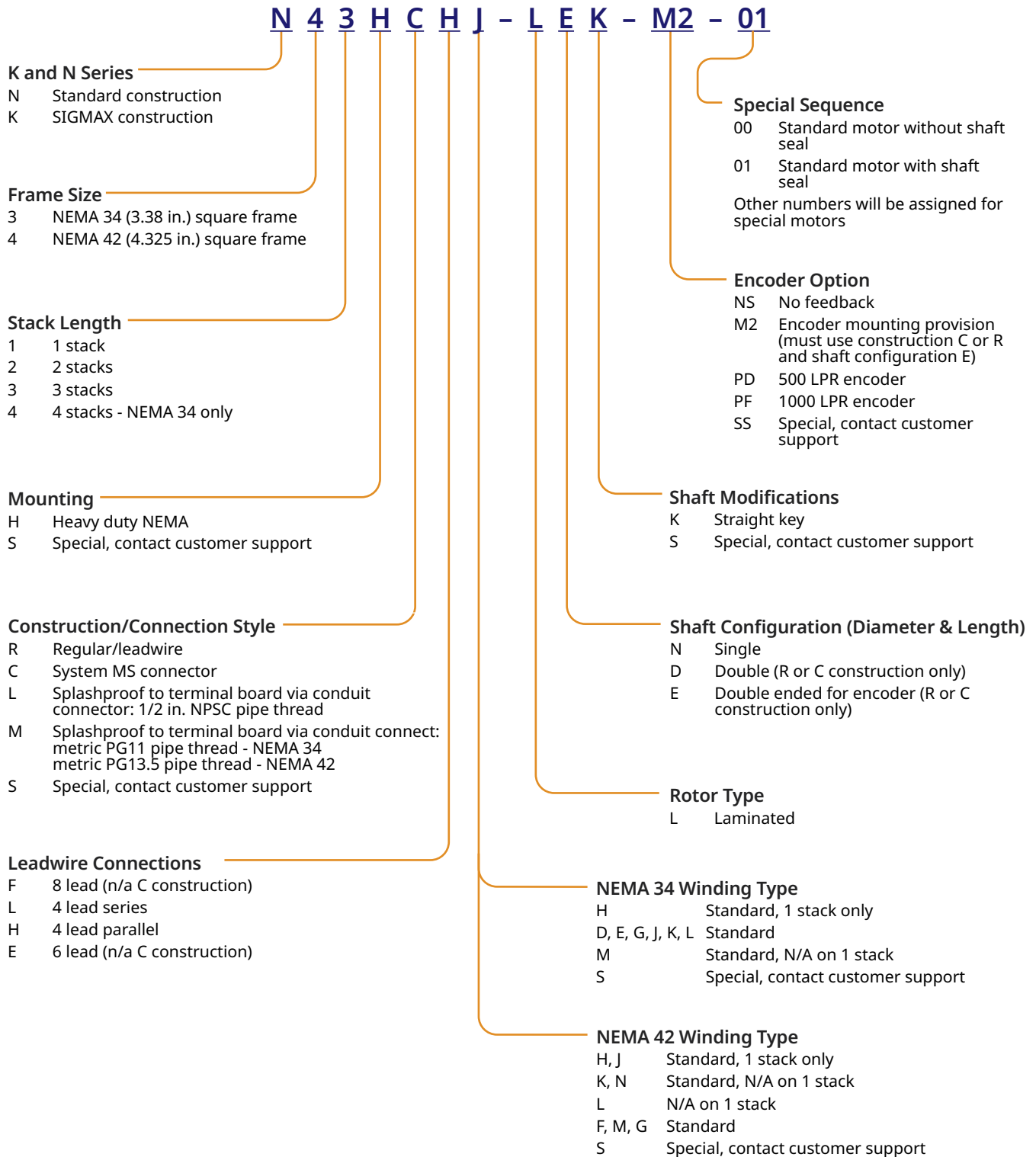

POWERPAC® K/N Series Stepper Motors

K/N Series Stepper Motor F (8 Lead) Connection Information

"F" 8-Lead Configuration

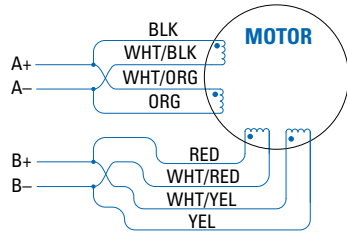

4-Lead Bipolar Connection Parallel

Driver Connection	Lead Color	Terminal Number
A	Black & Wht/Org	1 & 5
\bar{A}	Org & Wht/Blk	3 & 6
B	Red & Wht/Yel	2 & 7
\bar{B}	Yel & Wht/Red	4 & 8

Terminal Board

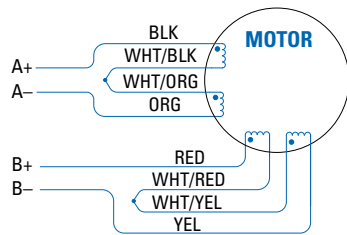
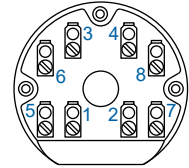

4-Lead Bipolar Connection Series

Driver Connection	Lead Color	Terminal Number
A	Black (Blk)	1
\bar{A}	Orange (Org)	3
B	Red	2
\bar{B}	Yellow (Yel)	4
None	Wht/Blk & Wht/Org	5 & 6
None	Wht/Red & Wht/Yel	7 & 8

Bipolar Full Step Phase Sequence

STEP	A	\bar{A}	B	\bar{B}
1	+	-	-	+
2	-	+	-	+
3	-	+	+	-
4	+	-	+	-
1	+	-	-	+

CCW ↓ ↑ CW

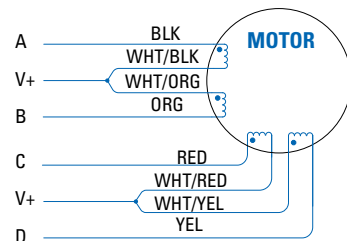

6-Lead Unipolar Connection

Driver Connection	Lead Color	Terminal Number
A	Black (Blk)	1
B	Orange (Org)	3
C	Red	2
D	Yellow (Yel)	4
V+	Wht/Blk & Wht/Org	5 & 6
V+	Wht/Red & Wht/Yel	7 & 8

Unipolar Full Step Phase Sequence

STEP	A	B	C	D
1	GND	0	GND	0
2	0	GND	GND	0
3	0	GND	0	GND
4	GND	0	0	GND
1	GND	0	GND	0

CCW ↓ ↑ CW

K/N Series Stepper Motor E (6 Lead) and H, L (4 Lead) Connection Information

"E" 6-Lead Configuration

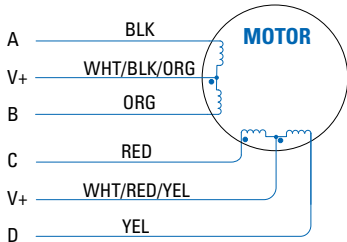

6-Lead Unipolar Connection

Driver Connection	Lead Color	Terminal Number
A	Black (Blk)	1
B	Orange (Org)	3
C	Red	2
D	Yellow (Yel)	4
V+	Wht/Blk/Org	5
V+	Wht/Red/Yel	6

Terminal Board

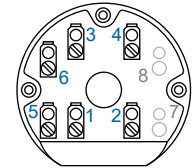

Unipolar Full Step Phase Sequence

STEP	A	B	C	D
1	GND	0	GND	0
2	0	GND	GND	0
3	0	GND	0	GND
4	GND	0	0	GND
1	GND	0	GND	0

CCW ↓ ↑ CW

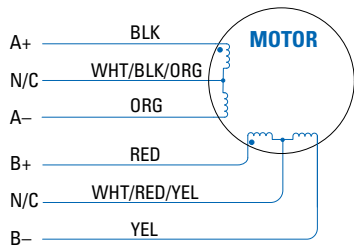

4-Lead Bipolar Series Connection

Driver Connection	Lead Color	Terminal Number
A	Black	1
\bar{A}	Orange	3
B	Red	2
\bar{B}	Yellow	4
N/C	Wht/Blk/Org	5
N/C	Wht/Red/Yel	6
Ground	Green/Yellow	n/a

Bipolar Full Step Phase Sequence

STEP	A	\bar{A}	B	\bar{B}
1	+	-	-	+
2	-	+	-	+
3	-	+	+	-
4	+	-	+	-
1	+	-	-	+

CCW ↓ ↑ CW

"H" "L" 4-Lead Configuration

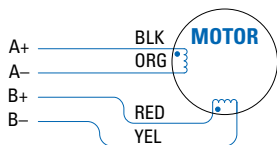

4-Lead Bipolar Connection

Driver Connection	Lead Color	Terminal Number	MS Connector Pinout
A	Black	1	A
\bar{A}	Orange	3	B
B	Red	2	C
\bar{B}	Yellow	4	D
Ground	Green/Yellow	n/a	E

Terminal Board

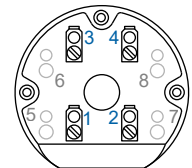

MS Connector
MS3102R14S-5P

Mating Plug Type
MS3106F14S-5S

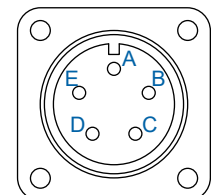

K3 / N3 Outline Drawings

Splashproof Construction / Terminal Board Connections

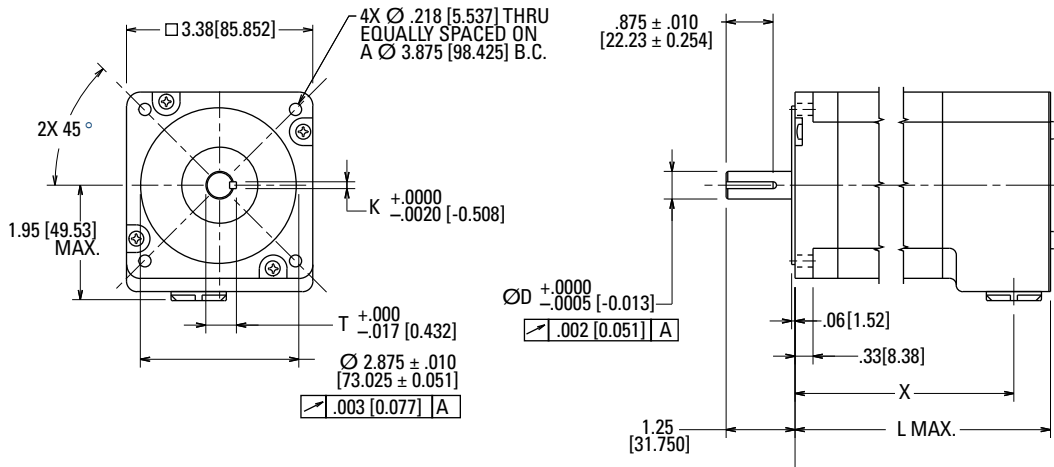

Dimensions in inches [mm]

Model	"D"	"K"	"T"	"X"	"L" MAX
31HL	0.5000 (12.700)	0.1250 (3.175)	0.555 (14.097)	3.70 (93.98)	4.44 (112.78)
32HL				5.22 (132.59)	5.96 (151.38)
33HL	0.6250 (15.875)	0.1875 (4.763)	0.705 (17.907)	6.74 (171.20)	7.48 (189.99)
34HL				8.25 (209.55)	8.99 (228.35)

K3 / N3 Series Stepper Motors

K3 / N3 Outline Drawings

Splashproof Construction / MS Connector(s)

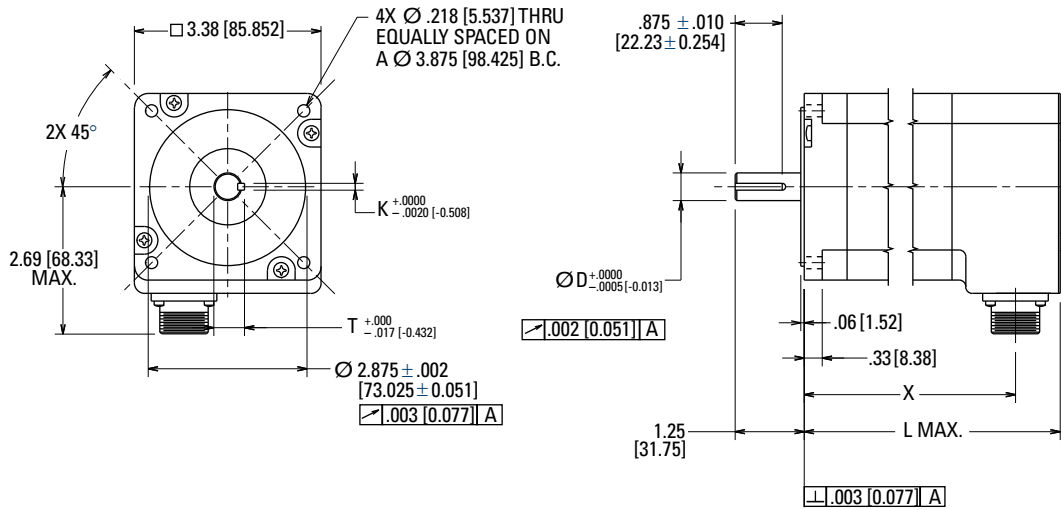

Dimensions in inches [mm]

Model	"D"	"K"	"T"	"X"	"L" MAX
31HC	0.5000	0.1250	0.555	3.56 (90.42)	4.44 (112.78)
32HC	(12.700)	(3.175)	(14.097)	5.07 (128.78)	5.96 (151.38)
33HC	0.6250	0.1875	0.705	6.59 (165.10)	7.48 (189.99)
34HC	(15.875)	(4.763)	(17.907)	8.11 (205.99)	8.99 (228.35)

Encoder Mounting Option

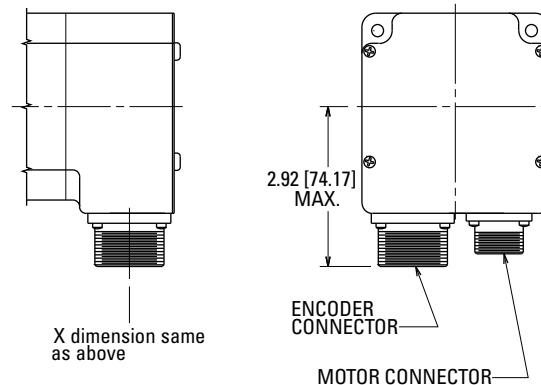

Notes

N - Motor Series
4 - Frame Size
2 - Stack Length
H - Mounting
R - Construction
L - Lead Connection
G - Winding Type
-
L - Rotor Type
N - Shaft Cfg.
N - Shaft Mod.
-
NS - Encoder Opt.
-
00 - Customization

0.125 inch divisions

K3 / N3 Series Stepper Motors

K3 / N3 1 Stack Performance Data

	Motor Model Number	Config.			Holding Torque (2 phases on) oz-in (Nm) +/-10%	Rated Current/Phase Amps DC	Phase Resistance Ohms +/-10%	Phase Inductance mH Typical	Thermal Resistance Mounted °C/Watt	Rotor Inertia oz-in-s ² (kg-m ² x 10 ⁻³)	Weight lb (kg)	Shaft Loading	
		Parallel	Series	Unipolar								Radial Force lb (N)	Axial Force lb (N)
1 Stack	N31xxHL-L	•			650 (4.59)	8.6	0.18	1.4	2.7	0.0202 (0.14)	5.0 (2.3)	65 (289)	305 (1360)
	N31xxLL-L		•			4.3	0.72						
	N31xxHK-L	•			665 (4.69)	6.6	0.29	2.6					
	N31xxLK-L		•			3.3	1.16	10.3					
	N31xxHJ-L	•			645 (4.55)	5.5	0.42	3.5					
	N31xxLJ-L		•			2.7	1.69	14					
	N31xxHH-L	•			635 (4.48)	2.8	1.55	12.5					
	N31xxLH-L		•			1.4	6.21	50.1					
	N31xxHG-L	•			641 (4.52)	1.73	4.06	34.5					
	N31xxLG-L		•			0.86	16.2	138					
	N31xxEL-L			•	460 (3.25)	6.1	0.36	1.4					
	N31xxEK-L			•	470 (3.32)	4.7	0.58	2.6					
	N31xxEJ-L			•	455 (3.21)	3.9	0.84	3.5					
	N31xxEH-L			•	450 (3.18)	2.0	3.10	12.5					
N31xxEG-L			•	453 (3.20)	1.22	8.12	34.5						
Enhanced 1 Stack	K31xxHL-L	•			830 (5.86)	8.6	0.18	1.2	2.7	0.0202 (0.14)	5.0 (2.3)	65 (289)	305 (1360)
	K31xxLL-L		•			4.3	0.72	4.7					
	K31xxHK-L	•			845 (5.96)	6.6	0.29	2.1					
	K31xxLK-L		•			3.3	1.16	8.3					
	K31xxHJ-L	•			820 (5.79)	5.5	0.42	2.8					
	K31xxLJ-L		•			2.7	1.69	11.4					
	K31xxHH-L	•			805 (5.68)	2.8	1.55	10.2					
	K31xxLH-L		•			1.4	6.21	40.7					
	K31xxHG-L	•			816 (5.76)	1.73	4.06	28.1					
	K31xxLG-L		•			0.86	16.2	112					
	K31xxEL-L			•	590 (4.16)	6.1	0.36	1.2					
	K31xxEK-L			•	600 (4.23)	4.7	0.58	2.1					
	K31xxEJ-L			•	580 (4.09)	3.9	0.84	2.8					
	K31xxEH-L			•	570 (4.03)	2.0	3.10	10.2					
K31xxEG-L			•	577 (4.08)	1.22	8.12	28.1						

K3 / N3 2 Stack Performance Data

	Motor Model Number	Config.			Holding Torque (2 phases on) oz-in (Nm) +/-10%	Rated Current/Phase Amps DC	Phase Resistance Ohms +/-10%	Phase Inductance mH Typical	Thermal Resistance Mounted °C/Watt	Rotor Inertia oz-in-s ² (kg-m ² x 10 ⁻³)	Weight lb (kg)	Shaft Loading	
		Parallel	Series	Unipolar								Radial Force lb (N)	Axial Force lb (N)
2 Stack	N32xxHD-L	•			1195 (8.45)	3.2	1.57	16.5	2.0	0.038 (0.27)	8.4 (3.8)	65 (289)	305 (1360)
	N32xxLD-L		•			1.6	6.30	66.1					
	N32xxHM-L	•			1215 (8.58)	10	0.18	1.8					
	N32xxLM-L		•			5.0	0.70	7.0					
	N32xxHL-L	•			1200 (8.47)	8.1	0.26	2.6					
	N32xxLL-L		•			4.1	1.03	10.3					
	N32xxHK-L	•			1245 (8.79)	6.1	0.45	5.1					
	N32xxLK-L		•			3.0	1.80	20.6					
	N32xxHJ-L	•			1195 (8.43)	5.1	0.63	6.5					
	N32xxLJ-L		•			2.5	2.53	26					
	N32xxHG-L	•			1240 (8.76)	1.91	4.41	51.6					
	N32xxLG-L		•			0.95	17.6	206					
	N32xxED-L			•	845 (5.97)	2.3	3.15	16.5					
	N32xxEM-L			•	860 (6.07)	7.1	0.35	1.8					
	N32xxEL-L			•	850 (6.00)	5.8	0.52	2.6					
	N32xxEK-L			•	885 (6.25)	4.3	0.90	5.1					
N32xxEJ-L			•	845 (5.96)	3.5	1.27	6.5						
N32xxEG-L			•	887 (6.19)	1.35	8.82	51.6						
Enhanced 2 Stack	K32xxHD-L	•			1510 (10.7)	3.2	1.57	13.0	2.0	0.038 (0.27)	8.4 (3.8)	65 (289)	305 (1360)
	K32xxLD-L		•			1.6	6.30	51.9					
	K32xxHM-L	•			1535 (10.8)	10	0.18	1.4					
	K32xxLM-L		•			5.0	0.70	5.5					
	K32xxHL-L	•			1515 (10.7)	8.1	0.26	2.0					
	K32xxLL-L		•			4.1	1.03	8.1					
	K32xxHK-L	•			1580 (11.2)	6.1	0.45	4.0					
	K32xxLK-L		•			3.0	1.8	16.2					
	K32xxHJ-L	•			1510 (10.7)	5.1	0.63	5.1					
	K32xxLJ-L		•			2.5	2.53	20.5					
	K32xxHG-L	•			1570 (11.1)	1.91	4.41	51.6					
	K32xxLG-L		•			0.95	17.6	162					
	K32xxED-L			•	1065 (7.53)	2.3	3.15	13.0					
	K32xxEM-L			•	1085 (7.66)	7.1	0.35	1.4					
	K32xxEL-L			•	1070 (7.55)	5.8	0.52	2.0					
	K32xxEK-L			•	1120 (7.90)	4.3	0.90	4.0					
	K32xxEJ-L			•	1065 (7.52)	3.5	1.27	5.1					
	K32xxEG-L			•	1110 (7.85)	1.35	8.82	40.5					

K3 / N3 Series Stepper Motors

K3 / N3 3 Stack Performance Data

Motor Model Number	Config.			Holding Torque (2 phases on) oz-in (Nm) +/-10%	Rated Current/Phase Amps DC	Phase Resistance Ohms +/-10%	Phase Inductance mH Typical	Thermal Resistance Mounted °C/Watt	Rotor Inertia oz-in-s ² (kg-m ² x 10 ⁻³)	Weight lb (kg)	Shaft Loading	
	Parallel	Series	Unipolar								Radial Force lb (N)	Axial Force lb (N)
3 Stack	N33xxHE-L	•		1700 (12.0)	4.0	1.27	13.6	1.6	0.0567 (0.40)	11.9 (5.39)	110 (489)	305 (1360)
	N33xxLE-L		•		2.0	5.06	54.5					
	N33xxHM-L	•		1715 (12.1)	9.9	0.22	2.3					
	N33xxLM-L		•		5.0	0.87	9.0					
	N33xxHL-L	•		1845 (13.0)	9.0	0.26	3.4					
	N33xxLL-L		•		4.5	1.06	13.6					
	N33xxHK-L	•		1755 (12.4)	6.1	0.56	6.4					
	N33xxLK-L		•		3.0	2.23	25.8					
	N33xxHJ-L	•		1710 (12.1)	5.0	0.83	9.0					
	N33xxLJ-L		•		2.5	3.31	36					
	N33xxHG-L	•		1710 (12.1)	2.50	3.25	36					
	N33xxLG-L		•		1.24	13.1	144					
	N33xxEE-L		•	1200 (8.47)	2.8	2.53	13.6					
	N33xxEM-L		•	1215 (8.58)	7.0	0.44	2.3					
	N33xxEL-L		•	1305 (9.21)	6.3	0.53	3.4					
	N33xxEK-L		•	1240 (8.75)	4.3	1.12	6.4					
N33xxEJ-L		•	1210 (8.54)	3.5	1.65	9.0						
N33xxEG-L		•	1210 (8.55)	1.75	6.51	36						
Enhanced 3 Stack	K33xxHE-L	•		2125 (15.0)	4.0	1.27	10.6	1.6	0.0567 (0.40)	11.9 (5.39)	110 (489)	305 (1360)
	K33xxLE-L		•		2.0	5.06	42.2					
	K33xxHM-L	•		2150 (15.2)	9.9	0.22	1.7					
	K33xxLM-L		•		5.0	0.87	7.0					
	K33xxHL-L	•		2340 (16.5)	9.0	0.26	2.6					
	K33xxLL-L		•		4.5	1.06	10.6					
	K33xxHK-L	•		2205 (15.6)	6.1	0.56	5.0					
	K33xxLK-L		•		3.0	2.23	19.9					
	K33xxHJ-L	•		2145 (15.1)	5.0	0.83	7.0					
	K33xxLJ-L		•		2.5	3.31	27.9					
	K33xxHG-L	•		2145 (15.1)	2.5	3.25	27.9					
	K33xxLG-L		•		1.24	13.1	111					
	K33xxEE-L		•	1505 (10.6)	2.8	2.53	10.6					
	K33xxEM-L		•	1520 (10.7)	7.0	0.44	1.7					
	K33xxEL-L		•	1655 (11.7)	6.3	0.53	2.6					
	K33xxEK-L		•	1560 (11.0)	4.3	1.12	5.0					
K33xxEJ-L		•	1515 (10.7)	3.5	1.65	7.0						
K33xxEG-L		•	1515 (10.7)	1.75	6.51	27.9						

K3 / N3 4 Stack Performance Data

	Motor Model Number	Config.			Holding Torque (2 phases on)	Rated Current/Phase	Phase Resistance	Phase Inductance	Thermal Resistance	Rotor Inertia	Weight	Shaft Loading	
		Parallel	Series	Unipolar								Radial Force	Axial Force
					oz-in (Nm) +/-10%	Amps DC	Ohms +/-10%	mH Typical	Mounted °C/Watt	oz-in-s ² (kg-m ² x 10 ⁻³)	lb (kg)		
4 Stack	N34xxHM-L	•			2140 (15.1)	11.3	0.20	2.6	1.3	0.075 (0.53)	15.1 (6.85)	110 (489)	305 (1360)
	N34xxLM-L		•			5.6	0.82	10.6					
	N34xxHL-L	•			2180 (15.4)	8.7	0.33	4.7					
	N34xxLL-L		•			4.4	1.32	18.8					
	N34xxHK-L	•			2035 (14.4)	6.0	0.67	8.1					
	N34xxLK-L		•			3.0	2.69	32.4					
	N34xxHJ-L	•			2170 (15.3)	5.5	0.80	11.5					
	N34xxLJ-L		•			2.8	3.19	45.9					
	N34xxHG-L	•			2170 (15.3)	3.5	2.0	29.4					
	N34xxLG-L		•			1.7	8.0	117					
	N34xxEM-L			•	1510 (10.7)	8.0	0.41	2.6					
	N34xxEL-L			•	1545 (10.9)	6.2	0.66	4.7					
	N34xxEK-L			•	1440 (10.2)	4.3	1.35	8.1					
N34xxEJ-L			•	1535 (10.8)	3.9	1.6	11.5						
N34xxEG-L			•	1535 (10.8)	2.5	4.0	29.4						
Enhanced 4 Stack	K34xxHM-L	•			2725 (19.2)	11.3	0.20	2.0	1.3	0.075 (0.53)	15.5 (6.85)	110 (489)	305 (1360)
	K34xxLM-L		•			5.6	0.82	8.2					
	K34xxHL-L	•			2790 (19.7)	8.7	0.33	3.6					
	K34xxLL-L		•			4.4	1.32	14.5					
	K34xxHK-L	•			2580 (18.2)	6.0	0.67	6.3					
	K34xxLK-L		•			3.0	2.69	25.1					
	K34xxHJ-L	•			2770 (19.6)	5.5	0.80	8.9					
	K34xxLJ-L		•			2.8	3.19	35.5					
	K34xxHG-L	•			2780 (19.6)	3.5	2.0	22.7					
	K34xxLG-L		•			1.7	8.0	91					
	K34xxEM-L			•	1930 (13.6)	8.0	0.41	2.0					
	K34xxEL-L			•	1975 (13.9)	6.2	0.66	3.6					
	K34xxEK-L			•	1825 (12.9)	4.3	1.35	6.3					
	K34xxEJ-L			•	1960 (13.8)	3.9	1.6	8.9					
	K34xxEG-L			•	1965 (13.9)	2.5	4.0	22.7					

K3 / N3 Series Stepper Motors

K3/N3 Performance Curves

N31xxHJ-L w/ P70530

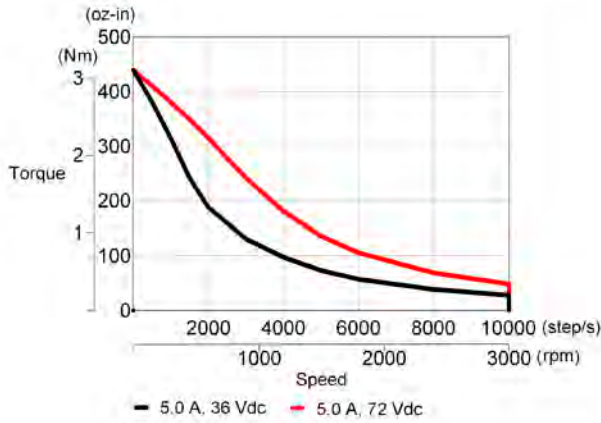

K31xxHJ-L w/ P70530

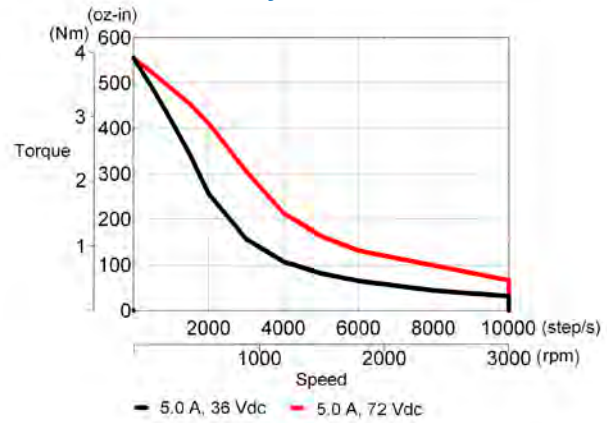

N32xxHJ-L w/ P70530

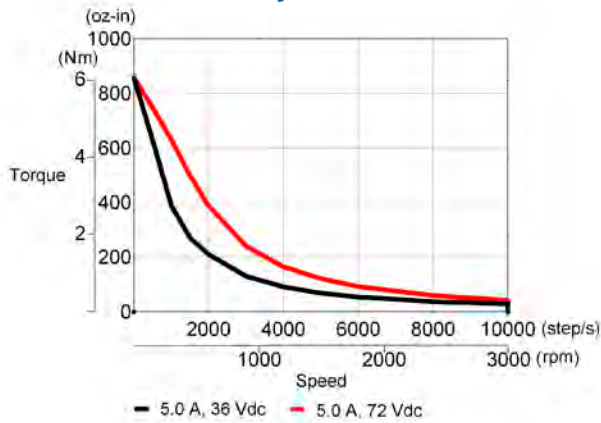

K32xxHJ-L w/ P70530

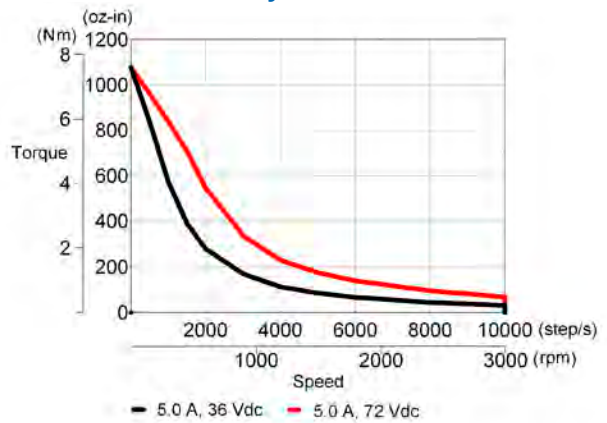

N33xxHJ-L w/ P70530

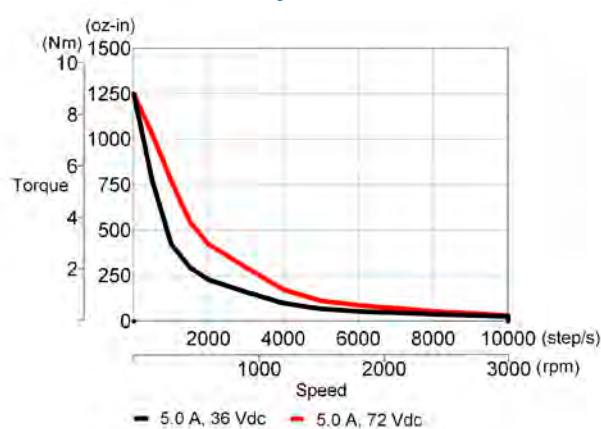

K33xxHJ-L w/ P70530

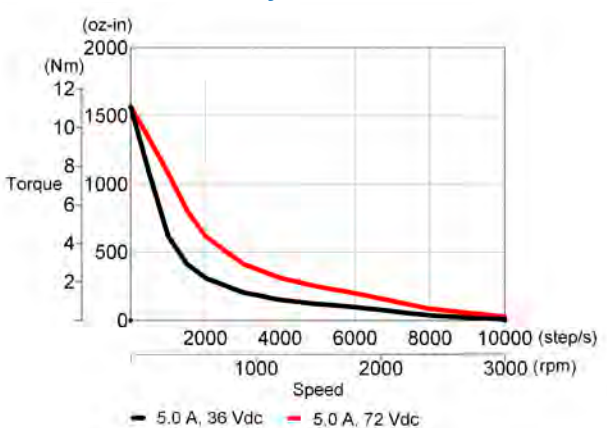

K3/N3 Performance Curves

N34xxHJ-L w/ P70530

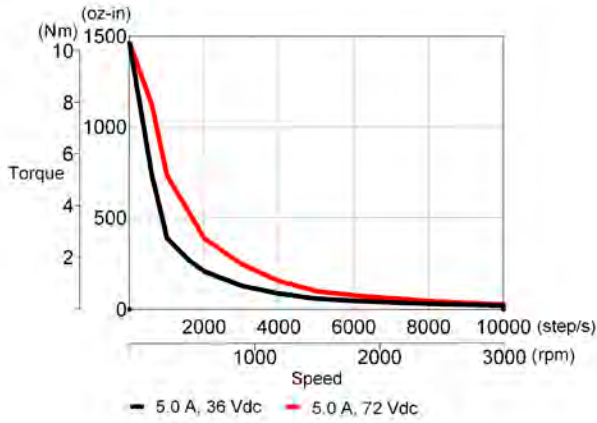

K34xxHJ-L w/ P70530

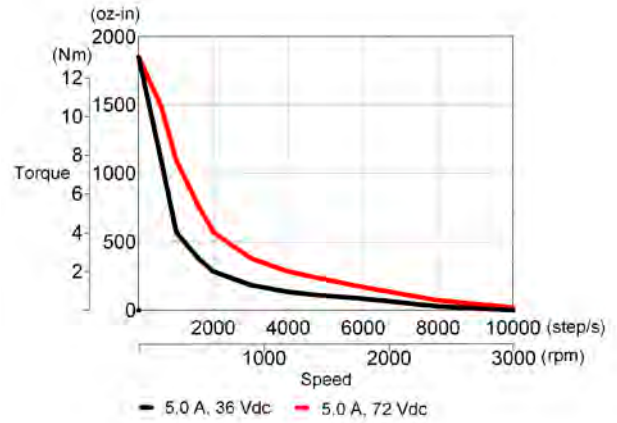

N31xxxH-L w/ P6000

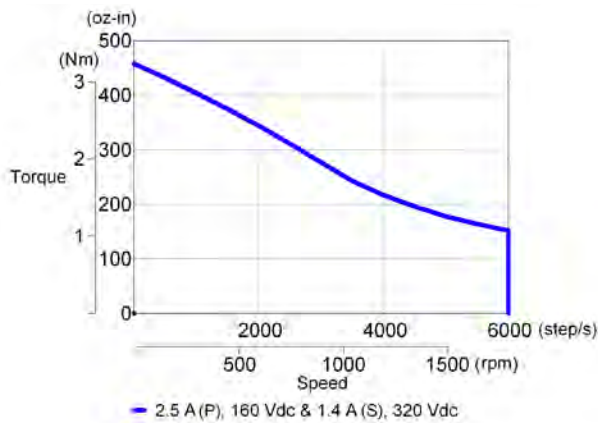

K31xxxH-L w/ P6000

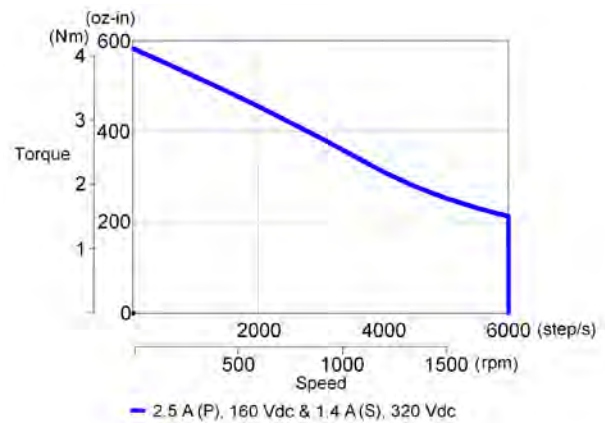

N31xxLG-L w/ P70360

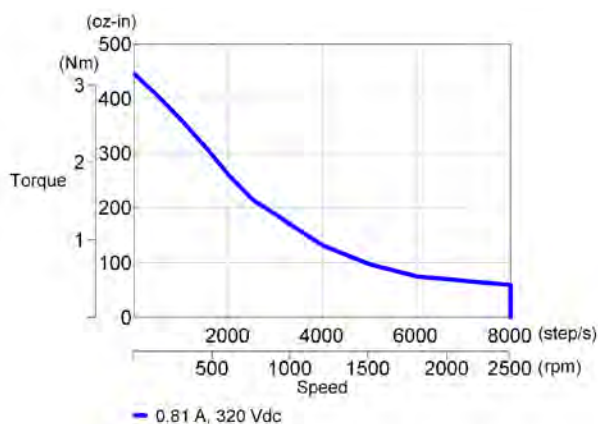

K31xxLG-L (P) w/ P70360

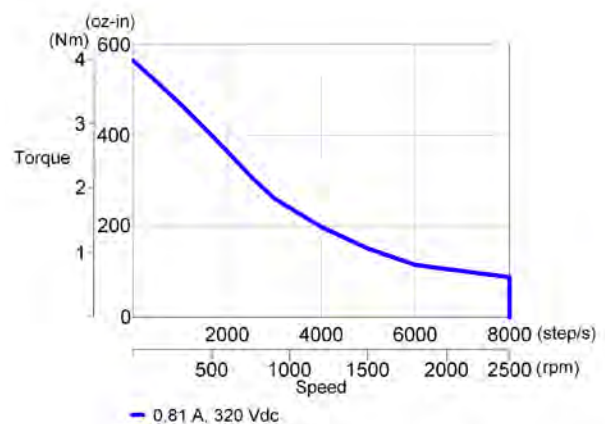

K3 / N3 Series Stepper Motors

K3/N3 Performance Curves

N32xxxD-L w/ P6000

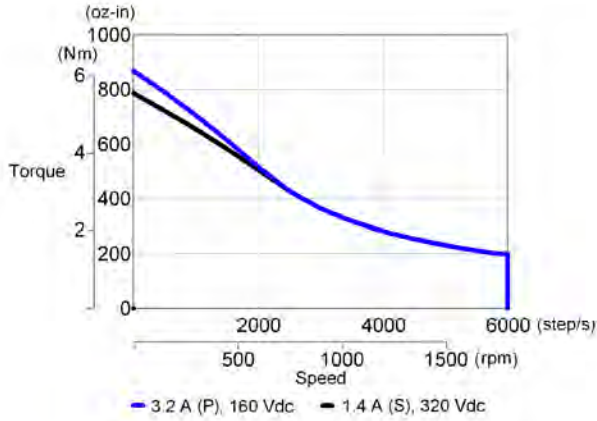

K32xxxD-L w/ P6000

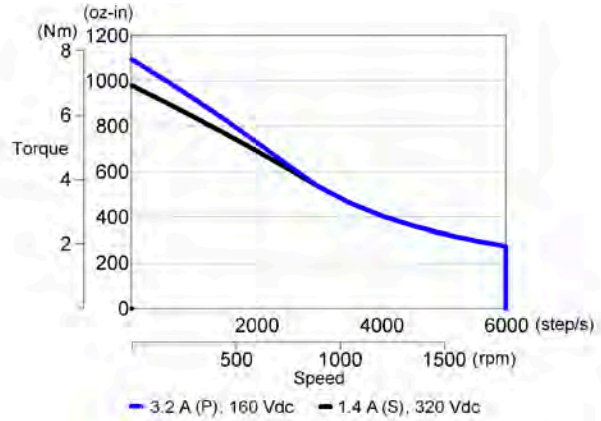

N32xxLG-L w/ P70360

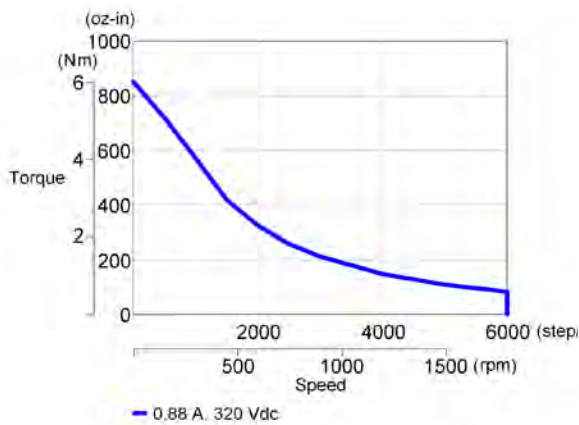

K32xxLG-L w/ P70360

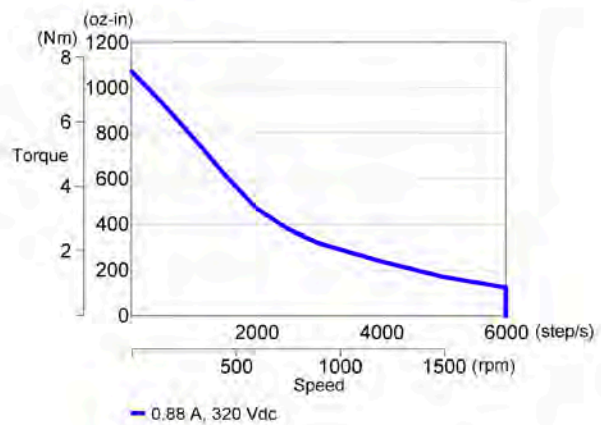

N33xxxE-L w/ P6000

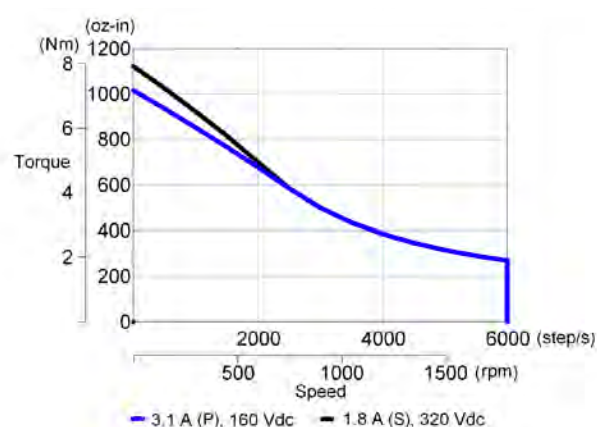

K33xxxE-L w/ P6000

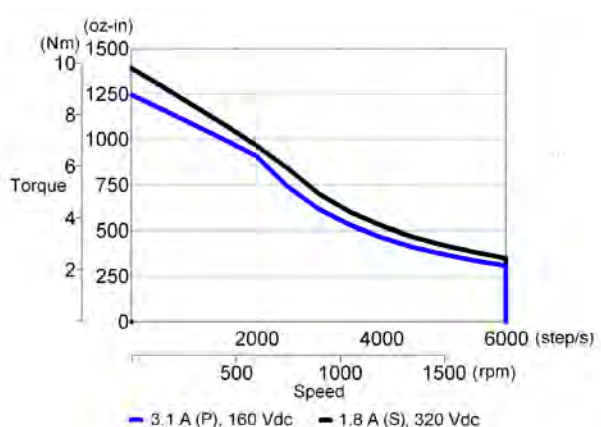

K3/N3 Performance Curves

N33xxLG-L w/ P70360

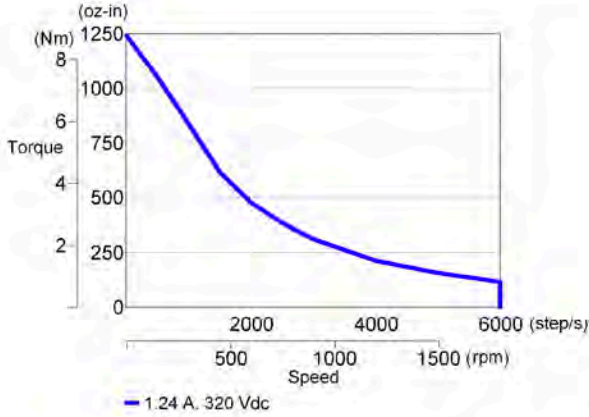

K32xxLG-L w/ P70360

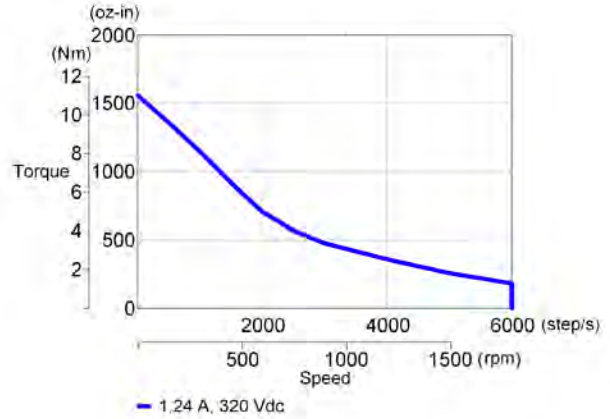

N34xxLG-L w/ P70360

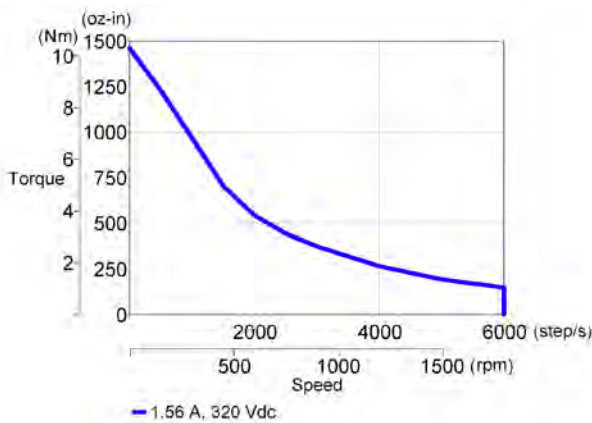

K34xxLG-L w/ P70360

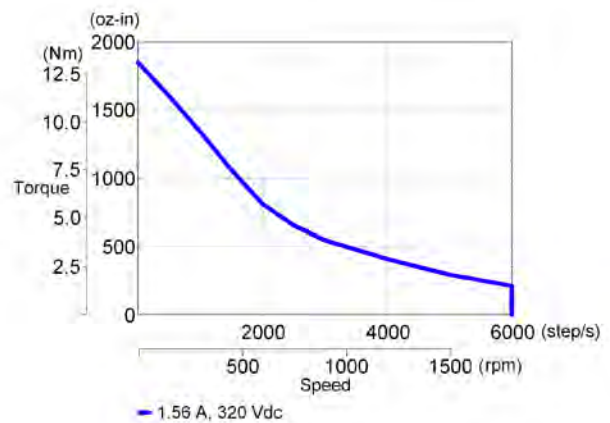

K4 / N4 Series Stepper Motors

K4 / N4 Outline Drawings

Regular Leadwire Hookup

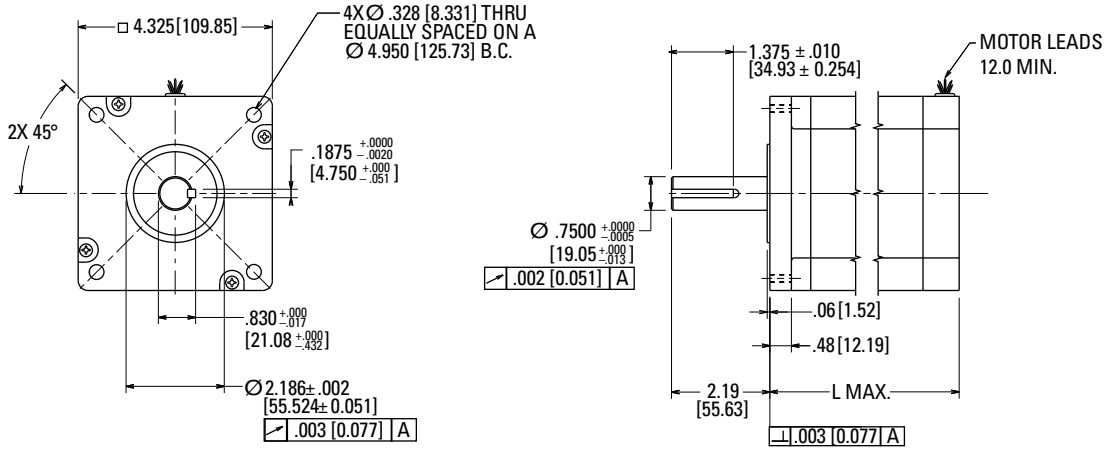

Model	"L" MAX
41HR	3.89 (98.81)
42HR	5.91 (150.11)
43HR	7.92 (201.17)

Dimensions in inches [mm]

Splashproof Construction / Terminal Board Connections

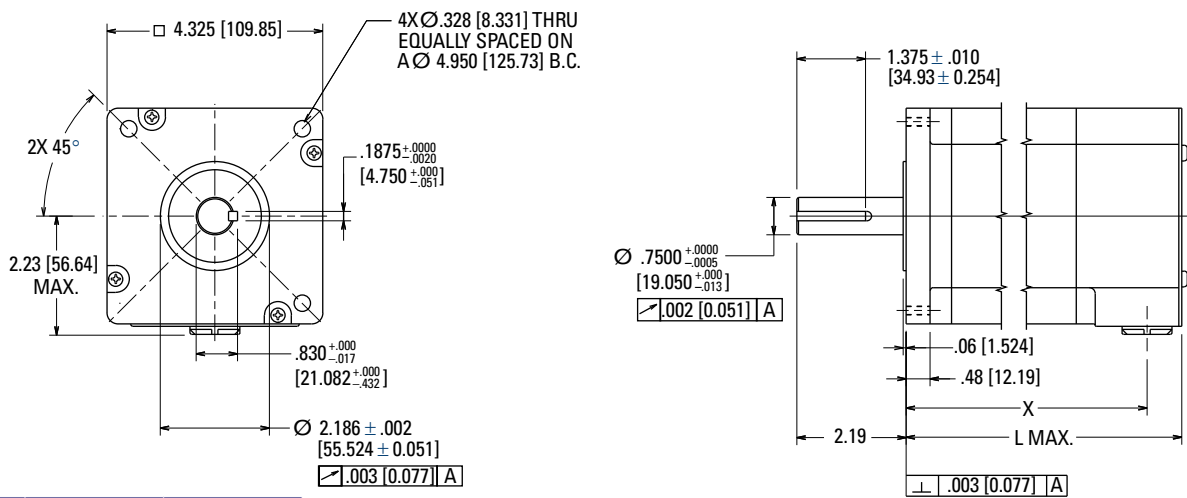

Model	"X"	"L" MAX
41HL	4.46 (113.28)	5.20 (132.08)
42HL	6.48 (164.59)	7.22 (183.39)
43HL	8.49 (215.65)	9.23 (234.44)

Dimensions in inches [mm]

K4 / N4 Outline Drawings

Splashproof Construction / MS Connector(s)

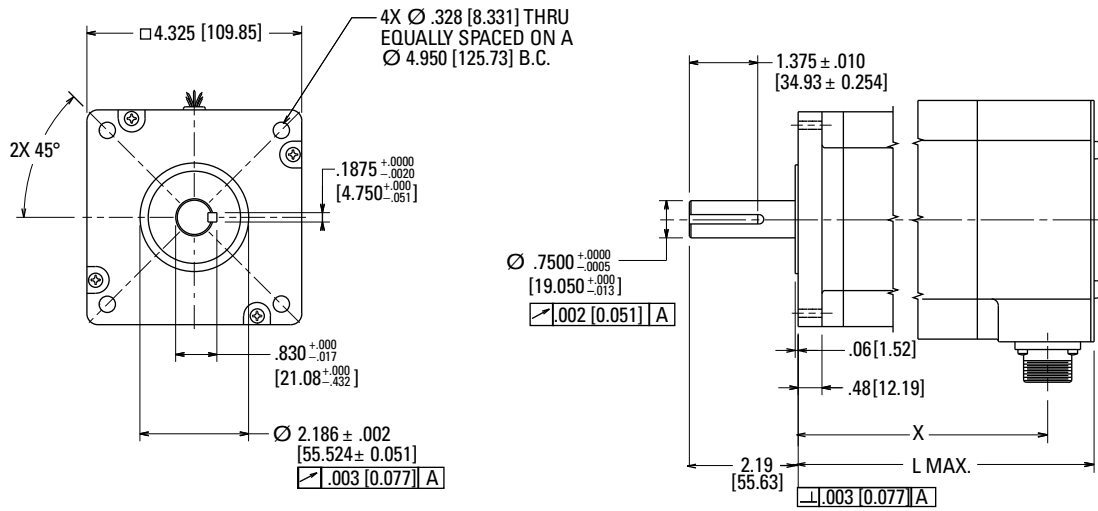

Model	"X"	"L" MAX
41HC	4.32 (109.73)	5.20 (132.08)
42HC	6.33 (160.78)	7.22 (183.39)
43HC	8.35 (212.09)	9.23 (234.44)

Dimensions in inches [mm]

K4 / N4 Series Stepper Motors

K4 / N4 1 Stack Performance Data

	Motor Model Number	Config.			Holding Torque (2 phases on) oz-in (Nm) +/-10%	Rated Current/Phase Amps DC	Phase Resistance Ohms +/-10%	Phase Inductance mH Typical	Thermal Resistance Mounted °C/Watt	Rotor Inertia oz-in-s ² (kg-m ² x 10 ⁻³)	Weight lb (kg)	Shaft Loading	
		Parallel	Series	Unipolar								Radial Force lb (N)	Axial Force lb (N)
1 Stack	N41xxHF-L	•			1675 (11.8)	5.2	0.64	12.2	1.9	0.0783 (0.55)	11 (4.98)	125 (556)	404 (1800)
	N41xxLF-L		•			2.6	2.56	48.9					
	N41xxHM-L	•			1655 (11.7)	10.7	0.16	2.8					
	N41xxLM-L		•			5.3	0.63	11.1					
	N41xxHL-L	•			1625 (11.5)	8.7	0.23	3.9					
	N41xxLL-L		•			4.4	0.93	15.8					
	N41xxHJ-L	•			1630 (11.5)	5.5	0.58	10.1					
	N41xxLJ-L		•			2.7	2.33	40.4					
	N41xxHG-L	•			1630 (11.5)	3.5	1.45	25.1					
	N41xxLG-L		•			1.73	5.76	100					
	N41xxEF-L			•	1185 (8.37)	3.7	1.28	12.2					
	N41xxEM-L			•	1170 (8.26)	7.5	0.23	2.8					
	N41xxEL-L			•	1150 (8.12)	6.2	2.33	3.9					
	N41xxEJ-L			•	1150 (8.12)	3.9	1.16	10.1					
N41xxEG-L			•	1150 (8.12)	2.4	2.89	25.1						
Enhanced 1 Stack	K41xxHF-L	•			2170 (15.3)	5.2	0.64	9.5	1.9	0.0783 (0.55)	11 (4.98)	125 (556)	404 (1800)
	K41xxLF-L		•			2.6	2.56	38					
	K41xxHM-L	•			2135 (15.1)	10.7	0.16	2.2					
	K41xxLM-L		•			5.3	0.63	8.7					
	K41xxHL-L	•			2090 (14.8)	8.7	0.23	3.1					
	K41xxLL-L		•			4.4	0.93	12.3					
	K41xxHJ-L	•			2095 (14.8)	5.5	0.58	7.8					
	K41xxLJ-L		•			2.7	2.33	31.4					
	K41xxHG-L	•			2095 (14.8)	3.5	1.45	19.5					
	K41xxLG-L		•			1.73	5.80	77.9					
	K41xxEF-L			•	1535 (10.8)	3.7	1.28	9.5					
	K41xxEM-L			•	1510 (10.7)	7.5	0.31	2.2					
	K41xxEL-L			•	1480 (10.5)	6.2	0.47	3.1					
	K41xxEJ-L			•	1480 (10.5)	3.9	1.16	7.8					
K41xxEG-L			•	1480 (10.5)	2.4	2.89	25.1						

K4 / N4 2 Stack Performance Data

Motor Model Number	Config.			Holding Torque (2 phases on) oz-in (Nm) +/-10%	Rated Current/Phase Amps DC	Phase Resistance Ohms +/-10%	Phase Inductance mH Typical	Thermal Resistance Mounted °C/Watt	Rotor Inertia oz-in-s ² (kg-m ² x 10 ⁻³)	Weight lb (kg)	Shaft Loading	
	Parallel	Series	Unipolar								Radial Force lb (N)	Axial Force lb (N)
2 Stack	N42xxHF-L	•		2925 (20.6)	5.5	0.81	14.4	1.3	0.155 (1.09)	18.4 (8.34)	110 (489)	404 (1800)
	N42xxLF-L		•	2923 (20.6)	2.7	3.2	57.7					
	N42xxHN-L	•		3130 (22.1)	15.8	0.10	2.1					
	N42xxLN-L		•		7.9	0.41	8.4					
	N42xxHM-L	•		3145 (22.2)	9.9	0.25	5.5					
	N42xxLM-L		•		4.9	1.02	22					
	N42xxHL-L	•		3085 (21.8)	8.1	0.38	7.8					
	N42xxLL-L		•		4.0	1.51	31.2					
	N42xxHK-L	•		3105 (21.9)	6.4	0.60	12.8					
	N42xxLK-L		•		3.2	2.41	51.1					
	N42xxHG-L	•		2315 (22.7)	4.8	1.07	25.3					
	N42xxLG-L		•		2.4	4.27	101					
	N42xxEF-L		•	2065 (14.6)	3.9	1.62	14.4					
	N42xxEN-L		•	2215 (15.6)	11.2	0.21	2.1					
	N42xxEM-L		•	2225 (15.7)	7.0	0.51	5.5					
	N42xxEL-L		•	2185 (15.4)	5.7	0.75	7.8					
	N42xxEK-L		•	2200 (15.5)	4.5	1.2	12.8					
N42xxEG-L		•	2920 (20.6)	3.4	2.14	19.4						
Enhanced 2 Stack	K42xxHF-L	•		3700 (26.1)	5.5	0.81	11.1	1.2	0.155 (1.09)	18.4 (8.34)	110 (489)	404 (1800)
	K42xxLF-L		•		2.7	3.23	44.2					
	K42xxHN-L	•		4000 (28.2)	15.8	0.10	1.6					
	K42xxLN-L		•		7.9	0.41	6.5					
	K42xxHM-L	•		4025 (28.4)	9.9	0.25	4.2					
	K42xxLM-L		•		4.9	1.02	16.9					
	K42xxHL-L	•		3935 (27.8)	8.1	0.38	6.0					
	K42xxLL-L		•		4.0	1.51	23.9					
	K42xxHK-L	•		3965 (28.0)	6.4	0.60	9.8					
	K42xxLK-L		•		3.2	2.41	39.2					
	K42xxHG-L	•		4130 (29.1)	4.8	1.07	19.4					
	K42xxLG-L		•		2.4	4.27	77.5					
	K42xxEF-L		•	2615 (18.5)	3.9	1.62	11.1					
	K42xxEN-L		•	2830 (20.0)	11.2	0.21	1.6					
	K42xxEM-L		•	2845 (20.1)	7.0	0.51	4.2					
	K42xxEL-L		•	2785 (19.7)	5.7	0.75	6.0					
	K42xxEK-L		•	2805 (19.8)	4.5	1.2	9.8					
K42xxEG-L		•	2920 (20.6)	3.4	2.14	19.4						

K4 / N4 Series Stepper Motors

K4 / N4 3 Stack Performance Data

	Motor Model Number	Config.			Holding Torque (2 phases on) oz-in (Nm) +/-10%	Rated Current/Phase Amps DC	Phase Resistance Ohms +/-10%	Phase Inductance mH Typical	Thermal Resistance Mounted °C/Watt	Rotor Inertia oz-in-s ² (kg-m ² x 10 ⁻³)	Weight lb (kg)	Shaft Loading	
		Parallel	Series	Unipolar								Radial Force lb (N)	Axial Force lb (N)
Enhanced 2 Stack	K42xxHF-L	•			3700 (26.1)	5.5	0.81	11.1	1.2	0.155 (1.09)	18.4 (8.34)	110 (489)	404 (1800)
	K42xxLF-L		•			2.7	3.23	44.2					
	K42xxHN-L	•			4000 (28.2)	15.8	0.10	1.6					
	K42xxLN-L		•			7.9	0.41	6.5					
	K42xxHM-L	•			4025 (28.4)	9.9	0.25	4.2					
	K42xxLM-L		•			4.9	1.02	16.9					
	K42xxHL-L	•			3935 (27.8)	8.1	0.38	6.0					
	K42xxLL-L		•			4.0	1.51	23.9					
	K42xxHK-L	•			3965 (28.0)	6.4	0.60	9.8					
	K42xxLK-L		•			3.2	2.41	39.2					
	K42xxHG-L	•			4130 (29.1)	4.8	1.07	19.4					
	K42xxLG-L		•			2.4	4.27	77.5					
	K42xxEF-L			•	2615 (18.5)	3.9	1.62	11.1					
	K42xxEN-L			•	2830 (20.0)	11.2	0.21	1.6					
	K42xxEM-L			•	2845 (20.1)	7.0	0.51	4.2					
	K42xxEL-L			•	2785 (19.7)	5.7	0.75	6.0					
K42xxEK-L			•	2805 (19.8)	4.5	1.2	9.8						
K42xxEG-L			•	2920 (20.6)	3.4	2.14	19.4						
3 Stack	N43xxHN-L	•			4365 (30.8)	15.4	0.14	3.2	1.0	0.229 (1.62)	25.7 (11.6)	110 (489)	404 (1800)
	N43xxLN-L		•			7.7	0.55	13					
	N43xxHM-L	•			4320 (30.5)	9.9	0.33	7.7					
	N43xxLM-L		•			4.9	1.32	30.7					
	N43xxHL-L	•			4250 (30.0)	8.0	0.50	11					
	N43xxLL-L		•			4.0	1.98	44.2					
	N43xxHK-L	•			4340 (30.6)	6.2	0.82	19.6					
	N43xxLK-L		•			3.1	3.29	78.5					
	N43xxEN-L			•	3090 (21.8)	10.9	0.28	3.2					
	N43xxEM-L			•	3055 (21.6)	7.0	0.66	7.7					
N43xxEL-L			•	3010 (21.2)	5.7	0.99	11						
N43xxEK-L			•	3070 (21.7)	4.4	1.65	19.6						
Enhanced 3 Stack	K43xxHN-L	•			5700 (40.2)	15.4	0.14	2.5	1.0	0.229 (1.62)	25.7 (11.6)	110 (489)	404 (1800)
	K43xxLN-L		•			7.7	0.55	10					
	K43xxHM-L	•			5630 (39.7)	9.9	0.33	5.9					
	K43xxLM-L		•			4.9	1.32	23.7					
	K43xxHL-L	•			5530 (39.0)	8.0	0.50	8.5					
	K43xxLL-L		•			4.0	1.98	34.1					
	K43xxHK-L	•			5655 (39.9)	6.2	0.82	15.2					
	K43xxLK-L		•			3.1	3.29	60.7					
	K43xxEN-L			•	4030 (28.4)	10.9	0.28	2.5					
	K43xxEM-L			•	3985 (28.1)	7.0	0.66	5.9					
	K43xxEL-L			•	3910 (27.6)	5.7	0.99	8.5					
	K43xxEK-L			•	4000 (28.2)	4.4	1.65	15.2					

Notes

N - Motor Series
4 - Frame Size
2 - Stack Length
H - Mounting
R - Construction
L - Lead Connection
G - Winding Type
-
L - Rotor Type
N - Shaft Cfg.
N - Shaft Mod.
-
NS - Encoder Opt.
-
00 - Customization

0.125 inch divisions

K4 / N4 Series Stepper Motors

K4/N4 Performance Curves

N41xxHJ-L w/ P70530

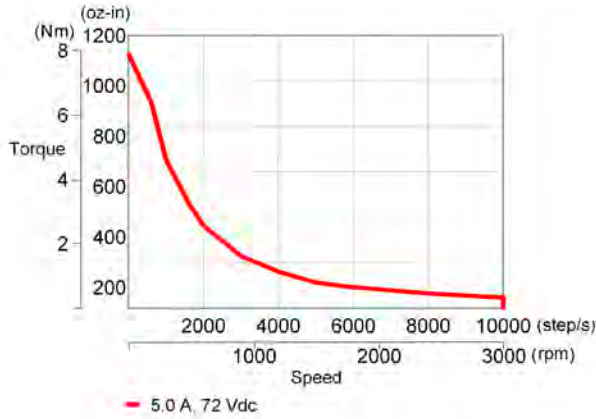

K41xxHJ-L w/ P70530

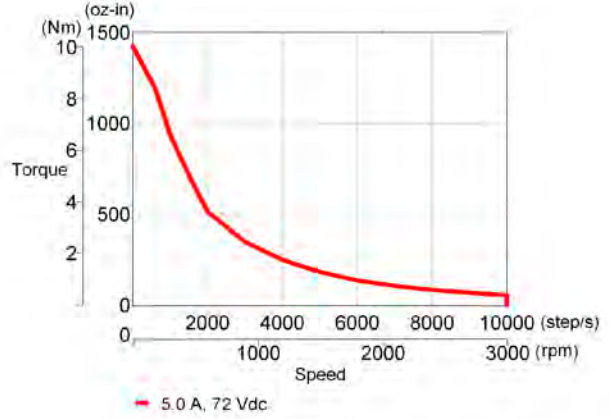

N41xxxF-L w/ P6000

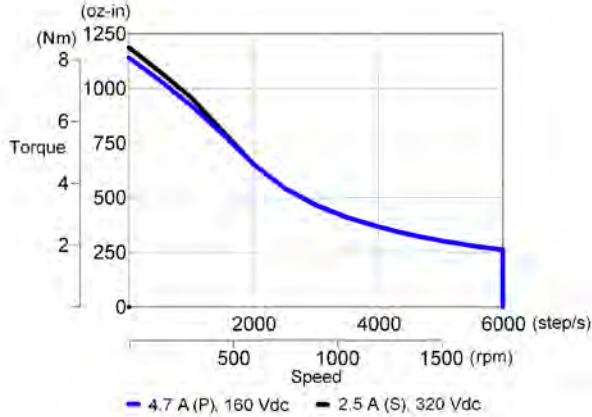

K41xxxF-L w/ P6000

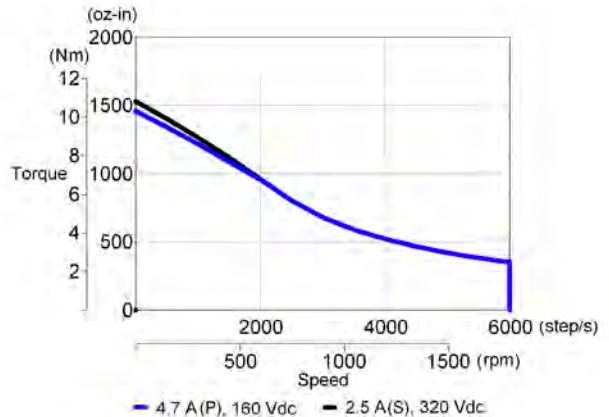

N41xxLG-L w/ P70360

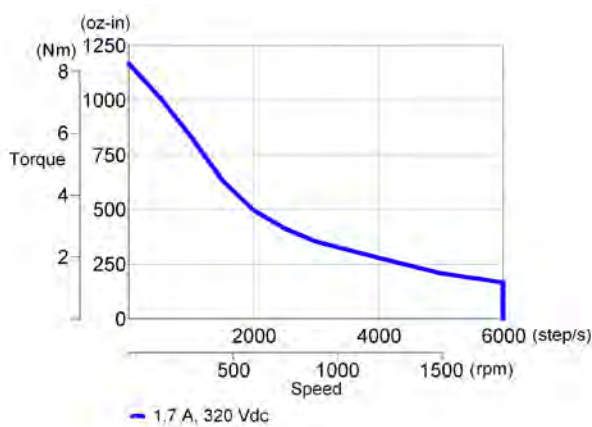

K41xxLG-L w/ P70360

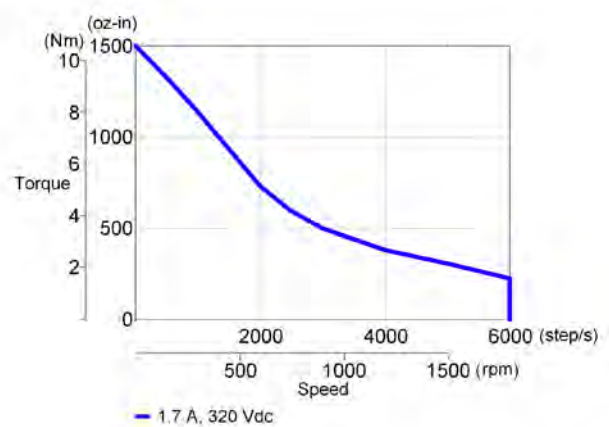

K4/N4 Performance Curves

N42xxF-L w/ P6000

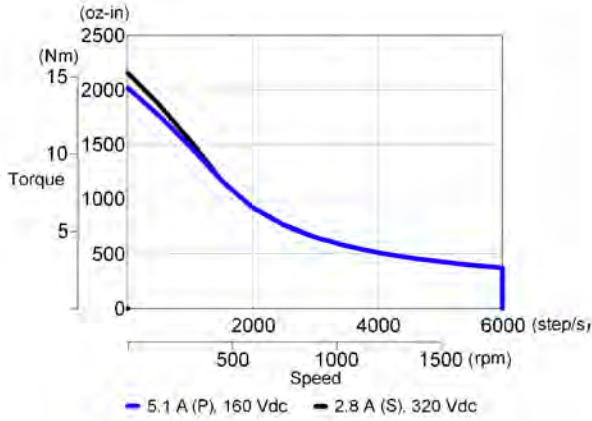

K42xxxF-L w/ P6000

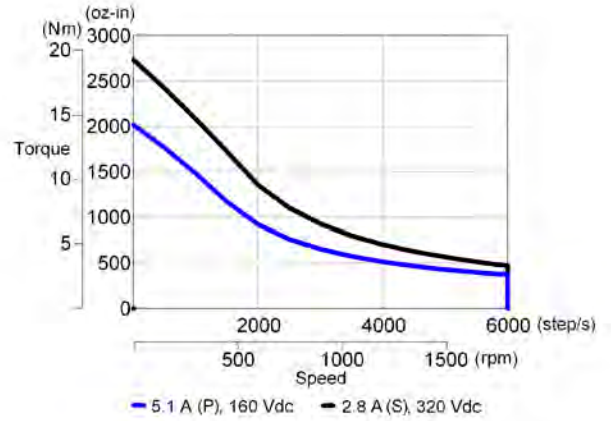

N42xxLG-L w/ P70360

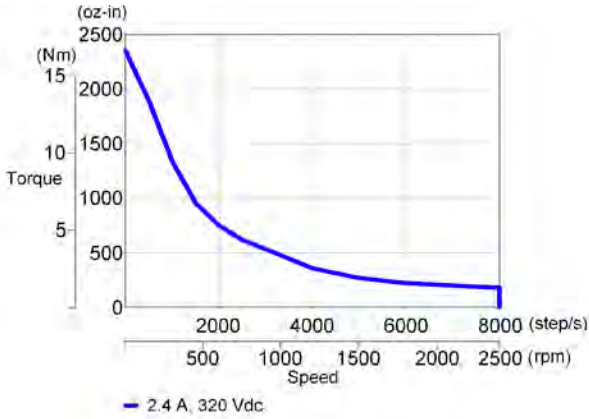

K42xxLG-L w/ P70360

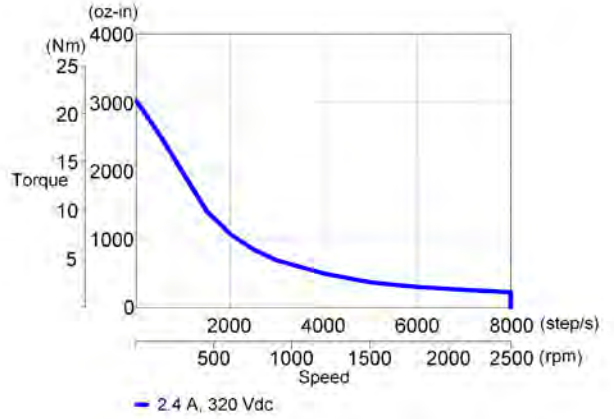

POWERPAC® K/N Series Stepper Motors

K/N Encoder Options

Encoder Specifications

Parameter	Code	
	PD	PF
Type	Optical Incremental	
Supply Voltage	5 Vdc ±10%	
Lines per Revolution	500	1000
Output Format	Dual Channel Quadrature with Index (Z)	
Output Type	Differential Line Drive (with compliments)	
Output Frequency (kHz)	100	
Operating Temperature (°C)	-40 to 100	
Storage Temperature (°C)	-40 to 100	

PD Encoder Dimensional Drawings

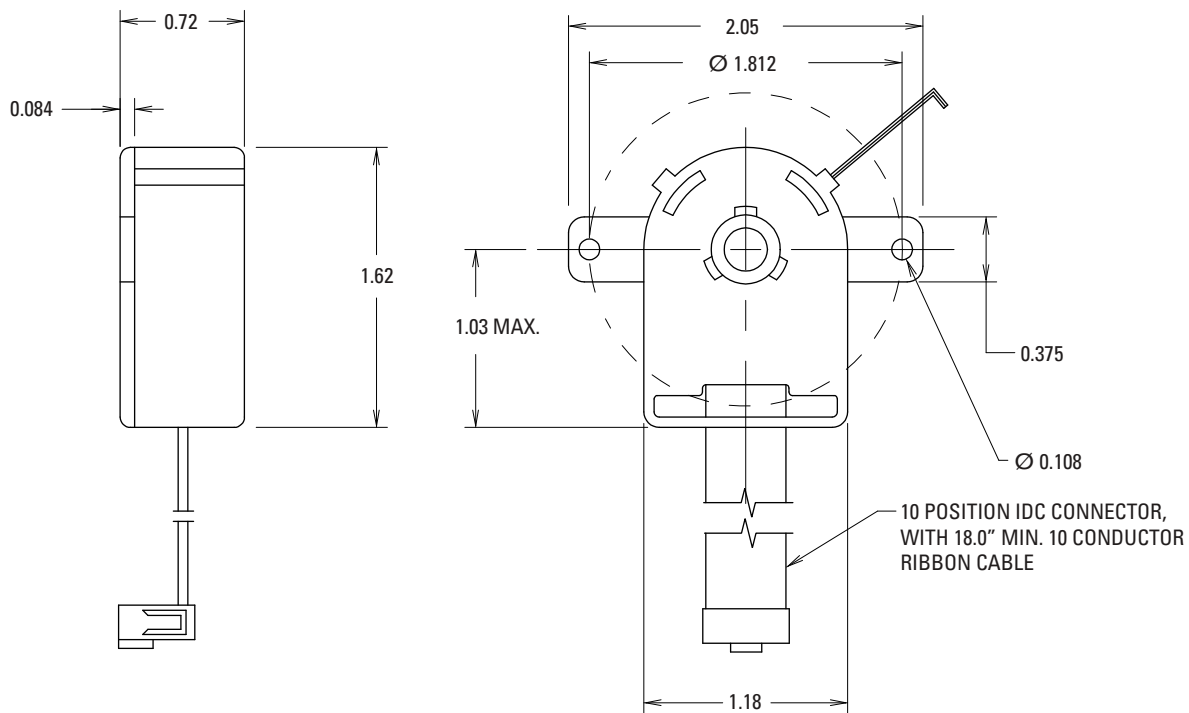

PF Encoder Dimensional Drawings

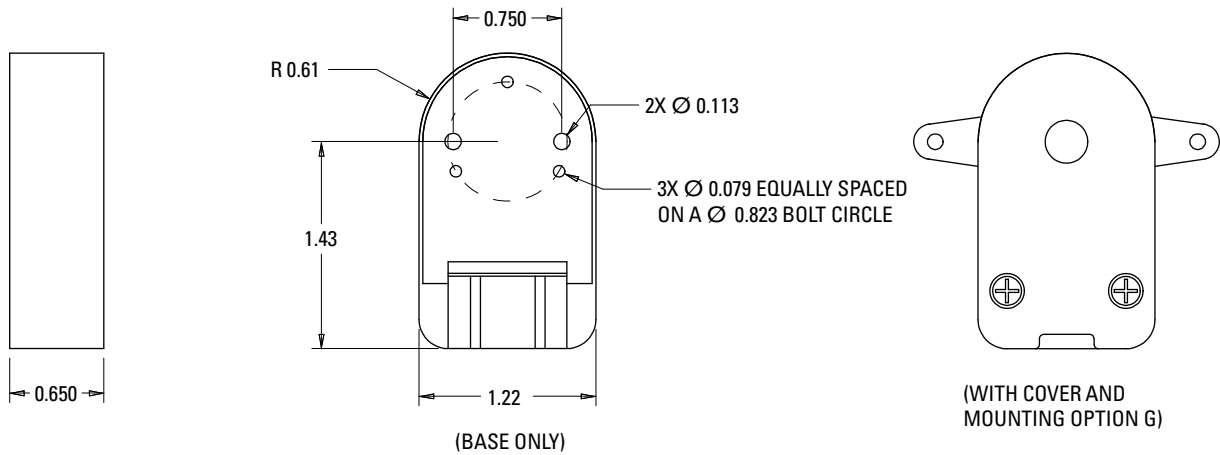

PD, PF Encoder Connection

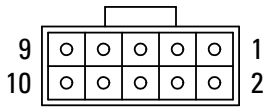

10 -PIN Connector	Color	Function	MS Connector
1	Brown	N/C	-
2	Red	+5 V	G
3	Orange	GROUND	H
4	Yellow	N/C	-
5	Green	\bar{A}	A
6	Blue	A	B
7	Violet	\bar{B}	C
8	Gray	B	D
9	White	Z (Index)	E
10	Black	\bar{Z} (Index)	F

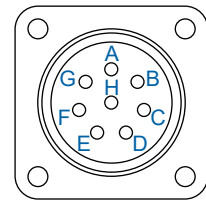

**MS Connector
MS3102E20-7P**

Mating Plug Type
MS3106F20-7S

PD, PF Encoder Phase Diagram

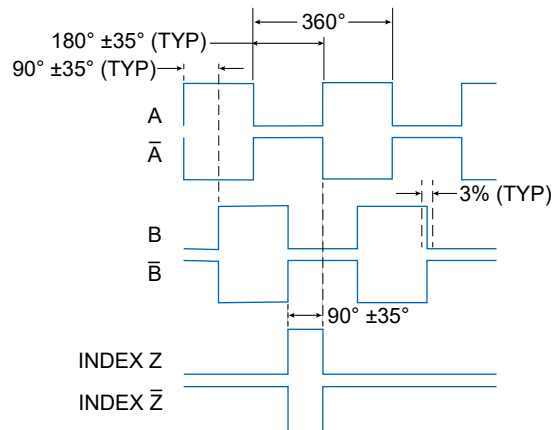

OUTPUT FORMAT FOR CCW ROTATION VIEWED
FROM ENCODER END

More Expertise for a More Successful Machine

Our global engineering, service and support network provides deep knowledge of all the major industries that rely on advanced motion control and automation technology. We offer world-class engineering expertise, self-service design tools, personalized field service, and easy access to our design, application and manufacturing centers in strategic locations across the globe.

About Kollmorgen

Kollmorgen, a Regal Rexnord brand, has more than 100 years of motion experience, proven in the industry's highest-performing, most reliable motors, drives, linear actuators, AGV (Automated Guided Vehicle) control solutions, and automation control platforms. We deliver breakthrough solutions that combine exceptional performance, reliability and ease of use, giving machine builders an irrefutable marketplace advantage.



KOLLMORGEN

A REGAL REXNORD BRAND

www.kollmorgen.com

Specifications are subject to change without notice. It is the responsibility of the product user to determine the suitability of this product for a specific application. All trademarks are the property of their respective owners

© 2024 Kollmorgen Corporation. All rights reserved

KM_SG_00091-KN_RevD_EN